



# Vitec Imaging Solutions for Business

Video & Broadcast

Photo

Cinema



Part of The Vitec Group





# Exceptional Product Performance

## Customer Focus

Vitec Imaging Solutions is the leading global provider of premium branded products and solutions to the rapidly changing and expanding “image capture and content creation” market. Our customers include professional and amateur image makers, independent content creators and vloggers, broadcasters, film studios, photographers, and audio professionals. VIS, manufactures and

distributes premium high-performance products and solutions – including camera supports and heads, camera and equipment bags, smartphone accessories, motion control, lens filters, lighting supports, lighting controls, backgrounds, audio capture and noise reduction equipment marketed under the most recognised brands in the industry.

## Manufacturing Quality & Standards



Vitec Imaging Solutions' products are designed to conform to strict industry standards of quality, performance, and safety, manufactured using only the finest materials and to an extremely high level of precision and tolerance. Many products meet and exceed internationally recognised safety standards such as TÜV, DIN, and CE. These certifications set VIS products apart from other brands on the market and provide customers complete assurance that these products surpass the most rigorous tests for safety, reliability and performance, and are able to withstand repeated use, extreme working conditions, high-stress situations and heavy payloads.



**ISO 9000 - Quality Management**  
Unparalleled quality is Vitec Imaging Solutions' core focus, and essential to the company's mission as industry leader. The ISO 9000 quality management standard family comprises some of ISO's best-known standards, and provides VIS with the necessary framework to continuously improve quality and ensure that customer expectations are always met and often surpassed.



**ISO 14000 - Environmental Management**  
Vitec Imaging Solutions applies this family of standards to successfully manage another essential priority in its operations: environmental responsibility. In complying with ISO 14001, and all other standards in this category, VIS uses tools such as audits, communications, life-cycle analysis, and environmental assessments to ensure that its operations have a minimal environmental impact.



**ISO 45001 - Occupational Health and Safety**  
Vitec Imaging Solutions' employees are the company's greatest single asset. Ensuring their health and safety is critical to the company's success. VIS follows the ISO 45001 standard to ensure safe working environments for all its employees.

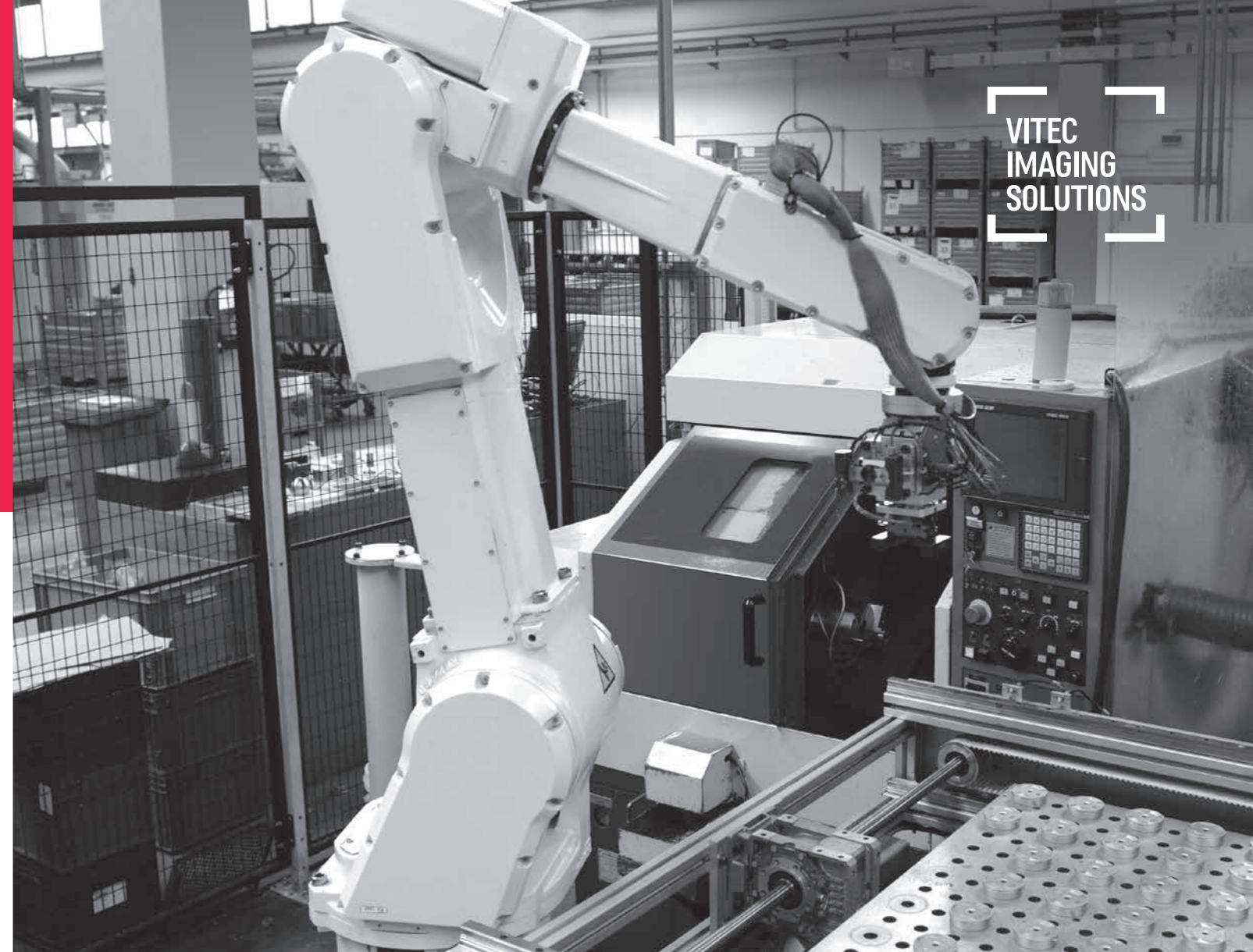

## Top-End R&D Capability

### Patents and Registered Designs

With more than 50 active patents and registered designs across the globe, Vitec Imaging Solutions have a proven track record of designing and building innovative, award-winning products.

### Prototyping and Pioneering Lab

A prototyping work centre to support product development and a Pioneering Lab to create fully working products, small production batches, and limited-edition models.

### Mould Design and Production

Full design capabilities to design and manufacture complex moulds for technical components to be produced using specified polymers or metal alloys.

### 3D CAD/CAM and FEM Simulator

Computer-aided design and computer-aided manufacturing including FEM simulator to reduce the number of physical prototypes and experiments and optimise components in their design phase to develop better products, faster.

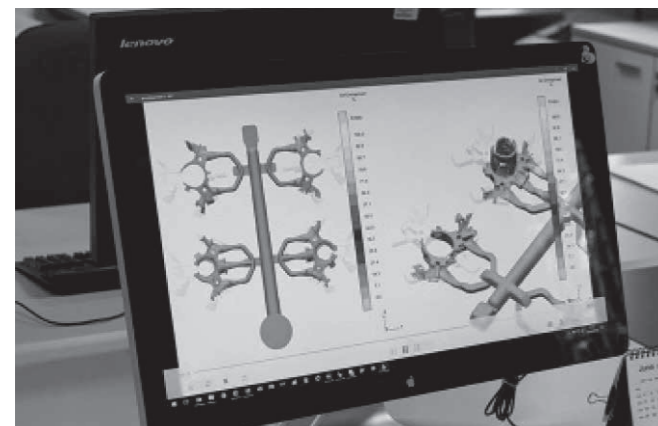

### 3D Printing

3D printing to produce functional and visual prototypes in different materials and colours.

### Climatic and Salt Spray Testing

A closed cabinet or chamber used to simulate extreme climatic and environmental conditions. This accelerated and controlled process tests the resistance of materials and surface coatings to ensure that they are able to perform in the conditions they are designed for.

### Mechanical and Lifetime Simulation Testing

A range of machines designed to test a product or component by subjecting it to a specific set of conditions including stress, strain, temperature – in excess of its normal service parameters in an effort to uncover faults and potential modes of mechanical failure.

### Audio Testing

An in-house semi-anechoic chamber, built to high specifications, incorporating special test equipment to capture a number of acoustic measurements including acoustic transparency, wind and shock protection efficiency, and polar response. The chamber also incorporates a fully controllable, and acoustically isolated wind tunnel to measure the impact of wind when recording sound.

## Manufacturing Processes

### Industry 4.0

The company's manufacturing systems are seamlessly integrated with its IT systems. This enables us to monitor performance in real time via dashboards located throughout the factory. Efficiency, downtime events, and production progress are tracked for each order. Knowing precisely when an order will be completed allows us to keep changeover and setup times to a minimum. Moreover, the integrated machinery allows VIS to track and analyse comprehensive quality metrics for continuous production process improvement. In parallel, the machinery itself is monitored to optimise preventative maintenance.

### Aluminium, Carbon, and Steel Tube Machining

Highly automated and semi-automated processing lines working with aluminium, carbon and steel tubular profiles. Processes include cutting, drilling, deforming, and cleaning.

### Multi-Axis CNC Machining

Multiple axis CNC milling machines providing high precision mechanical machining of aluminium and magnesium parts.

### Lathe Machining

Multiple lathe machines offering precision mechanical machining of aluminium alloys.

### Welding and Bending

Welding processes to create strong, permanent joins between metal components for added strength, durability, and longevity.

### Powder-Coating Paint Tunnel

Fully automated large-scale powder-coating spray tunnel and manual painting workstation for aluminium, steel and magnesium components.

# Leading Brands

The Vitec portfolio offers the widest choice of leading brands on the market.

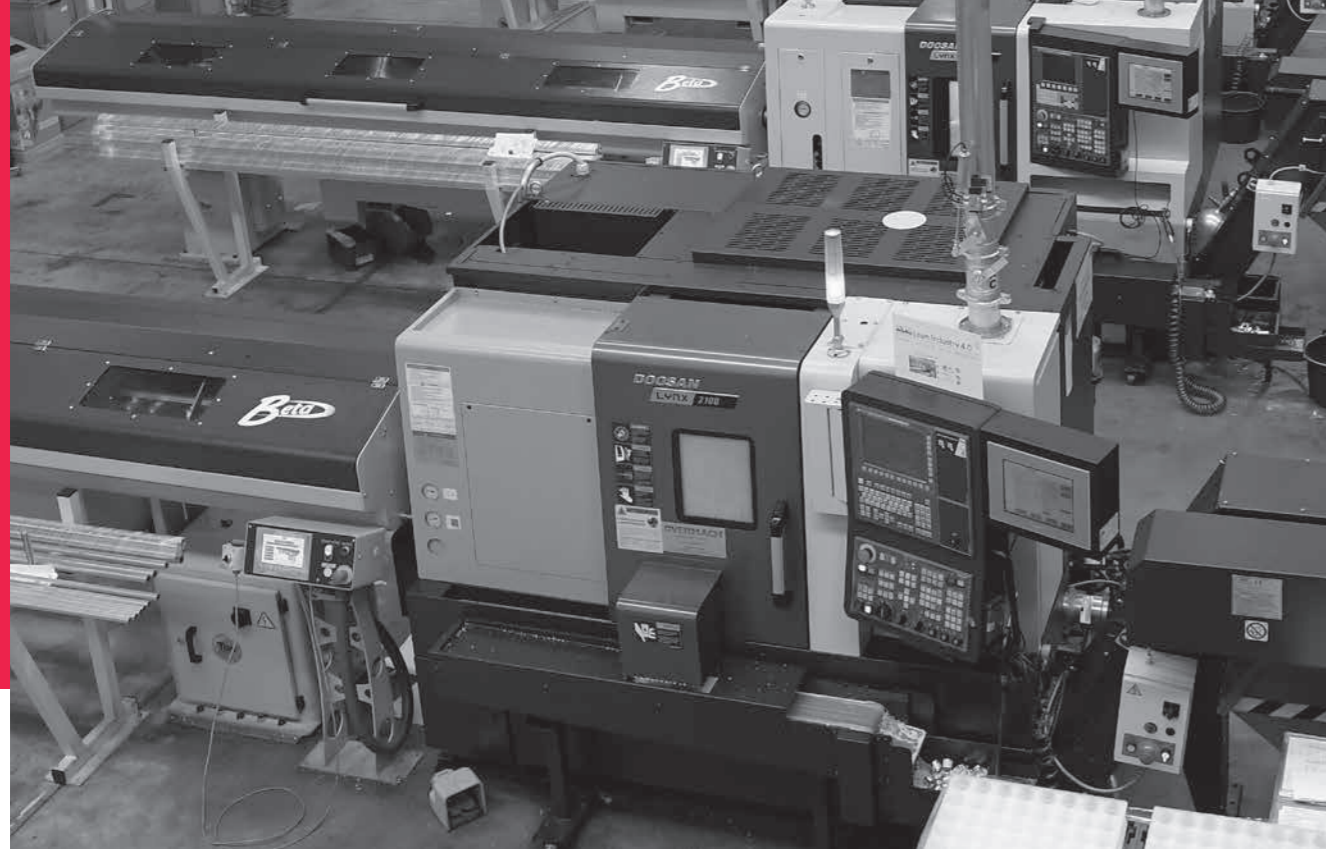

## Laser Engraving

Highly detailed laser engraving for branding components with complex logos and designs, or for permanently marking surfaces with important information such as product specifications or safety instructions and certifications. Ideal for individual personalisation or bespoke products.

## Graphic Sublimation on Aluminium Tubing

A process used to apply complex graphical full colour designs to three-dimensional aluminium tubular components where traditional printing methods would not work. Great for bespoke, personalised or limited production runs.

## Textile Cutting and Sewing

Automated textile cutting using digitised patterns and efficient tiling configurations. Semi-automated and manual sewing machines to perform specific tasks and sewing techniques, depending on the materials being joined together.

## Lean and Modular Assembly Lines

Optional assembly lines to adapt to the complexity of the product assembly, batch volumes, and time efficiencies.



Manfrotto designs, manufactures and markets a wide range of innovative camera accessories and lighting solutions including tripods, lighting stands, bags, and gimbal stabilisers.



Lastolite by Manfrotto is the world's leading manufacturer of backgrounds and lighting control systems for the photo, video and cinema industry.



Avenger offers a range of stands, lighting controls, system components and accessories for photo and video productions. Avenger products are robust, safe and steady.



Syrp designs and develops motorised camera sliders, motion control hardware and software, which enables ICCs to control their camera equipment remotely – allowing the capture and smooth tracking of shots for video, time-lapse and hyper-lapse photography.



Rycote is a highly respected, market-leading audio brand, trusted by creative professionals, and a manufacturer of advanced noise reduction equipment for the audio capture market.



JOBY creates innovative, revolutionary products for today's dynamic content creator. In 2006, JOBY introduced the patented GorillaPod which has transformed the imaging accessories market. This award-winning product redefined how creators mount their cameras, lights or mobile technology – allowing them to connect in new ways and embrace today's new platforms.



For over a century, professionals all over the world have acknowledged Gitzo tripods, monopods, heads and accessories as the industry standard in excellence.



Lowepro specialises in backpacks, cases and camera bags for the adventure market and has been an essential part of countless adventures through every climate and condition over the last 50 years.

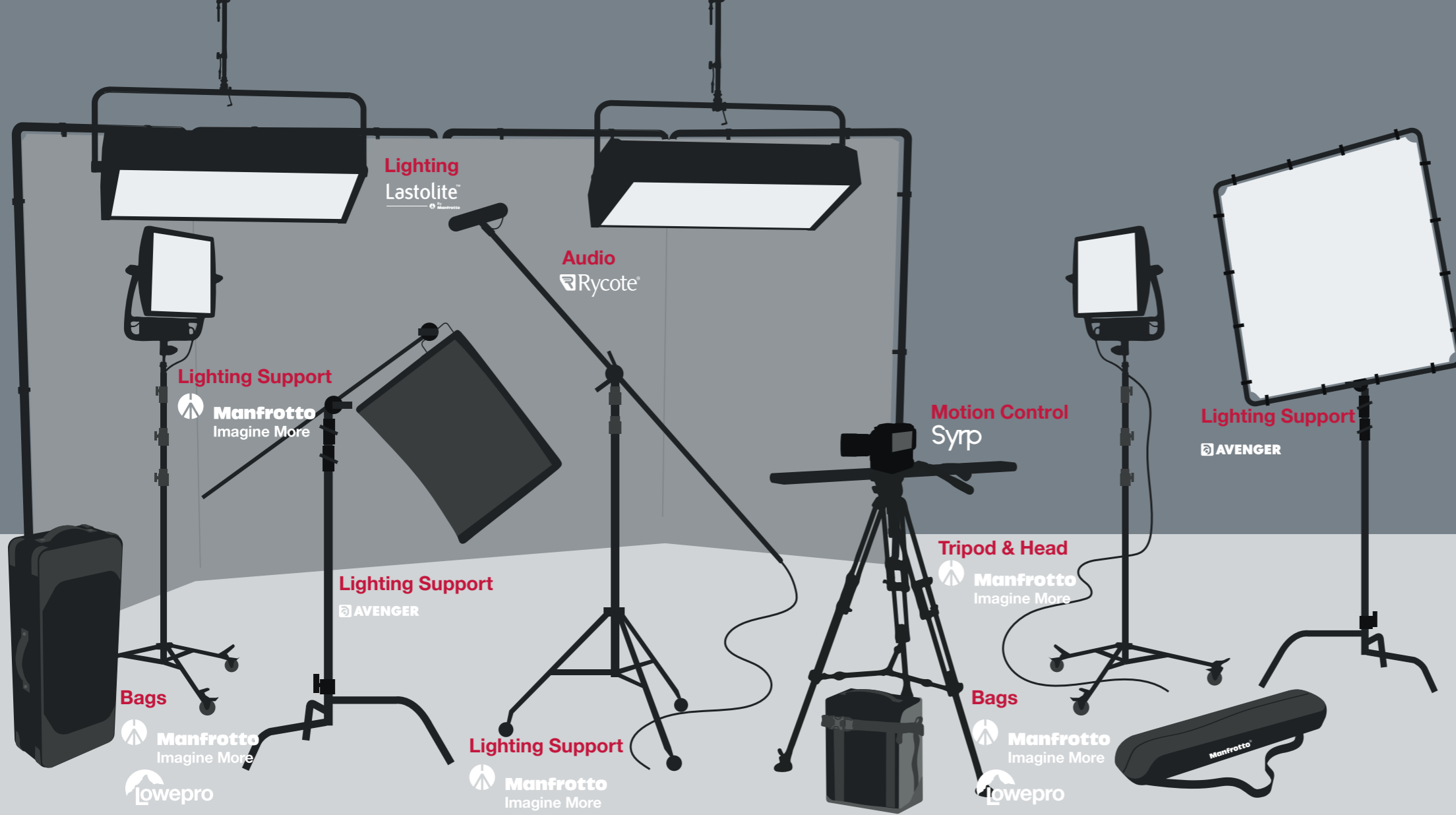

# video & broadcast

Vitec Imaging Solutions is a leading global provider of highly respected products and solutions designed and manufactured to meet the needs of the rapidly-changing and exceptionally demanding video and broadcast markets.

Our brands are among the most recognised in the industry, offering an extensive portfolio of high-performance products. These include the full spectrum of essential equipment required to capture professional moving image content – such as camera supports and heads, motion control, camera and equipment bags, stands, brackets and support arms, lighting control, backgrounds, audio capture accessories, and noise reduction equipment.



# photo

Vitec Imaging Solutions designs, manufactures, and distributes a comprehensive range of premium branded photographic equipment for exacting professional and amateur photographers.

Our brands are instantly identified by an ever-increasing community of photographers who seek to keep pushing the boundaries of their creativity. Our innovators provide image creators with the key high-performance products at the core of capturing professional still images – including camera supports and heads, filters, camera and equipment bags, stands, brackets, support arms, lighting control, and backgrounds.



# cinema

Vitec Imaging Solutions is a global market leader in the production of high-end gear and solutions that flawlessly meet the demands of the constantly evolving cinema market.

Our brands are among the most acclaimed in their field and cater for the highly-specialised requirements of cinema capture professionals with essential elements – encompassing camera supports and heads, camera and equipment bags, motion control, stands, brackets, and support arms, lighting controls, backgrounds, audio capture and noise reduction equipment.





**Manfrotto**  
Imagine More

Manfrotto has long been recognised as the industry leader in the design, innovation, and production of photography and videography products for the discerning professional. Tripods, monopods, heads, gimbals, stabilisers, and lighting solutions form the core of an almost endless list of peerless equipment that professionals have come to depend on for almost half a century. Lino Manfrotto established the company in 1972 based on his long experience in the field – with a mission to support and simplify the work of reporters, photographers, and cinematographers. Ever since, the brand has remained one step ahead with market-leading innovation and design, benchmark quality, and the extreme reliability that have become synonymous with the name Manfrotto and its instantly recognisable iconic logo.

Precision and reliability, in tandem with the aesthetic and functional elegance of high-end products that are entirely conceived, designed and manufactured in Italy, are at the very core of a unique style that reflects Manfrotto's fundamental ethos. The brand's insistence on maintaining 100% Italian manufacture and quality control testifies to the company's commitment to guaranteeing industry-standard product functionality and durability over time. At the heart of the company is a multidisciplinary team of highly dedicated and experienced professionals – constantly driving a relentless process of innovation and progressive technological goals.

Manfrotto consistently receives numerous industry awards every year – proof positive that their insistence on premium design, functionality, and technology continues to confirm their products as the universally recognised standard of excellence in the world of photographic accessories.

## Products:

- |                     |                        |
|---------------------|------------------------|
| Video heads         | Lighting stands        |
| Video tripods       | Autopole               |
| Video accessories   | Clamps                 |
| Video monopods      | Arms                   |
| Gimbal              | Scrim                  |
| Video accessories   | Chroma Key             |
| Photo tripods       | Pro Light Reloader bag |
| Photo heads         | Pro Light bag          |
| 360 Virtual Reality | Rolling Organisers bag |
| Photo accessories   | Lino bag               |





# Video Heads

Manfrotto Video Heads are the fruit of expertise, quality and continuous innovation, which make these products reliable companions for all videographers looking for a tool that will give them full control of their camera. A video head is of paramount importance: it is the one component that really gives you control over your DSLR or camcorder, so it's worth choosing yours very carefully indeed if you need heads for video use. Video heads are also popular among wildlife photographers, sports optics users and sports

photographers who use long telephoto lenses, as they help balance your camera with the sliding plate, and stabilize your equipment with a counterbalance system. A video head should be the first piece of gear to be selected if the factors that determine your choice of video support system are versatility, application-specific design, speed in use, or precision. Once you have found the ideal head, you can look for the perfect video tripod or video monopod to match it, and create your perfect kit.

|   | 612   | 608   | 526                 | 509HD  | 504X  | MVH502AH                                    | MVH500AH                                    |
|---|---|---|---------------------|--|---|---|---|
| <b>VIDEO HEAD</b>                       |   |   |                     |  |   |   |   |
| <b>FDS</b><br>Fluidity<br>PAN&TILT      | Variable                                    | Variable                                    | Variable            | Variable   | Variable                                    | Variable                                    | Fixed                                       |
| <b>CBS</b><br>Counter<br>Balance System | Variable<br>continuous                      | Variable<br>continuous                      | Variable            | Variable   | Variable steps                              | Fixed                                       | Fixed                                       |
| <b>FLAT</b><br>Flat base                | Flat base with<br>3/8" female<br>attachment | Flat base with<br>3/8" female<br>attachment | -                   | -  | Flat base with<br>3/8" female<br>attachment | Flat base with<br>3/8" female<br>attachment | Flat base with<br>3/8" female<br>attachment |
| <b>Leveling bowl</b>                    | -   | -   | 100                 | 100  | -   | -   | -   |
| <b>Counter<br/>balance weight</b>       | 4-12kg<br>8.8-26.4lb                        | 0-8kg<br>0-17.6lb                           | 8-15kg<br>17.6-33lb | 12.8kg-28.1lb<br>@ 55 C.O.G.)<br>8.5kg-18.7lb<br>@ 125 C.O.G.) | 6.5kg<br>14.3lb                             | 4kg<br>8.8lb                                | 2.4kg<br>5.3lb                              |
| <b>max</b><br>Safety payload            | 12kg<br>26.4lb                              | 8kg<br>17.6lb                               | 16kg<br>35.3lb      | 13.5kg-29.8lb<br>@ 55 C.O.G.)<br>9kg-19.8lb<br>@ 125 C.O.G.)   | 12kg<br>26.5lb                              | 7kg<br>15.4lb                               | 5kg<br>11lb                                 |
| <b>C.O.G</b><br>Center of gravity       | 55  | 55  | 125                 | 55<br>125  | 55  | -   | -   |
| <b>Head height</b>                      | 15cm<br>5.9in                               | 15cm<br>5.9in                               | 15cm<br>5.9in       | 17.8cm<br>6.9in  | 14.9cm<br>5.8in                             | 13cm<br>5.1in                               | 9.5cm<br>3.7in                              |
| <b>Weight</b>                           | 2.27kg<br>5lb                               | 2.22kg<br>4.9lb                             | 3.6kg<br>7.9lb      | 3.8kg<br>8.4lb   | 2kg<br>4.4lb                                | 1.7kg<br>3.7lb                              | 0.9kg<br>2.1lb                              |
| <b>Sliding plate</b>                    | 504PLONGRL                                  | 504PLONGR-1                                 | 357PLV              | 509PLONG   | 504PLONGR-1                                 | 504PLONG                                    | 500PLONG                                    |



# Counterbalance System

Counterbalance System (CBS) is a fundamental part of what makes video heads such useful tools. The principal function of the CBS is to cancel out the slow falling effect seen in video footage when the camera's own weight causes it to tilt forward or backward on an unbalanced video head. It ensures that the cameramen need only to apply minimal effort to the head's pan bar to move the camera precisely and smoothly. Please keep in mind that each head has a maximum counterbalance weight that depends on a specific Center of gravity value. But what is The Center of Gravity? it is an imaginary point where the weight of the gear is concentrated that is measured starting from the top of the sliding plate. Manfrotto video heads consider a 55mm COG as a standard. Center of gravity drives the

counterbalance weight value: this means that you have to pay attention on your set up. If your camera configuration has COG higher than the standard (55mm) even if the weight is within the Counter balance weight range the head won't work properly! CBS comes in three variations: Fixed, Step, and Continuous. While fixed CBS is set to a specific weight, the Step Counterbalance system offers a few different weight options, allowing for more flexibility in using different cameras. Continuous CBS on the other allows to continuously keep your gears counterbalanced with many type of configuration throughout the entire tilt range. In this case you don't have steps, this means you have the freedom to set up your camera in many different ways without worrying to loose performance.





# Nitrotech 612 Fluid Video Head



- variable
- variable continuous
- 55 C.O.G.
- FLAT

## MVH612AH NITROTECH 612 FLUID VIDEO HEAD

The NITROTECH 612 Manfrotto fluid video head is provided with the innovative Nitrogen piston mechanism which allows continuous counterbalance. NITROTECH 612 ensures a high control of a camera with accessories from 4 to 12kg (8.8-26.4 lbs). Extremely smooth movement is guaranteed by the fluidity function on both pan and tilt. The camera can be attached easily, safely and quickly to the 180mm sliding plate and secured to the head with a side-lock mechanism. External monitors and accessories can be securely mounted on the head thanks to a 3/8" Easy Link equipped with an anti-rotation mechanism. The NITROTECH 612 has a flat base mount with a standard 3/8" thread that is highly versatile for different support combinations (tripod, slider, jib or crane).

- 4-12kg 8.8-26.4lb
- 12kg 26.4lb
- 15cm 5.9in
- 2,27kg 5lb
- 504PLONGRL

- 1 Pan drag control
- 2 Pan locking knob
- 3 Illuminated leveling bubble



- 1 Counterbalance adjustment knob
- 2 Tilt drag knob
- 3 Tilt locking knob
- 4 Easy Link - 3/8" thread connection with anti-rotation



- 1 Nitrogen piston
- 2 Side lock lever
- 3 Sliding quick release plate



### COUNTERBALANCE GRAPH

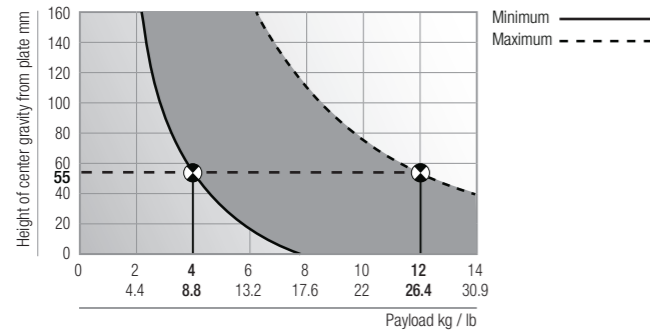

### TECHNICAL SPECIFICATIONS

|                              |   |                                    |   |
|------------------------------|---|------------------------------------|---|
| <b>Head base</b>             | Flat  | <b>Pan bar attachment</b>          | Available on right and left sides               |
| <b>Pan drag type</b>         | Fixed cartridge (continuously adjustable from 0 to max level) | <b>Replaceable pan bar rosette</b> | Yes   |
| <b>Tilt drag type</b>        | Fixed cartridge (continuously adjustable from 0 to max level) | <b>Plate type</b>                  | 504PLONGRL Quick Release with side lock         |
| <b>Counterbalance system</b> | Variable continuous   | <b>Plate travel</b>                | 140mm (5.51in)                                  |
| <b>Counterbalance weight</b> | 4 - 12kg (8.8 - 26.4lb)                                       | <b>Plate attachment</b>            | 3/8" and 1/4" camera screws + anti-rotation pin |
| <b>Safety payload</b>        | 12kg (26.4lb)   | <b>Pan range</b>                   | 360°  |
| <b>Leveling bubble</b>       | Available (illuminated with led)                              | <b>Tilt range</b>                  | -70° +90°                                       |
| <b>Pan bar</b>               | Available   | <b>Temperature range</b>           | -15° C +50° C                                   |



# Nitrotech 612 Fluid Video Head Kit



## MVK612TWINMC KIT

- 4-12kg 8.8-26.4lb
- 12kg 26.4lb
- 86cm 33.9in
- 75cm 29.5in
- 169cm 66.5in
- 5,74kg 12,7lb

**Head Tripod Bag** MVH612AH Carbon Fiber MVTTWINMC included



## MVK612TWINGC KIT

- 4-12kg 8.8-26.4lb
- 12kg 26.4lb
- 85cm 33.5in
- 49cm 19.3in
- 176cm 69.3in
- 6,01kg 13.2lb

**Head Tripod Bag** MVH612AH Carbon Fiber MVTTWINGCUS included



## MVK612CTALL KIT

- 4-12kg 8.8-26.4lb
- 12kg 26.4lb
- 87cm 34.3in
- 42cm 16.5in
- 218cm 85.8in
- 6,27kg 13.8lb

**Head Tripod Bag** MVH612AH Carbon Fiber 536 included



## MVK612TWINMA KIT

- 4-12kg 8.8-26.4lb
- 12kg 26.4lb
- 86cm 33.9in
- 75cm 29.5in
- 169cm 66.5in
- 6,04kg 13,3lb

**Head Tripod Bag** MVH612AH Aluminium MVTTWINMA included



## MVK612TWINGA KIT

- 4-12kg 8.8-26.4lb
- 12kg 26.4lb
- 85cm 33.5in
- 49cm 19.3in
- 176cm 69.3in
- 6,29kg 13.9lb

**Head Tripod Bag** MVH612AHU Aluminium MVTTWINGA included



## MVK612TWINFC KIT

- 4-12kg 8.8-26.4lb
- 12kg 26.5lb
- 89,5cm 35.2in
- 43,5cm 17.1in
- 173cm 68.1in
- 5,9kg 13lb

**Head Tripod Bag** MVH612AH Carbon Fiber MVTTWINFC included



## MVK612TWINFA KIT

- 4-12kg 8.8-26.4lb
- 12kg 26.5lb
- 89,5cm 35.2in
- 43,5cm 17.1in
- 173cm 68.1in
- 6,2kg 13.6lb

**Head Tripod Bag** MVH612AH Aluminium MVTTWINFA included



## MVK612SNGFC KIT

- 4-12kg 8.8-26.4lb
- 12kg 26.5lb
- 89,5cm 35.2in
- 44,5cm 17.5in
- 171cm 67.3in
- 5,6kg 12.3lb

**Head Tripod Bag** MVH612AH Carbon Fiber MVTSNGFC included



# Nitrotech 608 Fluid Video Head



- variable
- variable continuous
- 55 C.O.G.
- FLAT

## MVH608AH NITROTECH 608 FLUID VIDEO HEAD

The NITROTECH 608 fluid video head features state-of-the-art technology consisting in a Nitrogen piston mechanism that allows continuous counterbalance system that enables precise control of a camera and accessories up to 8kg (17.6lb). The variable fluidity function on both pan and tilt allows smooth, judder-free movement. It also features a 3/8" Easy Link equipped with an anti-rotation function that enables an external monitor or other accessories to be fitted. The sliding plate attachment side-lock mechanism allows safe, quick and easy camera attachment. The NITROTECH 608 head has a flat base mount with a standard 3/8" thread that is highly versatile for different support combinations (tripod, slider, rig or crane).

- 0-8kg / 0-17.6lb
- 8kg / 17.6lb
- 15cm / 5.9in
- 2,22kg / 4.9lb
- 504PLONGR-1

- 1 Pan drag control
- 2 Pan locking knob
- 3 Illuminated leveling bubble



- 1 Counterbalance adjustment knob
- 2 Tilt drag knob
- 3 Tilt locking knob
- 4 Easy Link - 3/8" thread connection with anti-rotation



- 1 Nitrogen piston
- 2 Side lock lever
- 3 Sliding quick release plate

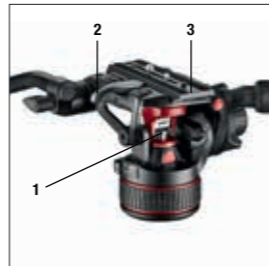

COUNTERBALANCE GRAPH

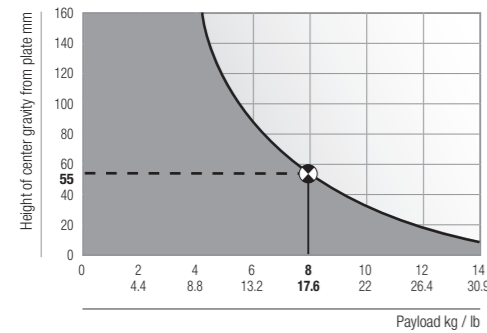

### TECHNICAL SPECIFICATIONS

|                              |   |                                    |   |
|------------------------------|---|------------------------------------|---|
| <b>Head base</b>             | Flat  | <b>Pan bar attachment</b>          | Available on right and left sides               |
| <b>Pan drag type</b>         | Fixed fluid cartridge (continuously adjustable from 0 to max level) | <b>Replaceable pan bar rosette</b> | Yes   |
| <b>Tilt drag type</b>        | Fixed fluid cartridge (continuously adjustable from 0 to max level) | <b>Plate type</b>                  | 504PLONGR-1 Quick Release with side lock        |
| <b>Counterbalance system</b> | Variable continuous   | <b>Plate travel</b>                | 90mm (3.54in)                                   |
| <b>Counterbalance weight</b> | 0 - 8kg (0 - 17.6lb)  | <b>Plate attachment</b>            | 3/8" and 1/4" camera screws + anti-rotation pin |
| <b>Safety payload</b>        | 8kg (17.6lb)  | <b>Pan range</b>                   | 360°  |
| <b>Leveling bubble</b>       | Available (illuminated with led)                                    | <b>Tilt range</b>                  | -70° +90°                                       |
| <b>Pan bar</b>               | Available   | <b>Temperature range</b>           | -15° C +50° C                                   |



# Nitrotech 608 Fluid Video Head Kit



## MVK608TWINMC KIT

- 0-8kg / 0-17.6lb
- 8kg / 17.6lb
- 86cm / 33.9in
- 75cm / 29.5in
- 169cm / 66.5in
- 5,47kg / 12.1lb

**Head** MVH608AH  
**Tripod** Carbon Fiber MVTTWINMC  
**Bag** included



## MVK608TWINGC KIT

- 0-8kg / 0-17.6lb
- 8kg / 17.6lb
- 85cm / 33.5in
- 49cm / 19.3in
- 175cm / 68.9in
- 5,74kg / 12.7lb

**Head** MVH608AH  
**Tripod** Carbon Fiber MVTTWINGC  
**Bag** included



## MVK608CTALL KIT

- 0-8kg / 0-17.6lb
- 8kg / 17.6lb
- 87cm / 34.3in
- 42cm / 16.5in
- 218cm / 85.8in
- 6,06kg / 13.4lb

**Head** MVH608AH  
**Tripod** Carbon Fiber 536  
**Bag** included



## MVK608TWINMA KIT

- 0-8kg / 0-17.6lb
- 8kg / 17.6lb
- 86cm / 33.9in
- 75cm / 29.5in
- 169cm / 66.5in
- 5,77kg / 12.7lb

**Head** MVH608AH  
**Tripod** Aluminium MVTTWINMA  
**Bag** included



## MVK608TWINGA KIT

- 0-8kg / 0-17.6lb
- 8kg / 17.6lb
- 85cm / 33.5in
- 49cm / 19.3in
- 175cm / 68.9in
- 6,02kg / 13.3lb

**Head** MVH608AH  
**Tripod** Aluminium MVTTWINGA  
**Bag** included



## MVK608TWINFC KIT

- 8kg / 17.6lb
- 8kg / 17.6lb
- 89,5cm / 35.2in
- 43,5cm / 17.1in
- 173cm / 68.1in
- 5,8kg / 12.8lb

**Head** MVH608AH  
**Tripod** Carbon Fiber MVTTWINFC  
**Bag** included



## MVK608TWINFA KIT

- 8kg / 17.6lb
- 8kg / 17.6lb
- 89,5cm / 35.2in
- 43,5cm / 17.1in
- 173cm / 68.1in
- 6,1kg / 13.4lb

**Head** MVH608AH  
**Tripod** Aluminium MVTTWINFA  
**Bag** included



## MVK608SNGFC KIT

- 8kg / 17.6lb
- 8kg / 17.6lb
- 89,5cm / 35.2in
- 44,5cm / 17.5in
- 171cm / 67.3in
- 5,6kg / 12.4lb

**Head** MVH608AH  
**Tripod** Carbon Fiber MVTSNGFC  
**Bag** included



# 526 Pro Fluid Video Head



- variable
- variable
- 125 C.O.G.
- 100

- 1 Pan locking knob
- 2 Pan drag control
- 3 Leveling bubble



- 1 Tilt locking knob
- 2 Tilt drag knob
- 3 Counterbalance adjustment knob



- 1 Sliding plate safety release button
- 2 Sliding quick release plate
- 3 Sliding quick release knob
- 4 Interchangeable pan bar rosette



## 526-1 PRO FLUID VIDEO HEAD 100MM HALF BALL

The 526-1 Professional Fluid Video Head directly addresses the high-end, heavy-duty video market by offering a feature-packed fluid video head with the ability to support up to 16 kg and counterbalance weight from 8 to 15 kg. It provides a fluid drag system comprised of three step settings for low, medium and high drag levels (numbered 1, 2 and 3), plus an additional no-drag setting (number 0) for occasions such as snap-pans/tilts. It features a continuous counterbalance system for weights between 8 to 15 kg @ 125 mm C.O.G. The built-in 100mm half-ball adapts to a number of our tripods, allowing quick camera levelling with the aid of the leveling bubble.

- 8-15kg / 17.6-33lb
- 16kg / 35.3lb
- 15cm / 5.9in
- 3,6kg / 7.9lb
- 357PLV

### COUNTERBALANCE GRAPH

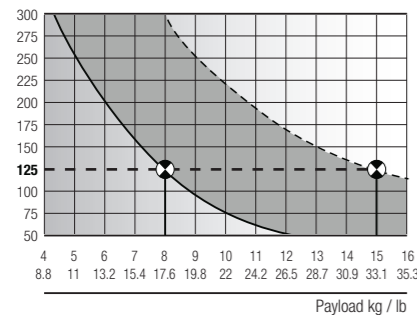

### TECHNICAL SPECIFICATIONS

|                              |                          |                                    |   |
|------------------------------|--------------------------|------------------------------------|---|
| <b>Head base</b>             | 100mm half ball          | <b>Pan bar attachment</b>          | Available on right and left sides               |
| <b>Pan drag type</b>         | 0 plus - 3 steps         | <b>Replaceable pan bar rosette</b> | Yes, on both sides                              |
| <b>Tilt drag type</b>        | 0 plus - 3 steps         | <b>Plate type</b>                  | 357PLV  |
| <b>Counterbalance system</b> | Variable continuous      | <b>Plate travel</b>                | 80mm (3.1in)                                    |
| <b>Counterbalance weight</b> | 8 - 15kg (17.6 - 33.1lb) | <b>Plate attachment</b>            | 3/8" and 1/4" camera screws + anti-rotation pin |
| <b>Safety payload</b>        | 16kg (35.3lb)            | <b>Pan range</b>                   | 360°  |
| <b>Leveling bubble</b>       | Available                | <b>Tilt range</b>                  | -70° +75°                                       |
| <b>Pan bar</b>               | Available (telescopic)   | <b>Temperature range</b>           | -20° C +60° C                                   |



# 526 Pro Fluid Video Head Kit



## 526, 536K-1 KIT

- 8-15kg / 17.6-33lb
- 16kg / 35.3lb
- 86cm / 33.8in
- 43cm / 16.9in
- 218cm / 85.8in
- 7kg / 15.4lb

|               |                  |
|---------------|------------------|
| <b>Head</b>   | 526              |
| <b>Tripod</b> | Carbon Fiber 536 |
| <b>Bag</b>    | included         |

FAST TRIPODS



## MVK526TWINFC KIT

- 8-15kg / 17.6-33lb
- 16kg / 35.3lb
- 88,5cm / 34.8in
- 42,5cm / 16.7in
- 171,5cm / 67.3in
- 7,2kg / 15.8lb

|               |                        |
|---------------|------------------------|
| <b>Head</b>   | 526                    |
| <b>Tripod</b> | Carbon Fiber MVTTWINFC |
| <b>Bag</b>    | included               |

FAST TRIPODS



## MVK526TWINFA KIT

- 8-15kg / 17.6-33lb
- 16kg / 35.3lb
- 88,5cm / 34.8in
- 42,5cm / 16.7in
- 171,5cm / 67.3in
- 7,5kg / 16.5lb

|               |                     |
|---------------|---------------------|
| <b>Head</b>   | 526                 |
| <b>Tripod</b> | Aluminium MVTTWINFA |
| <b>Bag</b>    | included            |



# 509HD Pro Fluid Video Head



- variable
- variable
- 55 C.O.G.
- 125 C.O.G.
- 100

## 509HD PRO FLUID VIDEO HEAD 100MM HALF BALL

The 509HD fluid head combines ergonomic design features with professional performance. To help you obtain incredibly smooth camera movements and great footage, the 509HD has variable fluid drag and a fast, precise, 4-step counterbalance system that makes it suitable for a wide range of semi-professional and professional camera setups. The 509HD's patented Advanced Balancing Recorder (ABR) allows you to quickly find, store and recuperate the correct balance position of the plate when using a particular combination of equipment. The 509HD also features Easy Link connectors for accessory attachment, an illuminated leveling bubble and replaceable rosettes for pan bar attachment on both sides of the head. The 509HD has a 100mm half ball video tripod mount.

- 12,8kg - 28.1lb (@ 55 C.O.G.)  
8,5kg - 18.7lb (@ 125 C.O.G.)
- 13,5kg - 29.8lb (@ 55 C.O.G.)  
9kg - 19.8lb (@ 125 C.O.G.)
- 17,8cm  
6.9in
- 3,8kg  
8.4lb
- 509PLONG

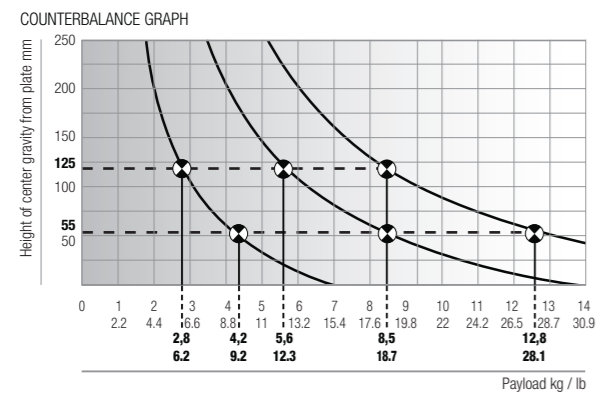

- 1 Pan drag control
- 2 Pan locking knob
- 3 Illuminated leveling bubble

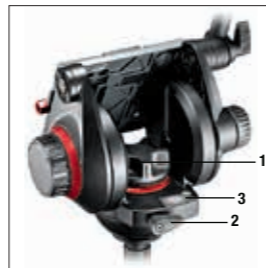

- 1 Tilt locking knob
- 2 Tilt drag knob
- 3 Sliding plate safety release button



- 1 Counterbalance adjustment knob
- 2 Sliding quick release plate
- 3 Sliding quick release knob
- 4 Advanced Balancing Recorder
- 5 Easy Link - 3/8" thread connection



### TECHNICAL SPECIFICATIONS

**Head base** 100mm half ball  
**Pan drag type** Fixed fluid cartridge (from 0 to max level)  
**Tilt drag type** Fixed fluid cartridge (from 0 to max level)  
**Counterbalance system** Variable 4 steps  
**Counterbalance weight** 0 - 2,8 - 5,6 - 8,5kg (0 - 6.2 - 12.3 - 18.7lb)  
**Safety payload** 9kg (19.8lb)  
**Leveling bubble** Available (illuminated with led)  
**Pan bar** Available (telescopic)

**Pan bar attachment** Available on right and left sides  
**Replaceable pan bar rosette** Yes, on both sides  
**Plate type** 509PLONG Quick Release with ABR  
**Plate travel** 72mm (28.1in)  
**Plate attachment** 3/8" and 1/4" camera screws + anti-rotation pin  
**Pan range** 360°  
**Tilt range** -60° +90°  
**Temperature range** -20° C +60° C



# 509HD Pro Fluid Video Head Kit



## 509HD, 536K KIT

- 12,8kg - 28.1lb (@ 55 C.O.G.)  
8,5kg - 18.7lb (@ 125 C.O.G.)
  - 13,5kg - 29.8lb (@ 55 C.O.G.)  
9kg - 19.8lb (@ 125 C.O.G.)
  - 87cm  
34.2in
  - 40,5cm  
15.8in
  - 217,5cm  
84.8in
  - 7,1kg  
15.7lb
- Head** 509HD  
**Tripod** Carbon Fiber 536  
**Bag** included



## MVK509TWINFC KIT

- 12,8kg - 28.1lb (@ 55 C.O.G.)  
8,5kg - 18.7lb (@ 125 C.O.G.)
  - 13,5kg - 29.8lb (@ 55 C.O.G.)  
9kg - 19.8lb (@ 125 C.O.G.)
  - 89,5cm  
35.2in
  - 43,5cm  
17.1in
  - 173cm  
68.1in
  - 7,5kg  
16.5lb
- Head** 509HD  
**Tripod** Carbon Fiber MVTTWINFC  
**Bag** included

## MVK509TWINFA KIT

- 12,8kg - 28.1lb (@ 55 C.O.G.)  
8,5kg - 18.7lb (@ 125 C.O.G.)
  - 13,5kg - 29.8lb (@ 55 C.O.G.)  
9kg - 19.8lb (@ 125 C.O.G.)
  - 89,5cm  
35.2in
  - 43,5cm  
17.1in
  - 173cm  
68.1in
  - 7,8kg  
17.2lb
- Head** 509HD  
**Tripod** Aluminium MVTTWINFA  
**Bag** included



# 504X Fluid Video Head



- variable **FDS** FLUID DRAG SYSTEM
- variable steps **CBS** COUNTER BALANCE SYSTEM
- 55** C.O.G.
- FLAT**

## MVH504XAH FLUID VIDEO HEAD

504X fluid video head is the evolution of the hugely successful 504HD. It's a more compact and lighter version that finally comes with flat base (base diameter 75 mm), developed to meet the needs of the most demanding videographers. The head is made from a brand-new catching aluminium design, and has a maximum payload of 12kg. Utilising Manfrotto's new fluid technology, the camera head allows you to capture judder-free smooth motion pans and tilts. It's never been easier for the operator to create premium-quality video capture, thanks to a 4-step counterbalance system which can carry payloads of up to 6.5 kg at 55mm C.O.G. That makes using a wide range of different cameras easier and more practical. Two easy link 3/8" thread connections allow an external monitor or other accessory equipment to be fitted on the head side. Head leveling is simple thanks to the clever backlit levelling bubble.

- 6,5kg 12kg 14,9cm 2kg 504PLONGR-1
- 14.3lb 26.5lb 5.8in 4.4lb

COUNTERBALANCE GRAPH

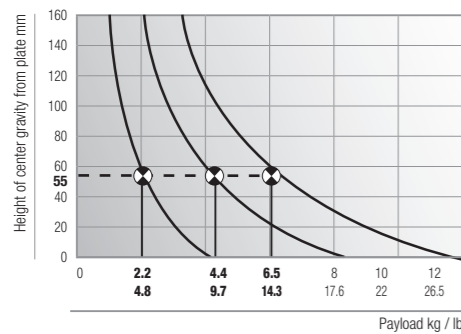

- 1 Pan drag control
- 2 Pan locking knob
- 3 Illuminated leveling bubble



- 1 Tilt locking knob
- 2 Tilt drag knob
- 3 Sliding plate safety release button
- 4 Easy Link - 3/8" thread connection



- 1 Counterbalance adjustment knob
- 2 Sliding quick release plate
- 3 Sliding quick release knob



### TECHNICAL SPECIFICATIONS

|                              |  |                                    |   |
|------------------------------|--|------------------------------------|---|
| <b>Head base</b>             | Flat   | <b>Pan bar attachment</b>          | Available on right and left sides               |
| <b>Pan drag type</b>         | Fixed fluid cartridge (from 0 to max level)    | <b>Replaceable pan bar rosette</b> | Yes, on both sides                              |
| <b>Tilt drag type</b>        | Fixed fluid cartridge (from 0 to max level)    | <b>Plate type</b>                  | 504PLONGR-1 Quick Release                       |
| <b>Counterbalance system</b> | Variable 4 steps                               | <b>Plate travel</b>                | 83mm (3.3in)                                    |
| <b>Counterbalance weight</b> | 0 - 2.2 - 4.4 - 6.5kg (0 - 4.8 - 9.7 - 14.3lb) | <b>Plate attachment</b>            | 3/8" and 1/4" camera screws + anti-rotation pin |
| <b>Safety payload</b>        | 12kg (26.5lb)                                  | <b>Pan range</b>                   | 360°  |
| <b>Leveling bubble</b>       | Available (illuminated with led)               | <b>Tilt range</b>                  | -60° +90°                                       |
| <b>Pan bar</b>               | Available (telescopic)                         | <b>Temperature range</b>           | -30° C +60° C                                   |



# 504X Fluid Video Head Kit



## MVK504XTWINMC KIT

- 6,5kg 12kg 86cm 75cm
- 14.3lb 26.5lb 33.8in 29.5in
- 169cm 5,3kg
- 66.5in 11.6lb

**Head** MVH504XAH  
**Tripod** Carbon Fiber MVTWINMC included  
**Bag**

## MVK504XTWINGC KIT

- 6,5kg 12kg 85cm 49cm
- 14.3lb 26.5lb 33.4in 19.2in
- 175cm 5,5kg
- 68.9in 12.2lb

**Head** MVH504XAH  
**Tripod** Carbon Fiber MVTWINGC included  
**Bag**

## MVK504XCTALL KIT

- 6,5kg 12kg 87cm 42cm
- 14.3lb 26.5lb 34.2in 16.5in
- 218cm 5,8kg
- 85.8in 12.8lb

**Head** MVH504XAH  
**Tripod** Carbon Fiber 536 included  
**Bag**

## MVK504XTWINMA KIT

- 6,5kg 12kg 86cm 45,5cm
- 14.3lb 26.5lb 33.8in 17,9in
- 169cm 5,6kg
- 66.5in 12.3lb

**Head** MVH504XAH  
**Tripod** Aluminium MVTWINMA included  
**Bag**



## MVK504XTWINGA KIT

- 6,5kg 12kg 85cm 49cm
- 14.3lb 26.5lb 33.5in 19.3in
- 175cm 5,8kg
- 68.9in 12.9lb

**Head** MVH504XAH  
**Tripod** Aluminium MVTWINGA included  
**Bag**

## MVK504XTWINFA KIT

- 6,5kg 12kg 89,5cm 45,5cm
- 14.3lb 26.5lb 35.2in 17.9in
- 173cm 6,2kg
- 68.1in 13.6lb

**Head** MVH504XAH  
**Tripod** Aluminium MVTWINFA included  
**Bag**

## MVK504XSNGFC KIT

- 6,5kg 12kg 89,5cm 44,5cm
- 14.3lb 26.5lb 35.2in 17.5in
- 171cm 5,8kg
- 67.3in 12.8lb

**Head** MVH504XAH  
**Tripod** Carbon Fiber MVTSNGFC included  
**Bag**



# 502 Fluid Video Heads



- variable
- fixed
- FLAT

## MVH502AH FLUID VIDEO HEAD

The 502 fluid head is designed for use with HD/SLR cameras and latest interchangeable lens cameras. It offers professional features such as highperformance variable fluidity and a counterbalance system. The 502 supports up to 7kg cameras and accessories, with a counterbalance setting designed to match the weight of the most popular cameras and their accessories as external monitors, lights or microphones. The 502's Easy Link attachment points mean that the weight of accessories can be supported directly by the head, rather than by the camera. The MVH502A has flat base mount with standard 3/8" thread.

- 4kg / 8.8lb
- 7kg / 15.4lb
- 13cm / 5.1in
- 1.7kg / 3.7lb
- 504PLONG

- 1 Sliding plate safety release button
- 2 Pan drag control
- 3 Leveling bubble

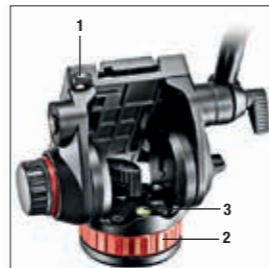

- 1 Pan locking knob
- 2 Tilt drag control
- 3 Easy link connectors



- 1 Tilt locking knob
- 2 Sliding quick release plate
- 3 Sliding quick release knob
- 4 Easy link connectors



COUNTERBALANCE GRAPH

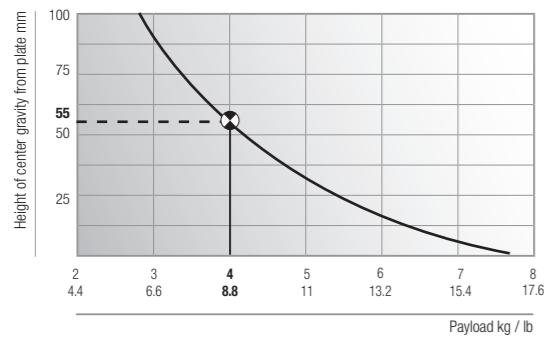

### TECHNICAL SPECIFICATIONS

|                              |   |                                    |   |
|------------------------------|---|------------------------------------|---|
| <b>Head base</b>             | Flat  | <b>Pan bar attachment</b>          | Available on right and left sides               |
| <b>Pan drag type</b>         | Fixed fluid cartridge (from 0 to max level) | <b>Replaceable pan bar rosette</b> | No  |
| <b>Tilt drag type</b>        | Fixed fluid cartridge (from 0 to max level) | <b>Plate type</b>                  | 504PLONG Quick Release                          |
| <b>Counterbalance weight</b> | Fixed @ 4kg (8.8lb)                         | <b>Plate travel</b>                | 85mm (3.3in)                                    |
| <b>Safety payload</b>        | 7kg (15.4lb)                                | <b>Plate attachment</b>            | 3/8" and 1/4" camera screws + anti-rotation pin |
| <b>Leveling bubble</b>       | Available                                   | <b>Pan range</b>                   | 360°  |
| <b>Pan bar</b>               | Available                                   | <b>Tilt range</b>                  | -80° +90°                                       |
|                              |   | <b>Temperature range</b>           | -20° C +60° C                                   |



# 502 Fluid Video Head Kit



## MVK502AM-1 KIT

- 4kg / 8.8lb
- 7kg / 15.4lb
- 75cm / 29.5in
- 70.5cm / 27.8in
- 156cm / 61.4in
- 3.86kg / 8.5lb

**Head** MVH502A  
**Tripod** Aluminum MVT502AM  
**Bag** included



## MVK502055XPRO3 KIT

- 4kg / 8.8lb
- 7kg / 15.4lb
- 74.5cm / 29.3in
- 70cm / 27.5in
- 183.5cm / 72.2in
- 4.2kg / 9.43lb

**Head** MVH502A  
**Tripod** Aluminum MT055XPRO3  
**Bag** included



## MVH502A,546BK-1 KIT

- 4kg / 8.8lb
- 7kg / 15.4lb
- 83cm / 32.7in
- 41cm / 16.1in
- 164.5cm / 64.8in
- 5.3kg / 11.68lb

**Head** MVH502A  
**Tripod** Aluminum 546B  
**Bag** included



## MVH502A,546GB-1 KIT

- 4kg / 8.8lb
- 7kg / 15.4lb
- 83cm / 32.6in
- 46cm / 18.1in
- 172cm / 67.7in
- 5.5kg / 12lb

**Head** MVH502AH  
**Tripod** Aluminum 546GB  
**Bag** included





# 500 Fluid Video Heads



- fixed **FDS** FLUID DRAG SYSTEM
- fixed **CBS** COUNTERBALANCE SYSTEM
- FLAT**

## MVH500AH FLUID VIDEO HEAD

The 500 is a lightweight video head featuring a wider platform to accommodate both HD/SLR and interchangeable lens camcorder, as well as a sliding plate that ensures the appropriate balance even when shooting with very long lenses. The 500 ensures smooth fluid shots and fine control of up to 5kg of equipment. Its side lock allows fast, secure and easy camera attachment. It has one Easy Link 3/8" connector to allow an external monitor or other accessory equipment to be fitted. The MVH500A has flat base mount with standard 3/8" thread.

|                |             |                |                |          |
|----------------|-------------|----------------|----------------|----------|
|                |             |                |                |          |
| 2,4kg<br>5.3lb | 5kg<br>11lb | 9,5cm<br>3.7in | 0,9kg<br>2.1lb | 500PLONG |

- 1 Locking knobs
- 2 CBS: Counterbalance System
- 3 Leveling bubble



- 1 FDS: Fluid Drag System
- 2 Locking knobs
- 3 Wider platform + longer sliding plate
- 4 Easy Link - 3/8" thread connection



- 1 FDS: Fluid Drag System
- 2 Side lock lever

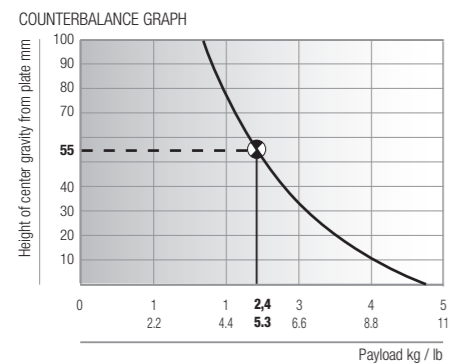
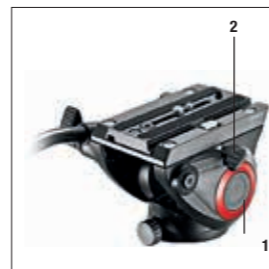

### TECHNICAL SPECIFICATIONS

|                       |                       |
|-----------------------|-----------------------|
| Head base             | Flat                  |
| Pan drag type         | Fixed fluid cartridge |
| Tilt drag type        | Fixed fluid cartridge |
| Counterbalance weight | Fixed @ 2,4kg (5.3lb) |
| Safety payload        | 5kg (11lb)            |
| Leveling bubble       | Available             |
| Pan bar               | Available             |

|                             |  |
|-----------------------------|--|
| Pan bar attachment          | Available on right and left sides                |
| Replaceable pan bar rosette | No   |
| Plate type                  | 500PLONG Quick Release with Side Lock            |
| Plate travel                | 100mm (3.9in)                                    |
| Plate attachment            | V3/8" and 1/4" camera screws + anti-rotation pin |
| Pan range                   | 360°   |
| Tilt range                  | -70° +90°  |
| Temperature range           | -20° C +60° C                                    |



# 500 Fluid Video Head Kit



## MVK500AM KIT

|                |             |                |                  |                 |               |
|----------------|-------------|----------------|------------------|-----------------|---------------|
|                |             |                |                  |                 |               |
| 2,4kg<br>5.3lb | 5kg<br>11lb | 72cm<br>28.3in | 67,5cm<br>26.3in | 154cm<br>60.6in | 3,16kg<br>7lb |

|        |                   |
|--------|-------------------|
| Head   | MVH500A           |
| Tripod | Aluminum MVT502AM |
| Bag    | included          |



## MVK500190XV KIT

|                |             |                  |                  |                   |                   |
|----------------|-------------|------------------|------------------|-------------------|-------------------|
|                |             |                  |                  |                   |                   |
| 2,4kg<br>5.3lb | 5kg<br>11lb | 72,2cm<br>28.4in | 50,3cm<br>19.8in | 149,3cm<br>58.7in | 173,3cm<br>68.2in |

|        |              |
|--------|--------------|
| Head   | MVH500AH     |
| Tripod | Aluminum     |
| Bag    | not included |



## MVH500AH, 755CX3 KIT

|                |             |                |              |                 |                 |
|----------------|-------------|----------------|--------------|-----------------|-----------------|
|                |             |                |              |                 |                 |
| 2,4kg<br>5.3lb | 5kg<br>11lb | 73cm<br>28.7in | 56cm<br>22in | 148cm<br>58.3in | 173cm<br>68.1in |

|        |                     |
|--------|---------------------|
| Head   | MVH500AH            |
| Tripod | Carbon Fiber 755CX3 |
| Bag    | included            |



# Video Tripods

The Manfrotto video tripod ranges have been created to cater to various types of uses and needs, offering both single and twin leg, aluminum and carbon fibre, in a variety of fast and traditional versions. There is no “one tripod fits all” approach: choices will depend on the camera configuration, special needs in terms of compactness, operating heights and lightness.

## Fast

Designed and engineered for the fastest set up time, high rigidity and sturdiness. 635 FST, thanks to FAST Twisting Lock Technology a synchronized closure mechanism between upper and lower locks, it controls the entire leg with a single lock!

The 645 FTT with FAST Lever Lock Technology gives users maximum leg control, with rapid and easy movement. Setting up a tripod has never been so quick! The single leg version is available in carbon fibre, and the twin leg in both carbon fibre and aluminum.



## Standard

The 545 and 535 are among the best sellers in the Video support segment: a wide range of twin legs in aluminum and carbon fibre and single leg in carbon fibre, all with a dedicated bowl attachment for video applications. A hybrid solution is available in single leg tripods, both in aluminum and carbon fibre. These have a levelling column, which offers a ready to go solution for professionals who work with both a small flat base fluid head and photo heads, and are looking for a versatile solution without losing the chance to level the head.



MVTWINFC  
645 FTT FAST TWIN LEG CARBON FIBER TRIPOD

The 645 FTT Fast Twin Carbon Tripod features a double tubing and FAST Lever Lock technology for the most robust support ever. The tripod is provided with a 2 in 1 half ball: a standard 100mm bowl along with a 75mm adapter to enable the use of a wider range of video heads. It also features a middle spreader lock. This range was developed with the primary objective of making video shooting easier by reducing set up times and maintenance. The synchronized closure mechanisms between the upper and lower locks, enable videographers to control the entire leg with a single lock and get to work in record time. The 645 FTT-Carbon is compatible with the 2 in 1 ground and middle telescopic spreader and it features a 3-angle selection mechanism for easy set up. It is equipped with spiked feet with rubber overshoes.

|              |                |                |                 |                |
|--------------|----------------|----------------|-----------------|----------------|
|              |                |                |                 |                |
| 25kg<br>55lb | 73cm<br>28.7in | 27cm<br>10.6in | 157cm<br>61.8in | 3,6kg<br>7.9lb |

### TECHNICAL SPECIFICATIONS

|                           |                                 |
|---------------------------|---------------------------------|
| Head attachment           | 100mm bowl and 75mm adapter     |
| Leveling bubble           | no                              |
| Locking type              | 2 in 1 Lever lock               |
| Leg angle setting         | by leg selector or mid spreader |
| Leg angle                 | 3 steps                         |
| Included mid-spreader     | yes                             |
| Included ground spreader  | no                              |
| Included spike foot shoes | yes                             |



MVTWINFA  
645 FTT FAST TWIN LEG ALU TRIPOD

The 645 FTT Fast Twin Alu Tripod features a double tubing and FAST Lever Lock technology for the most robust support ever. The tripod is provided with a 2 in 1 half ball: a standard 100mm bowl along with a 75mm adapter to enable the use of a wider range of video heads. It also features a middle spreader lock. However, the 3-angle selectors make the use of a spreader a matter of optional preference. This range was developed with the primary objective of making video shooting easier by reducing set up times and maintenance. The synchronized closure mechanisms between the upper and lower locks, enable videographers to control the entire leg with a single lock and get to work in record time. Moreover, the 645 FTT-Alu is compatible with the 2 in 1 ground and middle telescopic spreader and it features a 3-angle selection mechanism for easy set up. It is equipped with spiked feet with rubber.

|              |                |                |                 |                |
|--------------|----------------|----------------|-----------------|----------------|
|              |                |                |                 |                |
| 25kg<br>55lb | 73cm<br>28.7in | 27cm<br>10.6in | 157cm<br>61.8in | 3,9kg<br>8.6lb |

### TECHNICAL SPECIFICATIONS

|                           |                                 |
|---------------------------|---------------------------------|
| Head attachment           | 100mm bowl and 75mm adapter     |
| Leveling bubble           | no                              |
| Locking type              | 2 in 1 Lever lock               |
| Leg angle setting         | by leg selector or mid spreader |
| Leg angle                 | 3 steps                         |
| Included mid-spreader     | yes                             |
| Included ground spreader  | no                              |
| Included spike foot shoes | yes                             |



FAST  
TRIPODS

### MVTSNGFC 635 FST FAST SINGLE LEG CARBON FIBER TRIPOD

Manfrotto 635 Fast Single Tripod Carbon Fiber with Synchronized closure mechanisms between the upper and lower locks, has single tubing and features the FAST Twisting Lock, for secure locking with a single, easy gesture. The 635 FST tripod features a 75mm half ball and is compatible with a 60-mm half ball adapter (sold separately). In addition, it features Easy Link friction arm attachments compatible with Manfrotto anti rotation and Arri anti-twist pins. This enables users to attach an external monitor or any other accessory they may require without the risk of the arm rotating while in use. The Manfrotto 635 Fast Single Tripod was developed with the primary objective of making video shooting easier by reducing set up times and maintenance. The synchronized closure mechanisms between the upper and lower locks, enable videographers to control the entire leg with a single lock and get to work in record time. The new tripod provide maximum versatility, supporting the use of a broad choice of heads, and ensuring the utmost rigidity while also being extremely lightweight. Moreover, it is compatible with the 2 in 1 ground and middle telescopic spreader (which is sold as an optional accessory) and it features a 3-angle selection mechanism for easy set up. It is equipped with spiked feet with rubber overshoes for a firm grip and adaptability to the most diverse shooting locations.

|              |                |                  |               |                |
|--------------|----------------|------------------|---------------|----------------|
|              |                |                  |               |                |
| 20kg<br>44lb | 73,5cm<br>29in | 28,5cm<br>11,2in | 155cm<br>61in | 3,5kg<br>7,7lb |

#### TECHNICAL SPECIFICATIONS

|                           |                       |
|---------------------------|-----------------------|
| Head attachment           | 75mm bowl             |
| Leveling bubble           | no                    |
| Locking type              | 2 in 1 Twist Lock     |
| Leg angle setting         | by leg selector       |
| Leg angle                 | 3 steps (23°-50°-70°) |
| Included mid-spreader     | no                    |
| Included ground spreader  | no                    |
| Included spike foot shoes | yes                   |



### MVTWINMC TWIN LEG CARBON FIBER TRIPOD MIDDLE SPREADER

Two-stage, extremely rigid and stable carbon fibre tripod. It features an aluminum casting 100mm bowl and is provided with an aluminum adapter that converts the bowl into a 75mm. The tripod has a mid-level spreader with telescopic arms that helps you to set leg angles precisely. It is detachable, allowing the tripod to also be used in combination with the Manfrotto 165MV ground spreader, which is sold separately. Its leg locks are secure and reliable, and it is provided with twin spiked feet with rubber overshoes for solid grounding.

|              |                |                |                 |              |
|--------------|----------------|----------------|-----------------|--------------|
|              |                |                |                 |              |
| 20kg<br>44lb | 69cm<br>27.2in | 58,5cm<br>23in | 153cm<br>60.2in | 3kg<br>6.6lb |

#### TECHNICAL SPECIFICATIONS

|                           |                              |
|---------------------------|------------------------------|
| Head attachment           | 100mm bowl and 75 mm adapter |
| Leveling bubble           | no                           |
| Locking type              | lever locks                  |
| Leg angle setting         | by mid spreader              |
| Leg angle                 | 3 steps                      |
| Included mid-spreader     | yes                          |
| Included ground spreader  | no                           |
| Included spike foot shoes | yes                          |



### MVTWINGC TWIN LEG CARBON FIBER TRIPOD GROUND SPREADER

Two-stage, extremely rigid and stable carbon fibre tripod. Features an aluminum casting 100mm bowl and is provided with an aluminum adapter that converts the bowl into a 75mm. The tripod has a ground level spreader with telescopic arms that helps you to set leg angles precisely. It is also detachable, allowing the tripod to be also used in combination with the Manfrotto 537SPRB middle spreader and 565 rubber shoes (both items are sold separately). Moreover, the tripod has secure leg locks and reliable twin spiked feet are provided for external use, e.g. in the grass.

|              |                |                  |                 |              |
|--------------|----------------|------------------|-----------------|--------------|
|              |                |                  |                 |              |
| 20kg<br>44lb | 69cm<br>27.2in | 33,5cm<br>13.2in | 158cm<br>62.2in | 3,2kg<br>7lb |

#### TECHNICAL SPECIFICATIONS

|                           |                              |
|---------------------------|------------------------------|
| Head attachment           | 100mm bowl and 75 mm adapter |
| Leveling bubble           | no                           |
| Locking type              | lever locks                  |
| Leg angle setting         | by mid spreader              |
| Leg angle                 | 3 steps                      |
| Included mid-spreader     | no                           |
| Included ground spreader  | yes                          |
| Included spike foot shoes | yes                          |



### MVTTWINMA TWIN LEG ALU TRIPOD MIDDLE SPREADER

Two-stage, rigid and stable aluminum tripod. Features an aluminum casting 100mm bowl and is provided with an aluminum adapter that converts the bowl into a 75mm. The tripod has a mid-level spreader with telescopic arms that helps you to set leg angles precisely. It is also detachable, allowing the tripod to also be used in combination with the Manfrotto 165MV ground spreader, which is sold separately. Its leg locks are secure and reliable, and it is provided with twin spiked feet with rubber overshoes for solid grounding.

### MVTTWINGA TWIN LEG ALU TRIPOD GROUND SPREADER

Two-stage, rigid and stable aluminum tripod. It features an aluminum casting 100mm bowl and is provided with an aluminum adapter that converts the bowl into a 75mm. The tripod has a ground level spreader with telescopic arms that helps you to set leg angles precisely. It is detachable, allowing the tripod to also be used in combination with the Manfrotto 537SPRB middle spreader and 565 rubber shoes, which are sold separately. Its leg locks are secure and reliable, and it is provided with twin spiked feet for external use, e.g. in the grass.



25kg 69cm 58,5cm 153cm 3,3kg  
55lb 27.2in 23in 60.2in 7.2lb



25kg 69cm 33,5cm 158cm 3,55kg  
55lb 27.2in 13.2in 62.2in 7.8lb

#### TECHNICAL SPECIFICATIONS

|                           |                             |
|---------------------------|-----------------------------|
| Head attachment           | 100mm bowl and 75mm adapter |
| Leveling bubble           | no                          |
| Locking type              | lever locks                 |
| Leg angle setting         | by mid spreader             |
| Leg angle                 | 3 steps                     |
| Included mid-spreader     | yes                         |
| Included ground spreader  | no                          |
| Included spike foot shoes | yes                         |

#### TECHNICAL SPECIFICATIONS

|                           |                             |
|---------------------------|-----------------------------|
| Head attachment           | 100mm bowl and 75mm adapter |
| Leveling bubble           | no                          |
| Locking type              | lever locks                 |
| Leg angle setting         | by ground selector          |
| Leg angle                 | 3 steps                     |
| Included mid-spreader     | no                          |
| Included ground spreader  | yes                         |
| Included spike foot shoes | yes                         |



### MVT502AM TELESCOPIC TWIN LEG TRIPOD

The MVT502AM is a two-stage tripod for lightweight applications. Its telescopic-twin legs are made of elliptical aluminum tubes that help reduce torsion and give the tripod a good balance of high performance and reduced weight. Other features include a fixed mid-level spreader for increased rigidity and faster set-up, a rubber strap for safer, easier transportation, and new high-grip soft rubber feet. The MVT502AM's 75mm half-bowl matches mid-range Manfrotto video heads.



15kg 61,5cm 57cm 143,5cm 1,92kg  
33lb 24.2in 22.4in 56.5in 4.2lb

#### TECHNICAL SPECIFICATIONS

|                           |              |
|---------------------------|--------------|
| Head attachment           | 60/75mm bowl |
| Leveling bubble           | no           |
| Locking type              | lever locks  |
| Leg angle setting         | not setting  |
| Leg angle                 | 19°          |
| Included mid-spreader     | yes          |
| Included ground spreader  | no           |
| Included spike foot shoes | no           |



### 536 MPRO CARBON FIBER 3-STAGE VIDEO TRIPOD

The 4-section, single tube 536 video tripod is incredibly stable, even though it offers a very high load capacity and a very tall maximum height. Despite its open height, it's compact when folded. The single tube structure makes it light in weight, ergonomic and easy-to-use. Features our new leg angle selector, developed for quick, easy and precise independent leg angle adjustments. The half-bowl attachment fits industry-standard 75mm or 100mm half ball heads; an adaptor is supplied to switch between the two sizes.



25kg 72cm 26cm 203cm 3.4kg  
55lb 28.3in 10.2in 79.9in 7.5lb

#### TECHNICAL SPECIFICATIONS

|                           |                       |
|---------------------------|-----------------------|
| Head attachment           | 75/100mm bowl         |
| Leveling bubble           | no                    |
| Locking type              | lever locks           |
| Leg angle setting         | by leg selector       |
| Leg angle                 | 3 steps (23°-50°-70°) |
| Included mid-spreader     | no                    |
| Included ground spreader  | no                    |
| Included spike foot shoes | no                    |

### 528XB PRO HEAVY VIDEO TRIPOD

The 528XB is the ideal location tripod, with a massive 50 kg (110.2lb) load capacity. Its tubes are made of a combination of stainless steel for strength under heavy loads and aluminum for reduced weight. It includes a versatile mid-level spreader with telescopic ratchet braces that click into place in each of the preset positions for faster deployment. Each brace can be individually set, allowing each tripod leg to be positioned separately.



50kg 99cm 73cm 148cm 8.1kg  
110lb 40in 28.7in 58.3in 17.9lb

#### TECHNICAL SPECIFICATIONS

|                           |                                 |
|---------------------------|---------------------------------|
| Head attachment           | 100mm bowl + half ball included |
| Leveling bubble           | no                              |
| Locking type              | turn locks                      |
| Leg angle setting         | by mid spreader                 |
| Leg angle                 | from 25° to 41°                 |
| Included mid-spreader     | yes                             |
| Included ground spreader  | no                              |
| Included spike foot shoes | no                              |



### 755CX3 MDEVE MAGFIBER VIDEO TRIPOD

Two-stage tripod with a perfect combination of low weight and high load capacity thanks to its carbon fibre and magnesium construction. Features a levelling column for a quick and easy set-up, and leg angle selectors for independent leg angle adjustment.



7kg 63.5cm 46.5cm 139cm 164mm 1.9kg  
15.4lb 25in 18.3in 54.7in 64.6in 4.2lb

#### TECHNICAL SPECIFICATIONS

|                           |  |
|---------------------------|--|
| Head attachment           | 50mm levelling flat base with 3/8" screw |
| Leveling bubble           | yes                                      |
| Locking type              | lever locks                              |
| Leg angle setting         | by leg selector                          |
| Leg angle                 | 4 steps (23°-47°-66°-89°)                |
| Included mid-spreader     | no                                       |
| Included ground spreader  | no                                       |
| Included spike foot shoes | no                                       |

### 755XB MDEVE ALUMINUM VIDEO TRIPOD

Two-stage aluminium tripod. Features a levelling column for quick and easy set-up, and leg angle selectors for independent leg angle adjustment.

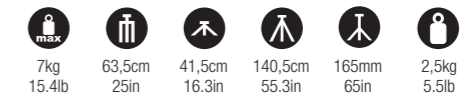

7kg 63.5cm 41.5cm 140.5cm 165mm 2.5kg  
15.4lb 25in 16.3in 55.3in 65in 5.5lb

#### TECHNICAL SPECIFICATIONS

|                           |  |
|---------------------------|--|
| Head attachment           | 50mm levelling flat base with 3/8" screw |
| Leveling bubble           | yes                                      |
| Locking type              | lever locks                              |
| Leg angle setting         | by leg selector                          |
| Leg angle                 | 4 steps (23°-47°-66°-89°)                |
| Included mid-spreader     | no                                       |
| Included ground spreader  | no                                       |
| Included spike foot shoes | no                                       |



# Dollies

In order to customize your tripod for every different environment, the Manfrotto tripod accessories range includes a complete set of different dollies and spreaders.



**114 VIDEO DOLLY**

Heavy duty, super sturdy, designed for use with large video tripods; individually braked wheels with cable guards. Folds for transporting. Includes 3/8" attachment which allows you to attach a head for low angle shooting.

- 60kg  
132.3lb
- 8kg  
17.6lb
- 112cm  
44.1in



**114MV PORTABLE DOLLY**

Same as 114 dolly with ability to accept spiked tip tripods. Includes 3/8" attachment which allows you to attach a head for low angle shooting.

- 60kg  
132.3lb
- 6.2kg  
13.7lb
- 112cm  
44.1in



**181B FOLDING AUTODOLLY**

Single lever braking system controls all three 80mm wheels. It folds legs for transporting and storage. Includes 3/8" attachment which allows you to attach a head for low angle shooting.

- 25kg  
55.1lb
- 4.5kg  
9.9lb
- 127cm  
50in



**127 VIDEO DOLLY**

Designed for light and medium weight tripods. The 76mm wheels have a sure-lock feature that raises the wheels free off the ground so that the dolly then rests on extended feet. Includes 3/8" attachment which allows you to attach a head for low angle shooting.

- 10kg  
22lb
- 2.4kg  
5.3lb
- 110cm  
43.3in



**127VS BASIC DOLLY**

Everything that the 127 has with the ability for a variable spread for the legs. Suitable for standard and spiked feet. Includes 3/8" attachment which allows you to attach a head for low angle shooting.

- 10kg  
22lb
- 3.4kg  
7.5lb
- 78-114cm  
30.7-44.9in



# Spreaders



MVASPR2N1 **SPREADER 2N1**

The new telescopic spreader enables mid and ground-level shooting. Setting the correct leg angle and ensuing tripod footprint has never been so easy, thanks to the quick release mechanism. This new spreader has been re-engineered and made more robust, and guarantees a flexible link between the spreader and tripod leg.



0,52kg  
1.13lb



MVASPRM **MIDDLE SPREADER**

The Manfrotto Middle Spreader allows you to set the proper leg angle and resulting tripod footprint thanks to its telescopic arms that help you to set leg angles accurately.



0,28kg  
0.6lb



165 **TRIPOD SPREADER**

Universal tripod spreader with variable diameter width controls from 80 to 130cm (31.5 to 51.2in).



0.65kg  
1.43lb



80-130cm  
31.5-51.2in



165MV **TRIPOD SPREADER FOR SPIKED FEET**

Universal tripod spreader with variable diameter width controls from 80mm to 130mm (31.5 to 51.2in). It accepts spiked tip tripod.



0.65kg  
1.43lb



80-130cm  
31.5-51.2in

| TRIPOD MODELS | DOLLY |       |     |       |      | SPREADER |           |     |       |
|---------------|-------|-------|-----|-------|------|----------|-----------|-----|-------|
|               | 114   | 114MV | 127 | 127VS | 181B | MVASPRM  | MVASPR2N1 | 165 | 165MV |
| MVTTWINFA     |       | •     |     |       | •    | •        | •         |     | •     |
| MVTTWINFC     |       | •     |     |       | •    | •        | •         |     | •     |
| MVTSNGFC      |       | •     |     |       | •    |          | •         |     |       |
| MVTTWINMA     |       | •     |     |       | •    | •        |           |     | •     |
| MVTTWINGA     |       | •     |     |       | •    |          |           |     | •     |
| MVTTWINMC     |       | •     |     |       | •    | •        |           |     | •     |
| MVTTWINGC     |       | •     |     |       | •    |          |           |     | •     |
| MVT502AM      |       |       |     |       |      |          |           |     |       |
| 536           | •     |       | •   | •     |      |          |           | •   |       |
| 528XB         | •     |       | •   | •     |      |          |           | •   |       |
| 755CX3        |       |       |     |       |      |          |           | •   |       |
| 755XB         |       |       |     |       |      |          |           | •   |       |

| HEAD MODELS | PLATES |          |          |          |             |            |          |        |          |          |
|-------------|--------|----------|----------|----------|-------------|------------|----------|--------|----------|----------|
|             | 501PL  | 500PLONG | 501PLONG | 504PLONG | 504PLONGR-1 | 504PLONGRL | 509PLONG | 357PLV | 357PLV-1 | 357PLONG |
| MVH612AH    | •      |          | •        | •        | •           | •          | •        |        |          |          |
| MVH608AH    | •      |          | •        | •        | •           | •          | •        |        |          |          |
| 526-1       |        |          |          |          |             |            |          | •      | •        | •        |
| 509HD       | •      | •        | •        | •        | •           | •          | •        |        |          |          |
| MVH504XAH   | •      | •        | •        | •        | •           | •          | •        |        |          |          |
| MVH502AH    | •      | •        | •        | •        | •           | •          | •        |        |          |          |
| MVH500AH    |        | •        |          |          |             |            |          |        |          |          |

PLEASE NOTE: this chart only shows technical compatibility. When assembling the products always consider the maximum load of the component with the lowest loading capacity.



# XPRO monopods+ video

When shooting space is limited, when the amount and weight of equipment has to be kept to a minimum, when set-up speed is of primary importance, or the location is unsuitable for a tripod, a monopod is often the best solution to helping support a video camera and reduce camera shake. New XPRO monopods+ video are a Manfrotto world-first: a patented system designed to help videographers obtain superior image quality from the kind of fluid camera movements unachievable with a standard monopod. An innovative fluidity based on spherical joint deeped into a fluid cartridge makes the user total free in terms of fluid movement, not limited to 1 axis but extended to all the possible positions (3 axes) and furthermore the new monopod can also be locked in vertical position to make panoramic rotations of the camera as smooth and judder-free as possible. The new XPRO monopods+ FLUIDTECH base also has three retractable feet, which give it firmer footing and help keep the camera stable and reduce unwanted tilt.



## MVMXPROBASE FLUID BASE FOR MONOPOD

- Fluidtech base - 3D fluidity
- Detachable fluid base also compatible with XPRO monopods+

The FLUIDTECH base quickly transforms a photo monopod into a video monopod, enabling the ultimate shooting smoothness on pan, tilt and swivel. The three retractable feet make it extremely portable when folded. The base easily attaches onto the last section of the new XPRO monopods+ with the exception of the MVMXPROA3B.

- 10,5cm  
4.1in
- 11,5cm  
4.5in
- 0,4kg  
0.9lb

- Aluminum
- QPL QUICK POWER LOCK
- 5
- FLUIDTECH



## MVMXPROA5 FLUID ALUMINUM 5 SECTION VIDEO MONOPOD

The XPRO monopod+ Aluminum 5-section is a professional fluid video monopod made to satisfy videographers who need a highly portable, high-performance solution they can easily carry. It is the most compact Manfrotto aluminium video monopod in the new range to mount the fluid base (MVMXPROBASE) with the latest FLUIDTECH technology.

- 6kg  
13.2lb
- 52,5cm  
20.7in
- 153cm  
60.2in
- 1,1kg  
2.4lb

- Carbon fiber
- QPL QUICK POWER LOCK
- 5
- FLUIDTECH



## MVMXPROC5 FLUID CARBON FIBER 5 SECTION VIDEO MONOPOD

The XPRO monopod+ Carbon Fiber 5-section is a professional fluid video monopod made to satisfy videographers who need a highly portable, high-performance solution they can easily carry when they are travelling. The MVMXPROC5 is the lightest Manfrotto carbon fiber monopod in the new range to mount the fluid base (MVMXPROBASE) with the latest FLUIDTECH technology.

- 5 kg  
11lb
- 60,5cm  
23.8in
- 188cm  
74in
- 1kg  
2.2lb

- Aluminum
- QPL QUICK POWER LOCK
- 4
- FLUIDTECH



## MVMXPROA4 FLUID ALUMINUM 4 SECTION VIDEO MONOPOD

The XPRO monopod+ Aluminium 4-section is a professional fluid video monopod made to satisfy videographers who leverage the height of their monopod to get above crowds and to achieve a wide range of shooting angles. This monopod is equipped with Manfrotto's fluid base (MVMXPROBASE).

- 8kg  
17.6lb
- 68cm  
26.8in
- 192cm  
75.6in
- 1,2kg  
2.6lb

- Aluminum
- QPL QUICK POWER LOCK
- 4
- CBS COUNTER BALANCE SYSTEM fixed
- FLUIDTECH



## MVMXPRO500 FLUID ALUMINUM VIDEO MONOPOD WITH 500 VIDEO HEAD

The XPRO monopod+ Aluminium 4-section features a specially adapted 500 Fluid Video Head. This monopod is equipped with Manfrotto's fluid base (MVMXPROBASE). The MVMXPRO500US exploits the MVH500AH's counterbalance system for managing heavier equipment. The combination of fluidity provided by both the 500 head and the FLUIDTECH base make this the perfect kit for demanding videographers who need clever, fast-to-set-up and easy to use support for their professional video footage.

- 2,4kg  
5.3lb
- 5 kg  
11lb
- 78cm  
30.7in
- 203cm  
79.9in
- 2,1kg  
4.6lb
- 500PLONG





# Gimbal



## MVG460 GIMBAL

The Manfrotto MVG460 is a Professional 3-Axis Stabilized Handheld Gimbal designed for DSLR cameras. Able to support up to 4.6 kg (10 lb), it's perfect for photographers, videographers, vloggers and bloggers looking for a versatile device with a variety of modes for dynamic shooting. The Gimbal comes with a LCD touch screen that allows you to switch working mode and control the rotation and parameters with one hand. Control options include photo/video capture, focus, zoom, sensitivity adjustment, white balance, and exposure value.

Modes includes:

- Inception mode
- Portrait mode for TikTok
- Selfie mode
- Time-lapse

It's simple to control your device, adjust settings and perform various functions remotely, using the Manfrotto Gimbal App. To prevent shaking, the motor is equipped with independent locking for each axis. It also features a unique quick installation system, designed with a secondary structure and compatible with the Manfrotto and the ARCA Swiss Type standard, which allows photographers to quickly change equipment. After levelling the camera, it can be quickly removed and installed without the need to level again.

### Specifications

|                             |  |
|-----------------------------|--|
| Weight                      | 1,656 kg (3.65 lb)                           |
| Dimensions                  | 17,5 x 24 x 42,9 cm (6.88 x 9.44 x 16.88 in) |
| Payload                     | 4,6 kg (10 lb)                               |
| Tilting Angle               | 230°   |
| Rolling Angle               | 360°   |
| Panning Angle               | 360°   |
| Certifications              | CE, CA PROP 65, FCC, IC, RCM, RoHS, REA      |
| Controllable Tilt Range     | +175° to -55°                                |
| Powered By (Batteries)      | Li-Ion                                       |
| Charging Mode               | Charger (USB port charging not supported)    |
| Attachment Type             | 1/4"-20 standard tripod mount                |
| Charging Time               | 5 hours                                      |
| Usage Time                  | Up to 12 hours                               |
| Connection                  | Wi-Fi, USB-C port                            |
| App                         | Manfrotto Gimbal App                         |
| Minimum Working Temperature | -10 °C                                       |
| Maximum Working Temperature | +45 °C                                       |



Product Contents



## MVG220 GIMBAL

The Manfrotto MVG220 is a Professional 3-Axis Stabilized Handheld Gimbal designed for mirrorless and DSLR cameras. Designed for dynamic shooting, it can support up to 2.2 kg (5.5 lb) making it a perfect choice for photographers, videographers, vloggers and bloggers looking for a versatile device with various modes for supreme flexibility. The Gimbal comes with a LCD touch screen that allows you to easily switch working mode and control the rotation and parameters with one hand. This includes control photo/video capture, focus, zoom, sensitivity adjustment, white balance, and exposure value.

Modes include:

- Inception mode
- Portrait mode (for TikTok)
- Selfie mode
- Time-lapse

To control your device, adjust settings and perform various functions remotely, you can also download and use the Manfrotto Gimbal App. To prevent shaking, the motor is equipped with independent locking for each axis. It also features a unique quick installation system, designed with a secondary structure and compatible with the Manfrotto and the ARCA Swiss Type standard, which allows photographers to quickly change equipment. After levelling the camera, the camera can be quickly removed and installed without the need to level again. The kit included also features a detachable, versatile arm that switches between a single handle and an underslung position to capture even the most extreme shooting angles.

### Specifications

|                             |   |
|-----------------------------|---|
| Weight                      | 1,1 kg (2.42 lb)                            |
| Dimensions                  | 7,1 x 20,9 x 35 cm (2.79 x 8.22 x 13.78 in) |
| Payload                     | 2,2 kg (4.85 lb)                            |
| Tilting Angle               | 230°  |
| Rolling Angle               | 360°  |
| Panning Angle               | 360°  |
| Certifications              | CE, CA PROP 65, FCC, IC, RCM, RoHS, REACH   |
| Controllable Tilt Range     | +175° to -55°                               |
| Powered By (Batteries)      | Li-Ion                                      |
| Charging Mode               | USB port                                    |
| Attachment Type             | 1/4"-20 standard tripod mount               |
| Charging Time               | 1,5 hours                                   |
| Usage Time                  | Up to 7 hours                               |
| Connection                  | Wi-Fi, USB-C port                           |
| App                         | Manfrotto Gimbal App                        |
| Minimum Working Temperature | -10 °C                                      |
| Maximum Working Temperature | 45 °C                                       |
| Maximum Working Temperature | +45 °C                                      |



Product Contents



# GimBoom



## MVGBF-CF GIMBOOM

GimBoom is the revolutionary new FAST boom developed by Manfrotto with universal fitting for your Gimbal. From ground level to overhead position (drone perspective), the new Manfrotto GimBoom allows you to get more versatile and flexible use from your Gimbal, raising your production values to the next level. Thanks to its standard 3/8" and 1/4" top attachment screw, the GimBoom guarantees an easy connection with your Gimbal. It's exceptionally compact (hand baggage size with 51cm (20in) minimum operating height) and lightweight (800g./1.76 lb) And, thanks to its carbon-fibre construction - capable of taking a payload of 6.5 kg (4.3 lb) at maximum extension - the GimBoom is also incredibly strong. The unique FAST Twisting Lock makes it quick and simple to deploy and extend, allowing the user to control the entire boom with a single gesture. With two risers and three telescopic sections, the full extended length is more than double (1.15m/45.27in) the minimum operating length (0.51m/20.07in), while the intuitive graphic design means locking and unlocking the boom have never been easier. Three thread connectors arranged at 120° on the top of the middle section enable the GimBoom to pair with dedicated GimBoom accessories, with a handy rubber cap to avoid damage when placing it on the ground.

### Specifications

|                             |                        |
|-----------------------------|------------------------|
| Weight                      | 0,8 kg (1.76 lb)       |
| Top Attachment              | 1/4" screw, 3/8" screw |
| Leg Sections                | 3                      |
| Min Height                  | 51,5 cm (20 in)        |
| Maximum Height              | 115 cm (45.27 in)      |
| Closed Length               | 51,5 cm (20 in)        |
| Safety Payload Weight       | 6.5 kg (14.3 lb)       |
| Upper Disc Diameter         | 47 mm (1.85 in)        |
| Colour                      | Black/Red              |
| Easy Link                   | No                     |
| Leg Lock Type               | Twist Lock             |
| Legs Tube Diameter          | 29.2, 24.8, 20.4 mm    |
| Material                    | Carbon Fiber           |
| Maximum Working Temperature | 60 °C                  |
| Minimum Working Temperature | -30 °C                 |



# Gimbal Accessories



## MVGFF GIMBAL FOLLOW FOCUS

The Manfrotto Follow Focus is the perfect accessory for Manfrotto Gimbals, MVG220 and MVG460. It allows you to precisely control focus using the multi-function knob, making shooting easier and more accurate. Based on a brushless motor and high-precision intelligent chip, it controls the motor rotation and gives you real-time tracking in a few simple steps:

1. Fix the lens gear to the camera's focus ring position
2. Fasten the fixed bracket to the quick release plate of the Gimbal with a hexagonal screw, and insert the aluminium tube.
3. Insert the follower into the aluminium tube and lock the fixed thumb screw on the follower. Move the aluminium tube to adjust the front and rear position to make the follower gear and the lens gear engage, and lock the fixed thumb screw on the fixed bracket.
4. Insert the data cable into the USB port of the fixed plate and the installation is complete.



## MVGEXT GIMBAL CARBON EXTENSION

275-mm-Manfrotto carbon pole Quick and easy to attach, It allows you to explore a wider range of perspectives and creative angles.



## MVGRC GIMBAL REMOTE CONTROL

The Manfrotto Remote Control is the best choice if you are looking for an efficient remote control for your gimbal.

With only one hand it is possible to manage the gimbal, all the remote controlled functions, the direction of the lens, the on/off switch and the operating mode, for easy and controlled shooting.

It can be adjusted and controlled within a range of 10-15m and all the LCD display parameters can be seen (power, Bluetooth, modes ) clearly.



# Accessories

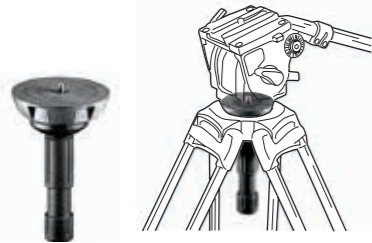

**500BALL 100MM HALF BALL**

Length 17cm (6.7in). Attachment: 3/8" male thread.



**500BALLSH 100MM SHORT HALF BALL**

Length 12,5cm (4.9in). Attachment: 3/8" male thread.

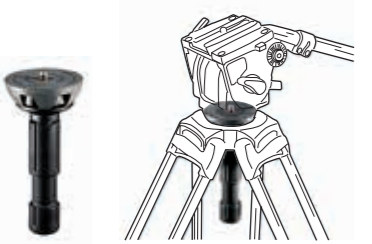

**520BALL 75MM HALF BALL**

Length 16cm (6.3in). Attachment: 3/8" male thread.



**520BALLSH 75MM SHORT HALF BALL**

Length 11,5cm (4.5in). Attachment: 3/8" male thread.



**529B TWIN LEG HI-HAT, 100MM HALF BOWL**

529B Hi-Hat enables you to get shots from the dog's perspective. The 529B has a 100mm half-bowl, adjustable leg angles to mount the camera in the tightest or lowest of locations and thanks to the built-in spreader you can simply use the 529B on any even surface. The feet are rubber-padded to protect delicate surfaces and have a hole so that the 529B can be screwed to a ladder, apple-box or a sheet of wood.

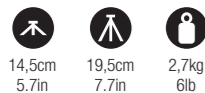

14,5cm  
5.7in    19,5cm  
7.7in    2,7kg  
6lb



**MVT535HH SINGLE LEG HI HAT, 75-60MM HALF BOWL**

This Hi-Hat has a robust aluminium design for maximum strength. It also offers slider support and a table tripod application for heavy cameras, which means you can enjoy even more shooting opportunities. Better still, the Ø 75-60mm bowl also allows for very quick levelling so you'll never be a second too late for that all-important shot. Adjust the height from 11.6cm to 24.3cm with the easy-to-use leg angle selector, and use the adapter (supplied) to convert the half bowl from 75mm to 60mm with ease.



11,6cm  
4.5in    24,3cm  
9.5in    1,2kg  
2.6lb



# Remote Controls

**MVR901EPLA PAN BAR REMOTE CONTROL**



Pan-bar remote control for cameras with LANC (Sony and Canon).

- REC/STOP
- Push Button
- Max-speed Zoom potentiometer
- Stand-by push button
- RET push buttons (play back latest 5s)
- IRIS Push Button
- REC, Zoom and Focus indicator LED's
- Zoom and focus direction knob (by software)
- Multi-speed Zoom and Focus knob
- Focus/Zoom switch
- Auto/Man Focus switch



**MVR901EPEX PAN BAR REMOTE CONTROL**



Remote control with standard pan bar for Sony PMW EX-family cameras

- REC/STOP push button
- Zoom direction switch
- Multi-speed Zoom knob
- Max-speed Zoom potentiometer
- RET push button (plays back latest 5s)
- Power indicator LED
- Fast zoom push buttons



**522AV ADAPTOR CABLE FOR AV-R SONY CONNECTOR**

Made for video cameras with the AV-R plug, the 522AV converts the possibility to connect to these type of cameras all the Manfrotto remote controls.



**522SCA REMOTE CONTROL CABLE STANDARD**

2.5mm male/male jack coiled cord cable measuring 140cm (55in) when extended, supplied as standard with all the units.



**MVR901ECPL CLAMP-ON REMOTE CONTROL**



Remote control can be set-up for LANC (Canon/Sony) and Panasonic cameras.

- LANC/Panasonic switch
- Stand-by push button (for LANC only)
- REC/STOP push button
- Multi-speed Zoom knob
- REC/STOP LED (for LANC only)
- Zoom direction knob (by software)



**MVR901ECEX CLAMP-ON REMOTE CONTROL**



Remote control compatible with Sony PMW EX-family cameras.

- REC/STOP push button
- Zoom direction switch
- Multi-speed Zoom knob
- Max-speed Zoom potentiometer
- RET push button (plays back latest 5s)
- Power indicator LED
- Fast zoom push buttons

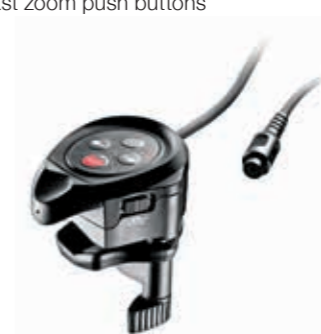

**MVR901ECLA LANC REMOTE CONTROL**



Advanced remote control for LANC (Canon/Sony) cameras.

- Stand-by push button
- REC/STOP push button
- Zoom and focus direction knob (by software)
- Multi-speed Zoom and Focus knob
- Max-speed zoom potentiometer
- Rec, Zoom and Focus indicator LED's



Key to symbols





# Photo Tripods

Manfrotto's mission is to develop specific ranges of supports for the particular needs of all customers, taking into account different levels of skill and varied ambitions in photography. Every series has specific characteristics and intended applications, with products differing for every level of performance, features and complexity. However, all of the products share the Manfrotto attitude: to offer no more than the necessary features, so as not to add unnecessary complexity and always providing the highest level of quality.

## Salon

The Salon tripod range, ideal for studio application, offers support for every camera size. Features smooth operating counter balanced horizontal gear driven crossarm, supplied complete with camera support platform, and equipped with retractable wheels for easier placement around the studio.

## Studio

Rugged, tough and strong, the Studio tripod range is ideal for studio and indoor applications. It has been developed to stabilize the extra loads associated with large equipment and to guarantee maximum precision. Each tripod has a geared center column with a "non-rollback" mechanism. The top spider is in reinforced die cast aluminum and the legs are stabilized by an adjustable mid level spreader. With a wide range of sizes and weights the Manfrotto Studio family meets the needs of all the professional and advanced photographers.

## 055

The 055 is our best-known and most successful tripod for professional photographers; this latest redesign continues to build on the range's heritage, but improves its performance in terms of stiffness and strength and also makes it faster to set-up, easier to use, and more versatile than ever.

## 190

The 190 is a unique tripod that holds compactness and more transportability together with incredible stiffness. Aimed mainly to hobbyists, it offers ultra-versatile settings that make it easier to release the imagination and creativity of every photographer. The 190 model is Manfrotto's most popular tripod and has become the "pivot" for all the photo-supports range.



# Salon Series

## 806 MINI SALON 190

Designed for 35mm and medium format cameras, the Mini Salon 190 allows working heights from 56cm/22in to 182cm/71.7in. Counterbalanced column is black anodised aluminum and is mounted on a heavy cast iron base with two pivoting wheels which lock firmly into place with individual wheel locks. Features smooth operating counter balanced horizontal gear driven crossarm, supplied complete with camera support platform. The crossarm support casting features a built-in accessory tray 20x28cm/7.9x11in. Arm length: 80cm/31.5in. Horizontal arm length: 75cm/29.5in.

|              |                 |                        |                 |              |                     |
|--------------|-----------------|------------------------|-----------------|--------------|---------------------|
|              |                 |                        |                 |              |                     |
| 56cm<br>22in | 182cm<br>71.7in | 85x54cm<br>33.5x21.3in | 190cm<br>74.8in | 34kg<br>75lb | 5kg-10kg<br>11-22lb |

## 809 SALON 230

Just slightly lighter in construction, the Salon 230 has a 8cm/3.1in diameter black anodised aluminum column with a working height of 221cm/87in provided with an adjustable counter-balanced sliding horizontal 80cm/31.5in crossarm. The camera support platform allows movement in a solid angle of 360°. Large sized wheels in the heavy cast base and single pedal control facilitate easy positioning and quick, rock solid locking. The cross-arm support casting features a built-in accessory tray 33x28cm/13x11in. Supplied complete with camera support platform and counter-balanced crossarm.

|                |               |                      |                 |                 |                          |
|----------------|---------------|----------------------|-----------------|-----------------|--------------------------|
|                |               |                      |                 |                 |                          |
| 57cm<br>22.4in | 221cm<br>87in | 94x69cm<br>37x27.2in | 232cm<br>91.3in | 64kg<br>141.1lb | 13kg-15kg<br>28.7-33.1lb |

## 816 SUPER SALON 280

Our Top-of-the-Line stand, the Super Salon 280 brings the ultimate in stability to new heights in your studio. The rugged column is mounted on a heavy-duty cast "T" base- easy to move around because of its smooth-rolling wheels. They can be locked into position with just one step on the single control pedal. The Super Salon 280 has a 10cm/3.9in diameter black anodised aluminum column and a 100cm/39.4in horizontal camera arm that travels 62cm/24.4in. The arm has precise rack and pinion drive, and is accurately counterbalanced to move smoothly up and down. The camera support platform allows movement in a solid angle of 360°. Supplied with counterbalanced crossarm, camera support platform and accessory tray.

|                |                  |                         |                  |                 |                          |
|----------------|------------------|-------------------------|------------------|-----------------|--------------------------|
|                |                  |                         |                  |                 |                          |
| 60cm<br>23.6in | 274cm<br>107.9in | 100x70cm<br>39.4x27.6in | 284cm<br>110.2in | 80kg<br>176.4lb | 13kg-15kg<br>28.7-33.1lb |





# Studio Series



161MK2B SUPER PRO TRIPOD

The Super Pro is the largest and strongest tripod in the studio range, developed to be the best working horse for the studio photographer. It allows for an impressive and wide range of shooting perspectives thanks to the height range, 2,7m/105.1 max and 44cm/17.3in minimum, and the possibility to independently set leg angles. The rugged aluminum construction with large diameter aluminum tubes (the largest in the studio range) and strong castings, the adjustable center brace and the self locking geared column makes it an ultra stable and solid studio platform. The revolutionary center brace system can be operated in a symmetric or asymmetric way. This allows you to achieve two important results: fast positioning by locking the braces so that all of the legs will spread to the same angle and open instantly, or individual setting of the angle of each leg for the ultimate in tripod versatility. Rubber feet with retractable spiked feet and level are standard equipment. Ideal for all large format cameras.

Leg section diameters in mm: 40, 35, 30.

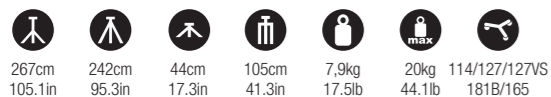

267cm 105.1in  
44cm 17.3in  
105cm 41.3in  
7.9kg 17.5lb  
20kg 44.1lb  
114/127/127VS  
181B/165



475B PRO GEARED TRIPOD

The Pro Geared is smaller and lighter than the Super Pro tripod. Made of the same rugged long lasting quality, it provides a strong and stable shooting platform and yet it is light enough for frequent repositioning on the studio floor. It is an ideal solution for smaller studios and traditional still life shootings. Like the Super Pro, the 475B Pro Geared Tripod incorporates a unique center brace structure system, reliable quick-action leg locks, non-rollback three faceted center column, spirit level and rubber/metal spiked feet. The revolutionary center brace system can be operated in a symmetric or asymmetric way. This allows you to achieve two important results: fast positioning by locking the braces so that all of the legs will spread to the same angle and open instantly, or individual setting of the angle of each leg for the ultimate in tripod versatility. To avoid annoying delays in leveling the tripod, the telescopic center braces have been designed with two "click stop" positions that allow you to easily find the same spread angle on all three legs.

Leg section diameters in mm: 35, 30, 25.



188cm 74in  
162cm 63.8in  
43cm 16.9in  
80cm 31.5in  
4.3kg 9.5lb  
12kg 26.5lb  
114/127/127VS  
181B/165



058B TRIAUT TRIPOD

The Triaut is an innovative tripod, strong and stable especially developed for Studios with a limited floor space and for all applications that require frequent equipment repositioning or photographic set re-arrangement. With smaller tube diameters and lighter construction, this unique tripod allows for a fast leg adjustment, for all three at the same time or single independently, thanks to a patented system. This system permits the legs to be extended, the tripod leveled (spirit level provided) and locked in seconds without 'fiddling' with individual leg adjustments. Telescoping the legs is achieved by activating the same release. While being shorter of the Super Pro tripod, it keeps a good versatility in terms of height range, it features the ability to adjust all angles individually and secure them with Manfrotto telescopic struts and the geared column. Favoured for medium format up to large cameras. Rubber feet with retractable spikes are standard. Includes carrying strap.

Leg section diameters in mm: 30, 25, 20.

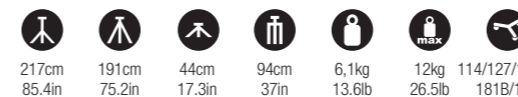

217cm 85.4in  
191cm 75.2in  
44cm 17.3in  
94cm 37in  
6.1kg 13.6lb  
12kg 26.5lb  
114/127/127VS  
181B/165



028B TRIMAN TRIPOD

The Triman tripod completes the studio range with another smart Manfrotto solution developed for Studio with limited floor space. Thanks to the long geared center column, this tripod guarantees a very good max height with a small foot print. Thought for frequent repositioning, it features smaller aluminum tubes for light weight. Ideal for traditional still life, it allows to go very close to the subject, making it a great tripod for macro shooting too. The geared center column has a non roll-back feature and has a three-aded 3/8" mount on the bottom of the column to allow low angle shots. Twin shank leg design, built-in spirit level and rubber feet with retractable spikes are standard features. The tripod uses a center column strut design for added stability. Includes a mid level spreader and carrying strap. Ideal for cameras up to medium format. Leg section diameters in mm: 25, 20, 19 tandem.

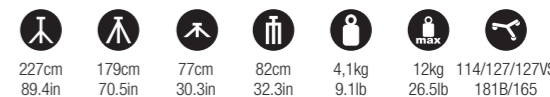

227cm 89.4in  
179cm 70.5in  
77cm 30.3in  
82cm 32.3in  
4.1kg 9.1lb  
12kg 26.5lb  
114/127/127VS  
181B/165



# 055 Series



- CF carbon fiber
- 90° COLUMN
- EASY LINK
- QPL QUICK POWER LOCK
- 3



MT055CXPRO3  
3-SECTION CARBON FIBER TRIPOD

The new 3-section 055, in its carbon fiber version, delivers maximum rigidity combined with the lightest components. The outcome is a masterpiece of engineering dedicated to all those photographers who want the best from their tripod and want it to be easily transportable. The 100% carbon fiber tubes increase leg rigidity and absorb vibration, stabilizing the equipment under any conditions, and dramatically reducing the weight compared to aluminum tubes.

- 170cm 66.9in
- 140cm 55.1in
- 9cm 3.5in
- 63cm 24.8in
- 2kg 4.4lb
- 9kg 16.6lb

- CF carbon fiber
- 90° COLUMN
- EASY LINK
- QPL QUICK POWER LOCK
- 4



MT055CXPRO4  
4-SECTION CARBON FIBER TRIPOD

The 055 carbon fiber tripod in its 4-section version results more compact when folded for even easier transportation. Despite the smaller size of the MT055CXPRO4, the carbon fiber legs ensure there's no compromise in terms of rigidity or vibration absorption.

- 170cm 66.9in
- 140cm 55.1in
- 9cm 3.5in
- 54cm 21.3in
- 2.1kg 4.6lb
- 9kg 16.6lb

- Al aluminum
- 90° COLUMN
- EASY LINK
- QPL QUICK POWER LOCK
- 3



MT055XPRO3  
3-SECTION ALUMINUM TRIPOD

The aluminum 055 redefines the state of art of traditional 3-section metal tripods. Thanks to its size and design, and above all to the careful choice of materials used, the 055 delivers an unprecedented level of stiffness.

- 170cm 66.9in
- 140cm 55.1in
- 9cm 3.5in
- 61cm 24in
- 2.5kg 5.5lb
- 9kg 16.6lb



# 055 Series



MK055XPRO3-3W  
**3-SECTION ALUMINUM KIT WITH XPRO 3-WAY HEAD**

The 055 Aluminum 3-section tripod is also available in kit in combination with a 3 way head. The 3 way head kit incorporates the brand new XPRO 3 Way Head (MHXPRO-3W - with quick release camera plate). The XPRO 3 way head has retractable levers which make it ultra-compact when closed, and also features new controls that allow the friction of portrait and tilt movements to be set, giving more control over framing while the locking knob is open.

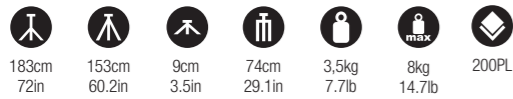

183cm 72in  
153cm 60.2in  
9cm 3.5in  
74cm 29.1in  
3.5kg 7.7lb  
8kg 14.7lb  
200PL



MK055XPRO3-BHQ2  
**3-SECTION ALUMINUM TRIPOD WITH XPRO HEAD RC2**

The must-have shooting kit for passionate photographers. The 055 Aluminium 3-section tripod with XPRO Ball Head includes a flexible 200PL plate so you can use it with many devices. It also features a sturdy tripod and ball head, all of which have been manufactured to the highest quality standards in Italy. Feel free to attach an LED light, reflector or another accessory via the Easy Link connector, and benefit from a professional-standard ball head and a levelling bubble for enhanced precision. All the equipment you need to achieve outstanding results.

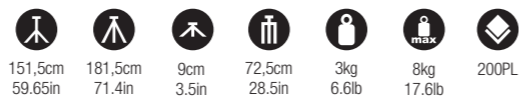

151,5cm 59.65in  
181,5cm 71.4in  
9cm 3.5in  
72,5cm 28.5in  
3kg 6.6lb  
8kg 17.6lb  
200PL



# 190 Series



MT190CXPRO4  
**4-SECTION CARBON FIBER TRIPOD**

The 4-section 190 in its Carbon Fiber version it is the perfect choice for all those photographers who don't want to accept any compromise both in stability and in portability. The 4-section legs allow an impressive compact dimension while the 100% Carbon Fiber tubes increase the legs rigidity and absorb vibration stabilizing the equipment in any condition.



160cm 63in  
135cm 53.1in  
8cm 3.1in  
52,5cm 20.7in  
1,65kg 3.6lb  
7kg 12.9lb



# 190 Series



MT190XPRO3  
3-SECTION ALUMINUM TRIPOD

The 190XPRO3, with its three section aluminum legs, is the right choice for providing high stability even when using long lenses. Its key feature is the 90° column mechanism, which allows the column to be extended vertically as normal, or horizontally to open up a wide range of framing and shooting possibilities; this makes the 190XPRO3 an extremely versatile tripod. Moreover, the limited number of sections cut down the set up time thanks to the comfortable and strong single-handed grip of Quick Power Lock levers that block and unblock each leg section.

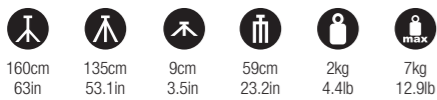

160cm 135cm 9cm 59cm 2kg 7kg  
63in 53.1in 3.5in 23.2in 4.4lb 12.9lb



MT190XPRO4  
4-SECTION ALUMINUM TRIPOD

The 190XPRO4 it is the right choice for all those photographers wanting a strong and reliable support even when travelling. It's key feature is the 90° column mechanism, which allows the column to be extended vertically as normal, or horizontally to open up a wide range of framing and shooting possibilities; this makes the 190XPRO4 an extremely versatile tripod. Thanks to the additional 4 section, legs can be collapsed to a more compact dimension, enhancing transportability.

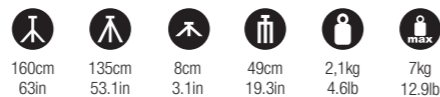

160cm 135cm 8cm 49cm 2.1kg 7kg  
63in 53.1in 3.1in 19.3in 4.6lb 12.9lb



MT190X3  
3-SECTION ALUMINUM TRIPOD

The 190X is a compact, essential, excellent built-in 3-section aluminum tripod. Its key feature is the ground level adaptor which enables the tripod to reach ultra-low positions. Its Quick Power Lock levers provide extreme locking grip and can be released with just one hand in a single movement. The top casting of the 190X has an Easy Link connector to support a photo or video accessory on an extending arm, turning the tripod into a mobile studio.

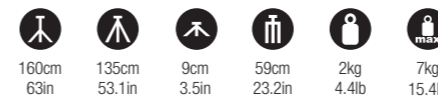

160cm 135cm 9cm 59cm 2kg 7kg  
63in 53.1in 3.5in 23.2in 4.4lb 15.4lb





# 190 Series



**MK190XPRO3-3W**  
**3-SECTION ALUMINIUM TRIPOD WITH XPRO 3-WAY HEAD**

The 190 Aluminum 3-section tripod in combination with a 3 way head. The 3 way head kit incorporates the brand new XPRO 3 Way Head (MHXPRO-3W - with quick release camera plate). The XPRO 3 way head has retractable levers which make it ultra-compact when closed, and also features new controls that allow the friction of portrait and tilt movements to be set, giving more control over framing while the locking knob is open.

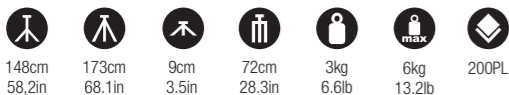

148cm 58.2in | 173cm 68.1in | 9cm 3.5in | 72cm 28.3in | 3kg 6.6lb | 6kg 13.2lb | 200PL



**MK190XPRO4-3W**  
**4-SECTION ALUMINIUM TRIPOD WITH XPRO 3-WAY HEAD**

Same as MK190XPRO3-3W but with Aluminum 4-section tripod.



148cm 58.2in | 173cm 68.1in | 8cm 3.1in | 62cm 24.4in | 3.1kg 6.8lb | 6kg 13.2lb | 200PL



**MK190XPRO3-BHQ2**  
**3-SECTION ALUMINIUM TRIPOD WITH XPRO BALL HEAD RC2**

The 190 Aluminum 3-section tripod with XPRO Ball Head includes a flexible 200PL plate so you can use it with many devices. It also features a sturdy tripod and ball head, all of which have been manufactured to the highest quality standards in Italy. Feel free to attach an LED light, reflector or another accessory via the Easy Link connector, and benefit from a professional-standard ball head and a levelling bubble for enhanced precision. All the equipment you need to achieve outstanding results.

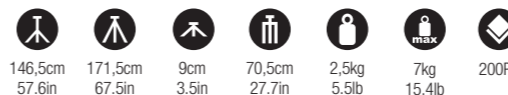

146,5cm 57.6in | 171,5cm 67.5in | 9cm 3.5in | 70,5cm 27.7in | 2,5kg 5.5lb | 7kg 15.4lb | 200PL



**MK190XPRO4-BHQ2**  
**4-SECTION ALUMINIUM TRIPOD WITH XPRO BALL HEAD RC2**

Same as MK190XPRO3-BHQ2 but with Aluminum 4-section tripod.



146,5cm 57.6in | 171,5cm 67.5in | 8cm 3.15in | 60,5cm 23.8in | 2,5kg 5.6lb | 7kg 15.4lb | 200PL



# Photo Heads

The Manfrotto heads range offers a wide selection of different models to tailor the equipment according to any specific need and application. Thanks to Manfrotto's broad experience each model of head is specifically designed to effectively and efficiently satisfy the requirements of our customers, always insuring the best result. Although they vary in technical solutions, materials, dimensions and payloads, all the Manfrotto heads are characterized by the same high level of quality and innovation. Excellent materials, innovative solutions and attention to ergonomic detail are common key aspects to Manfrotto heads, providing not only exceptional results but a unique shooting experience. Detail is designed to always guarantee the best way to take the best image in any situation with any equipment.

## Ball Heads

Ball heads are the most popular heads in the range, useful for all required situations especially frequently setting the camera position and taking multiple, different shots from different angles. The main advantages of these heads are multi angle versatile repositioning and fast lock and unlock action.



## 3-Way Heads

Manfrotto's 3-Way heads are the best choice when controlling the camera position with a good level of precision is required. The possibility to independently control the movement in three different directions allows you to precisely set the position of the camera in all situations, when it's necessary to pay maximum attention to the image composition, like in macro photography, still life, art photography.



## Geared Heads

The Manfrotto Geared heads are the most precise heads on the market. The Manfrotto geared mechanism was the first introduced in the market providing the best level of precision thanks to the millimetric control of the movement on each axis. They are the best option when maximum precision is required, for example when correcting the perspective in architectural shooting or studio still-life photography.



# Ball Heads



MHXPRO-BHQ2  
**BALL HEAD XPRO WITH 200PL QUICK RELEASE PLATE**

The new XPRO Ball Head is the perfect union between innovative technical solutions and design. XPRO Ball Head features a new triple locking system which guarantees camera position stability, avoiding drifting thanks to three wedges which enclose and block the sphere. Its friction control helps the user balance the weight of camera equipment and, thanks to the two leveling bubbles, fine adjustments can be made with the locking knobs open. Moreover, its new polymer rings have substituted that unpleasant, messy grease, ensuring smooth, accurate and less jerky camera movement.

- 11,5cm 4.5in
- 0,5kg 1.1lb
- 10kg 22.05lb
- 200PL
- Pan 360°
- Lateral Tilt -90° +40°

MHXPRO-BHQ6  
**BALL HEAD XPRO WITH ARCA-SWISS QUICK RELEASE PLATE**

Same as the MHXPRO-BH2 but with Top Lock, the MSQ6PL (Arca-Swiss compatible) is the perfect solution for experienced professionals wanting to feel totally secure, even when using expensive and heavy high-end camera gear.

- 11,5cm 4.5in
- 0,52kg 1.15lb
- 10kg 22.05lb
- MSQ6PL
- Pan 360°
- Lateral Tilt -90° +40°



# 3-Way Heads



## 229 3D SUPER PRO 3-WAY HEAD

3D Super Pro Head gives you complete control for that perfect shot thanks to its expert tripod head design. High quality design makes this kit ideal for your photography work. Independent controls on all three axis help you secure precise framing positions. Accuracy is aided by the built-in bubble levels indicating the horizontal and vertical levels. An innovative quick release camera plate makes the entire tripod head safe for you and your gear. The secondary safety catch adds a layer of protection for your equipment while you can focus on setting up quickly and smoothly on-set. Equipped with industry standard 1/4" and 3/8" screws and the ability to hold devices up to 12Kg, you can trust in the practicality of this tripod head.

- 16cm / 6.3in
- 1.9kg / 4.2lb
- 12kg / 26.5lb
- 030-14
- Pan 360°
- Frontal Tilt -25° +90°
- Lateral Tilt -90° +30°



## 808RC4 3-WAY HEAD WITH RC4 QUICK RELEASE PLATE

The 808RC4 streamlines our range of 3-way heads by incorporating new elements while maintaining all the features you loved. There are two balance springs in the vertical tilt (forward/backward) and horizontal tilt (left/right) movements. These springs enable you to more comfortably handle heavier camera loads (such as very long lenses) with minimal effort. Both springs can be turned off in case normal head operation is required. The head is comprised of aluminum and designed in a manner to support up to 8kg/17.6lb yet lightweight and small enough to pack in any camera kit. The standard quick release system is used to accommodate larger camera platforms and incorporates dual axis bubble levels to achieve level shots. Camera attachment: 1/4" and 3/8" screw.

- 15.6cm / 6.1in
- 1.4kg / 3.1lb
- 8kg / 17.6lb
- 410PL
- Pan 360°
- Frontal Tilt -30° +90°
- Lateral Tilt -30° +90°



## MHXPRO-3W XPRO 3-WAY HEAD

The XPRO 3 Way Head is compact, precise and reliable. Its sturdily aluminum body guarantees lightness and durability. The compact closed size that makes the XPRO so easy to pack and carry is down to its retractable levers that can be extended when needed. Friction controls on the XPRO 3-Way Head's tilt and portrait axes help balance the weight of camera equipment so that fine framing adjustments can be made with the locking knobs open, only locking everything down once everything's ready. And with 3 leveling bubbles on the head, composition can be levelled precisely incamera, reducing post production work.

- 13cm / 5.12in
- 1kg / 2.2lb
- 8kg / 17.6lb
- 200PL
- Pan 360°
- Frontal Tilt -30° +90°
- Lateral Tilt -30° +90°



# Geared Heads



400  
**STUDIO GEARED HEAD**

This unique head offers precise geared movement in 3 directions. Fold away rotating handles for pan and tilt; and side to side leveling by a separate handle. In addition, the tension holding the round quick release plate can be released to allow fine adjustment with complete safety. Designed to mount on either studio column stands or larger tripods, this geared head for medium and large format cameras, provides the ultimate in fine adjustment and control to achieve the exact framing required. Three 1/4" screws for camera attachment included.

- 16cm 6.3in
- 2,6kg 5.7lb
- 10kg 22lb
- 400PL-LOW 400PL-MED 400PL-HIG
- Pan 360°
- Frontal Tilt -90° +30°
- Lateral Tilt -7.5° +7.5°



405  
**PRO GEARED HEAD**

Speed and digital precision are stunning in the latest 405 Pro Geared Head. It provides ideal support and fast, pinpoint positioning for professional medium format cameras. The 405 Pro Geared Head was designed specifically to meet the more exacting, time-sensitive needs of busy professional digital photographers who shoot with medium format or 35mm camera/back with payloads up to 7,5kg/16.5lb. It utilizes large, easy-to-grip knobs that provide smooth, positive, geared control through pan and frontal and lateral tilt. In addition to its 3-D geared functions, the 405 also incorporates a unique feature that allows you to instantly disengage the gears and roughly position the camera by hand, then instantly reengage them for ultra-precise final alignment. Camera attachment: 1/4" and 3/8" screw.

**PATENTED**

- 16cm 6.3in
- 1,6kg 3.5lb
- 7,5kg 16.5lb
- 410PL
- Pan 360°
- Frontal Tilt -30° +90°
- Lateral Tilt -90° +30°



410  
**JUNIOR GEARED HEAD**

Extremely compact, this unique head offers gear movement in three directions, pan, tilt and side to side tilt. The head incorporates a quick release camera plate system and is suitable for 35mm SLR and medium format cameras.

Camera attachment: 1/4" and 3/8" screw.

**PATENTED**

- 13cm 5.1in
- 1,2kg 2.7lb
- 5kg 11lb
- 410PL
- Pan 360°
- Frontal Tilt -30° +90°
- Lateral Tilt -90° +30°



MHXPRO-3WG  
**XPRO GEARED HEAD**

The new XPRO Geared head is the perfect combination between lightness and precision of movement, together with a functional premium Italian design. Thanks to its body in Adapto Technopolymer, it enhances compactness and transportability, weighing only a mere 750gr/1.65lb and supporting up to 4kg/8.8lb. Combining two different movement systems, the XPRO Geared head guarantees fine-tuned compositions thanks to the geared movement of knobs rotation and a quick position changes thanks to Fast Movement Levers.

- 13cm 5.1in
- 0,75kg 1.65lb
- 4kg 8.8lb
- 200PL
- Pan 360°
- Frontal Tilt -20° +90°
- Lateral Tilt -90° +20°



# 360 Virtual Reality

The complete modular offer for VR content filming.



## Extensions

- MBOOMCFVR-S  
VR Small Carbon Fibre Extension Boom
- MBOOMCFVR-M  
VR Medium Carbon Fibre Extension Boom
- MBOOMCFVR-L  
VR Large Carbon Fibre Extension Boom
- MBOOMAVR  
VR Medium Aluminium Extension Boom

## Bases

- MBASECONVR  
VR Small Aluminium Base
- MBASEPROVR  
VR Small Levelling Base
- MTCFVR  
VR Big Carbon Fibre Base

## Kits



### MSTANDVR VIRTUAL REALITY ALUMINIUM COMPLETE STAND

The base has a levelling leg that quickly levels equipment, so you're always ready to shoot when the need arises. The column has a double interchangeable attachment on top: by simply screwing the upper disc, users can easily and rapidly move from a 1/4" to a 3/8" male attachment, according to the type of 360° device they want to use.

- 212cm  
83.5in
- 1,15kg  
2.5lb
- Alu



### MKPROVR VIRTUAL REALITY KIT WITH ALUMINIUM MINI TRIPOD AND EXTENSION BOOM

It is very small and lightweight and always ready to support a small 360° camera. The kit is composed of a table top tripod and a dual-section column extension: both are made of rugged, heavy-duty aluminium, which makes them extremely sturdy for their compact size. The kit holds a payload up to 2 kg. It features sturdy legs with sure-grip tips for stability

- 29cm  
11.4in
- 0,2kg  
0.44lb
- Alu

## Extensions

Manfrotto VR boom extensions maximize camera height according to the type of shooting you are doing. They can be connected to all bases in the Manfrotto VR range, so you can reach a wide variety of heights.



### MBOOMCFVR-S VR SMALL CARBON FIBER EXTENSION BOOM

- 80cm  
31.5in
- 33cm  
12.99in
- 2kg  
4.4lb
- CF



### MBOOMCFVR-M VR MEDIUM CARBON FIBER EXTENSION BOOM

- 200cm  
78.7in
- 62.5cm  
24.61in
- 2kg  
4.4lb
- CF



### MBOOMCFVR-L VR LARGE CARBON FIBER EXTENSION BOOM

- 470cm  
185in
- 103.5cm  
40.75in
- 2kg  
4.4lb
- CF



### MBOOMAVR VR MEDIUM ALUMINIUM EXTENSION BOOM

- 200cm  
78.7in
- 61cm  
24in
- 1,5kg  
3.3lb
- Alu

## Accessories



### MDOLLYVR VR ADJUSTABLE DOLLY

The Manfrotto VR Adjustable Dolly is the perfect accessory to give your imagination the maximum freedom of movement. It allows you to achieve stunning 360 shots when you quickly need to move your support around, continuously changing viewpoints.



### MHPANOVVR VR PANORAMIC HEAD WITH MULTIPLE SLIDING PLATES

With its 4kg payload, it works perfectly with Professional DSLRs. It features sliding plates to position the camera over the panoramic rotation axis, a sliding plate that rotates around the front/back tilt axis.



### MCUPVR VR PUMP CUP WITH SPIGOT ADAPTER

The VR Suction Cup is perfect for use on any flat non-porous surface. It comes complete with a 5/8" adapter spigot made of durable, lightweight brass that won't rust or deteriorate over time. It features a ball-joint socket which rotates within a half hemisphere.



### M035VR VR SUPER CLAMP

The Manfrotto VR Super Clamp is easy to use, strong and reliable. It is completely made of aluminium, and is the perfect VR clamp for professionals looking for a dependable, practical tool for their VR shooting. It supports up to 15kg, but thanks to its compact aluminium body weighs only 430 g.

## Bases

Manfrotto VR bases provide a stable support, compact enough not to appear in the 360° shot. They guarantee the necessary stability if you need to go a few meters off the ground with the 360° camera. You can choose between different dimensions and material, according to the type of shooting you usually do.



### MBASECONVR VR SMALL ALUMINIUM BASE

- 40,8cm  
16.06in
- 0,6kg  
1.3lb
- Alu



### MBASEPROVR VR SMALL LEVELLING BASE

- 26,5cm  
10.43in
- 1,6kg  
3.53lb
- Alu



### MTCFVR VR BIG CARBON FIBER BASE

- 160cm  
62.99in
- 3,63kg  
8lb
- CF



# Accessories

## Heads - Plates



030-14  
030-38  
**HEXAGONAL PLATE**

030-14 with 1/4" screw.  
030-38 with 3/8" screw.



030ARCH-14  
030ARCH-38  
**ARCH. HEXAGONAL PLATE**

Provides alignment for 90° shots with 35mm SLR camera.  
030ARCH-14 with 1/4" screw.  
030ARCH-38 with 3/8" screw.

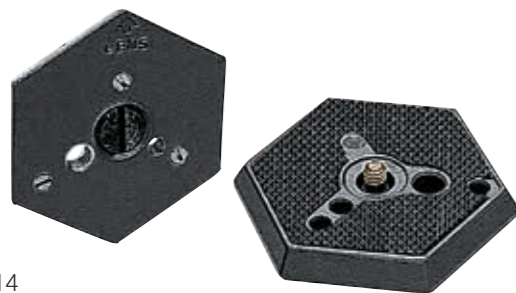

130-14  
130-38  
**HEXAGONAL PLATE**

130-14 with 1/4" screw.  
130-38 with 3/8" screw.

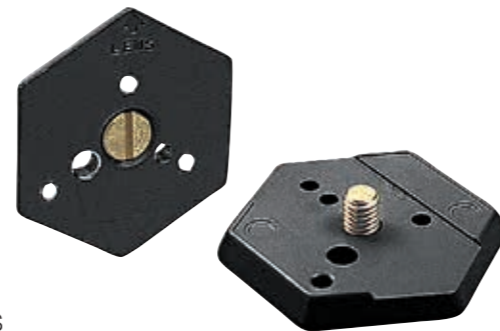

030HAS  
**HEXAGONAL PLATE**

For Hasselblad cameras.  
Supplied with both 1/4" and 3/8" screw.



030VHS-14  
**HEXAGONAL PLATE WITH VHS PIN**

Plate with VHS Locating Pin 1/4"



200PL  
**RC2 COMPATIBLE QUICK RELEASE PLATE**

Easy-to-use, intuitive and practical. Slim and made from lightweight and durable aluminium. Supplied with 1/4" camera fixing screw and 3/8" adapter.



200PL-PRO  
**RC2 AND ARCA-SWISS COMPATIBLE QUICK RELEASE PLATE**

Full aluminium plate ideal for quickly attaching cameras onto the world's most widespread standard head attachments: Manfrotto RC2 and Arca-swiss style. Supplied with 1/4" camera fixing screw and 3/8" adapter.



MSQ6PL  
**ARCA-SWISS COMPATIBLE QUICK RELEASE PLATE**

Camera attachment plate for use with Manfrotto's Arca-compatible Q6 Top Lock quick release system. Also compatible with Arca-style systems from other manufacturers.

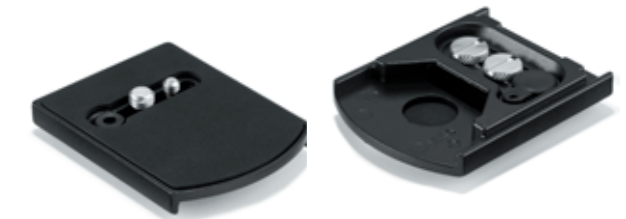

410PL  
**RC4 COMPATIBLE PLATE**

Supplied with 1/4" and 3/8" camera fixing screws.



400PL-LOW  
400PL-MED  
400PL-HIG  
**QUICK RELEASE PLATE FOR 400 GEARED HEAD**

400PL-LOW = h 13mm/0.5in  
400PL-MED = h 23mm /0.9in  
400PL-HIG = h 42mm 1.7in.



# Accessories

## Adapters



625  
**HEXAGONAL PLATE ADAPTOR**

Supplied with 1/4" and 3/8" camera fixing screws. Fixing 1/4" and 3/8" tread. 030 hexagonal plate included. Equipped with 2 built-in spirit levels.



323  
**RC2 QUICK RELEASE ADAPTOR**

Supplied with 1/4" camera fixing screws. Fixing 1/4" and 3/8" tread. 200PL rectangular plate included.



454  
**MICRO POSITIONING PLATE**

Ideal for macro photography to make precise positioning movements to achieve the perfect framed shot, for QTVR and other precise copy/repro work, the new sliding plate has finger-tip control for hairsbreadth positioning but with a simple lock-release lever for fast set-up. Two plates can be interlocked at 90° for full lateral/ forward/ back movement (over 120mm/4.7in). In extruded aluminum, the plate has 1/4" and 3/8" holes and screws for tripod and camera mounting. Dimension: 180x57,5x15mm/7.1x2.3x0.6in.



MSQ6  
**Q6 TOP LOCK QUICK RELEASE ADAPTOR**

Supplied with 1/4" camera fixing screw and with a Q6 Arca-compatible plate. The plate and the adaptor are also compatible with Arca-style systems from other manufacturers.



394  
**RC4 QUICK RELEASE ADAPTOR**

Supplied with 1/4" and 3/8" camera fixing screws. Fixing 1/4" and 3/8" thread. 410PL plate included. Equipped with 2 built-in spirit levels.



577  
**SLIDING PLATE ADAPTOR**

Supplied with 1/4" and 3/8" camera fixing screws. Fixing 1/4" and 3/8" thread. 501PL sliding plate included.



357  
**SLIDING PLATE ADAPTOR**

Supplied with 1/4" and 3/8" camera fixing screws. Fixing 1/4" and 3/8" thread. 357PLV sliding plate included. Dimension: 140x44x6mm/5.5x1.7x0.2in.



# Accessories



627  
**BASIC PANORAMIC HEAD ADAPTOR**

Basic panoramic adapter that can be mounted on top of a head, monopod, or tripod. The adapter camera platform has a graduated scale in millimeters to set the camera position during different shooting sequences and a dual 1/4" and 3/8" camera fixing screw. This accessory can be connected to a head, monopod, or tripod by a 3/8" female attachment.



190XLAA  
**LOW ANGLE ADAPTER FOR 190 SERIES**

The Low Angle Adapter allows great shooting creativity, when placed on the top casting and combined with the 4 leg angles of the new 190 tripods, it allows you to reach ultra-low positions.

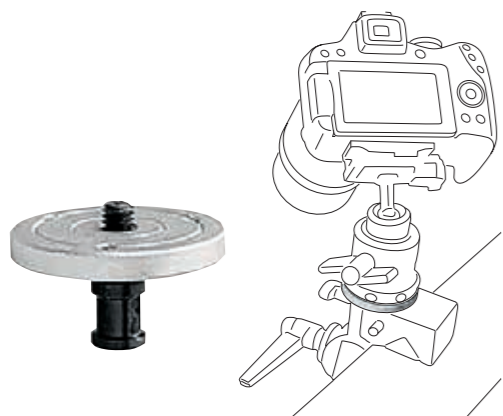

208  
**CAMERA MOUNTING ADAPTOR**

Allows use of 3/8" camera mounting plate in to 16mm socket. Compatible with Super Clamp 035C and 494RC2 or 496RC2 Ball Head for example. Diameter: 59,5mm/2.2in.



208HEX  
**CAMERA MOUNTING ADAPTER HEXAGONAL PIN**

Its main feature is the hexagonal pin, which, compared to the 208's round one, gives more grip when used to hold heavy cameras mounted on photo or video heads in combination with accessories like the super clamp 035.



393  
**LONG LENS MONOPOD BRACKET**

Specifically developed for use with very long lenses on monopods. Key features: friction base which enables the bracket to pan on monopod, also can be used on a tripod; two rubber hand grips plus rubber protection to prevent damage to lens when tilted to maximum; variable center height adjustment in three steps.



15SPK3  
19SPK3  
22SPK3  
116SPK3  
160SPK3  
204SPK3  
**RUBBER SPIKE FEET/STAINLESS STEEL**

Reversible rubber/metal spiked foot supplied with a dedicated fixing tool. The spike is made of a special hard anodised aluminum alloy extremely resistant to corrosion. Set of 3.



324  
**SURVEY PLATE ADAPTOR**

This adaptor is made of two pieces: a 5/8" bushing with a 3/8" female attachment to connect it to a tripod and a removable plate 124mm/4.9in diameter with a 5/8" male thread that should stay connected to the equipment. With the 324 it is possible to transform any Manfrotto tripod into a tripod compatible with the standard attachment interface system used in the survey and measuring industry.



15SCK3  
19SCK3  
22SCK3  
116SCK3  
160SCK3  
204SCK3  
**SUCTION CUP/RETRACTABLE SPIKE FEET**

A rubber suction cup foot with retractable stainless steel spike. The suction cup increases the suitable area of the foot of the monopod by almost 20 times, giving much greater stability when needed. The foot can be removed and replaced at will. Set of 3.



120DF  
**JOINT FOR ARMS**

Adapter 3/8" F-1/4" F allows using accessory arms 131DB and 131DDB as column extensions. Diameter: 60mm/23.6in.



120  
**TRIPOD ADAPTER**

Converts tripod head screw from 3/8" to 1/4". For models 800, 806, 809, 816 and 816/1.



273  
**SURVEY ADAPTOR**

Converts tripod head screw from 3/8" threads to 5/8".



236  
**SPIKED FOOT FOR MONOPOD**

Converts 679B, 680B and 681B series monopods rubber foot to a spiked foot.







# Accessories



131DB  
**ACCESSORY ARM**

Mounts on any column with 3/8" thread, this side arm allows positioning of two heads on a 90° perpendicular angle. For models 800, 806, 809, 816 and 816/1.

131D  
**ACCESSORY ARM**

Same as 131DB but silver.

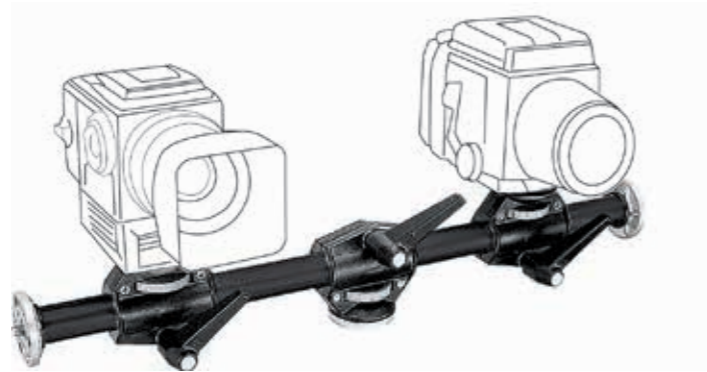

131DDB  
**ACCESSORY ARM FOR 4 HEADS**

Similar to the 131DB with the addition of two positional head mounts on the side arm allowing the possible mounting of four heads. For models 800, 806, 809, 816 and 816/1.



131TC  
**TABLE CENTER POST**

Geared column with clamp for table thickness from 18-38mm, for supporting a camera adjustable between 5cm/2in and 66cm/26in. Head not included.



183  
**MONITOR/PROJECTOR HOLDER**

Made of sturdy aluminum, this 25x35cm/10x13.8in platform can support up to 20kg/44.1lb. It is ideal as a projector or monitor stand.

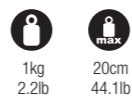

1kg 2.2lb  
20cm 44.1lb



MHMINIBALL  
**MINI ALUMINIUM BALL HEAD**

The small aluminium ball head features a universal female thread at the bottom, making it compatible with any support. Thanks to the universal 1/4" on top, it can hold any camera up to 1 kg/2.2lbs.

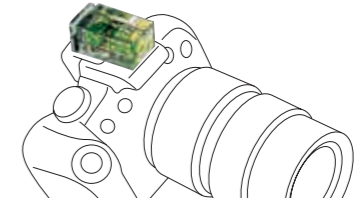

337  
**HOT SHOE TWO AXIS BUBBLE LEVEL**

The 337 is a double axis spirit level that mounts to the hot shoe of any standard 35mm SLR camera to help you achieve a finer degree of accuracy and consistency in panoramic photo sequences.

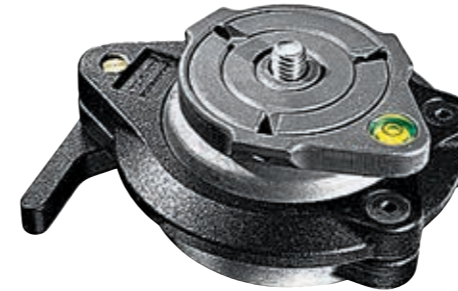

438  
**BALL CAMERA LEVELER**

The 438 is fitted between tripod and head and provides easy, fast leveling for tripods without built-in leveling mechanisms. Its range of movement is 10°.



5cm 2in  
0.6kg 1.4lb  
15kg 33.1lb



338  
**LEVELING BASE**

The 338 is fitted between tripod and head and is used in combination with tripods that don't have built-in leveling mechanisms. Its three adjustment dials enable the operator to make fine, finger tip adjustments up to +/- 5 degrees to ensure the camera is perfectly level. The dials also have locking rings to ensure stability once the right position is reached. A spirit level is built in for reference. The base has a 3/8" female tripod fitting and a 3/8" male head fitting.

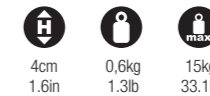

4cm 1.6in  
0.6kg 1.3lb  
15kg 33.1lb

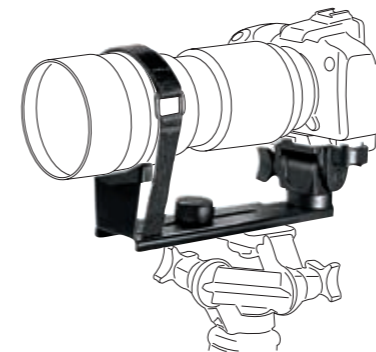

293  
**TELEPHOTO LENS SUPPORT**

Support for medium telephoto lens. The length of the bracket is adjustable to take different length lenses and different diameters by tilting the Tilt Head 234RC (included). Length from head to lens support adjustable from 200 to 295mm/78.7 to 116.1in. Attachments: 4x3/8" female and 3x1/4" female.



166  
**APRON SUPPORT**

Three compartments hang below the column supported by straps above the leg locks. Fits most Manfrotto tripods.



# Lighting Stands



5001B-1 **BLACK ALU NANO STAND**

Aluminium stand. 5 sections, 4 risers. Ø: 25, 22, 19, 16, 13mm. Solid flat legs 15x5mm. An ideal stand for kits due to its compact design.

- 49cm
- 190cm
- 48cm
- 100cm
- 0,93kg
- 1,5kg
- Type 19
- + Adapter Art. 015



5002BL **NANO PLUS STAND**

Aluminium stand, 5 Sections, 4 risers. Ø29.5, 26, Ø22.4, 19, 16 mm. Solid flat legs, 15cm x 6mm. Ideal for the travelling creative using slightly heavier portable lights and modifiers that are too heavy for the original Nano Stand.

- 52cm
- 207cm
- 52cm
- 92cm
- 1,35kg
- 4kg
- Type 19



1051BAC **BLACK ALU AIR CUSHIONED MINI COMPACT STAND**

Aluminium stand, air cushioned. 4 sections, 3 risers. Ø: 25, 22, 19, 16mm. Leg Ø: 19mm.



- 75cm
- 211cm
- 67cm
- 70cm
- 1kg
- 4kg
- Type 19
- 017
- + Adapter Art. 015



1052BAC **BLACK ALU AIR CUSHIONED COMPACT STAND**

Aluminium stand, air cushioned. 3 sections, 2 risers. Ø: 25, 22, 19mm. Leg Ø: 19mm.



- 101cm
- 237cm
- 86cm
- 109cm
- 1.2kg
- 5kg
- Type 25
- 017
- + Spigot Art. 015



MS0490A-1 **NANO POLE STAND**

Aluminum stand, compact stand with 5 sections, 4 risers. The column can be detached from the base and used as a boom.

- 49cm
- 195cm
- 49cm
- 100cm
- 1,07kg
- 1,5kg
- Type 19



MS0490C **CARBON NANOPOLE STAND**

5 Sections, 4 risers. Ø25, 22, 19, 16, 13mm. Solid flat legs, 15cm x 5mm. Detachable centre column for use as a boom. Ideal for the creative who is keen to travel light and portable whilst not compromising on the quality or stability of their lighting support.

- 50cm
- 197cm
- 50,8cm
- 100cm
- 0,75kg
- 1,5kg
- Type 19



1004BAC **BLACK ALU AIR CUSHIONED MASTER STAND**

Aluminium stand, air cushioned. 4 sections, 3 risers. Ø: 35, 30, 25, 20mm. Leg Ø: 22mm.



- 124cm
- 366cm
- 107cm
- 106cm
- 3kg
- 9kg
- Type 19
- 018
- + Adapter Art. 015



1005BAC **BLACK ALU AIR CUSHIONED RANKER STAND**

Aluminium stand, air cushioned. 3 sections, 2 risers. Ø: 35, 30, 25mm. Leg Ø: 22mm.



- 118cm
- 273cm
- 100cm
- 106cm
- 2kg
- 10kg
- Type 25
- 018
- + Spigot Art. 013



With the piling system portability is at the essence! Cling them together and save a lot of room in the studio or carry them in a compact case to easily bring them with you for outdoor shooting. The new baby is now able to stand up on its own even when it's closed.



# Boom Stand



## 420B BLACK ALU COMBI-BOOM STAND WITH SANDBAG

Aluminium stand. Supplied with sandbag counterweight (empty) for maximum stability and smoothness.  
4 sections, 3 risers. Ø: 35, 30, 25, 20mm. Leg Ø: 22mm.  
Min extension boom: 19cm Max extension boom: 191cm  
Maximum load at boom full extension: 2kg with counterweight.

- 131cm
- 392cm
- 113cm
- 109cm
- 2.7kg
- 9kg
- 0.9kg@392cm
- 018
- Type 25 + Spigot Art. 013

# Wind up Stand



## 087NWB BLACK STEEL WIND UP STAND

Black chrome steel stand with geared column.  
2 risers extend simultaneously at an elevation of 4.4cm per handle turn. Safety cable ensures simultaneous retrieval of all sections.  
3 sections, 2 risers. Ø: 55, 45, 38mm. Leg Ø: 30mm. 1 levelling leg.

- 167cm
- 370cm
- 181cm
- 128cm
- 21.4kg
- 30kg
- 30kg@370cm
- Type 14 104, 104G, 374-10



# Lighting Booms



## 425B BLACK MEGA BOOM (STAND NOT INCLUDED)

Largest boom in the range, remote control of pan, tilt and rotation of lamina plus geared telescopic extension. Combination of black zinc steel and black anodised aluminium tubes. Supplied with carrying bags.  
2 sections (Ø: 45, 55mm).  
Folded length: 220cm.  
Minimum extension from stand attachment: 50cm.  
Maximum extension from stand attachment: 320cm.  
\* Load: 6kg at maximum extension with 30kg of counterweight.  
30kg at minimum extension with 30kg of counterweight.

Suggested stands: Wind Up series.

- 15kg
- 6kg-30kg\*
- GC
- 16mm /28mm
- 28mm stand attachment



## 085BSL BLACK LIGHT BOOM 35 (STAND NOT INCLUDED)

Ø 35mm. 3 section boom arm complete with Pivoting Clamp 123, counterweight G-Peso 022, cable clips and locking key.  
Weight: 2.2kg, boom only.  
Dismantled length: 100cm.  
Assembled length: 280cm.  
Minimum extension from stand attachment: 10cm.  
Maximum extension from stand attachment: 250cm.  
Load: 6kg at maximum extension with 7kg of counterweight.

- 2.2kg
- 6kg
- Type 25 + Spigot Art. 013
- 28mm stand attachment



## 085BS BLACK LIGHT BOOM 35 (STAND INCLUDED)

Ø 35mm 3 sections boom arm complete with Pivoting Clamp 123, counterweight G-Peso 022, Cine Stand with casters, cable clips and locking key.  
Weight: 2.2kg, boom only.  
Dismantled length: 100cm.  
Assembled length: 280cm.  
Minimum extension from stand attachment: 10cm.  
Maximum extension from stand attachment: 250cm.  
Load: 6kg at maximum extension with 7kg of counterweight.

- 16.4kg
- 6kg
- Type 25 + Spigot Art.013
- 28mm stand attachment

## 025BSL BLACK SUPER BOOM (STAND NOT INCLUDED)

Ø 35mm. 1 section boom complete with Pivoting Clamp 123, counterweight G-Peso 022, cable clips.  
Weight: 4.1kg, boom only.  
Remote control of lighting movement: 270cm long.  
Minimum extension from stand attachment: 24cm.  
Maximum extension from stand attachment: 100cm.  
Load: 5kg at maximum extension with 7kg of counterweight.

- 4.1kg
- 5kg
- Type 17 + Rapidapter Art. 014-38
- 28mm stand attachment



## 025BS BLACK SUPER BOOM (STAND INCLUDED)

Ø 35mm 1 section boom arm complete with Pivoting Clamp 123, counterweight G-Peso 022, Cable Clips and Cine Stand 008 with casters.  
Weight: 4.1kg, boom only.  
Remote control of lighting movement: 270cm long.  
Minimum extension from stand attachment: 24cm.  
Maximum extension from stand attachment: 100cm.  
Load: 5kg at maximum extension with 7kg of counterweight.

- 21kg
- 5kg
- Type 25 + Rapidapter Art. 014-38
- 28mm stand attachment



# Autopole

Unique cantilever single action locking system exerts pressure to securely wedge the rubber suction cup ends in place. Cantilever system incorporates safety lock. Floor to ceiling, or wall to wall fixing for strong vertical or horizontal support of lighting.

### Loading limits

The following figures are valid for use with rigid floors and ceilings, and with the protection-cups mounted on the suction-cups.

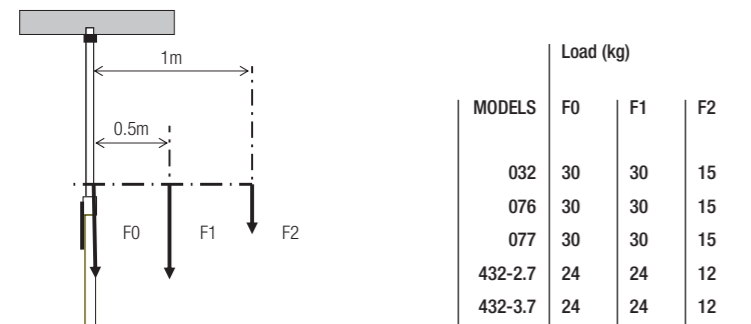

F0: maximum axial load - F1: maximum load with 0.5m arm - F2: maximum load with 1m arm

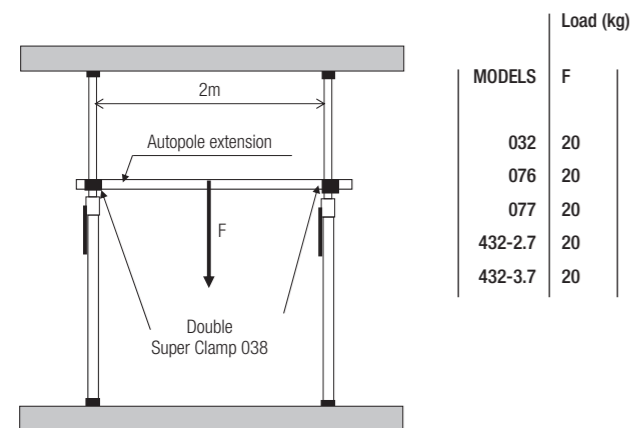

### 077 AUTOPOLE B

Extends from 100cm to 170cm. Pole Ø: 45mm and 40mm.



### 076 AUTOPOLE B

Extends from 150cm to 270cm. Pole Ø: 45mm and 40mm.



### 032 AUTOPOLE B

Extends from 210cm to 370cm. Pole Ø: 45mm and 40mm.



077



076



032

# Clamps

Manfrotto Super Clamp is the most versatile single piece of light grip gear. Frictionlined screw-operated jaws grip everything from 13mm to 55mm. Hexagonal socket with unique secondary safety lock system holds items in place even if the screw lock comes undone. Supplied with a wedge to square off the jaws for mounting to flat surfaces. This masterpiece of practicality and solidity is the most widely copied clamp in the world! Manfrotto Nano Clamp and Pico Clamp are the natural extension of the range; small but robust, they represent the ideal solution to grip loads to bars with diameter down to 8mm.

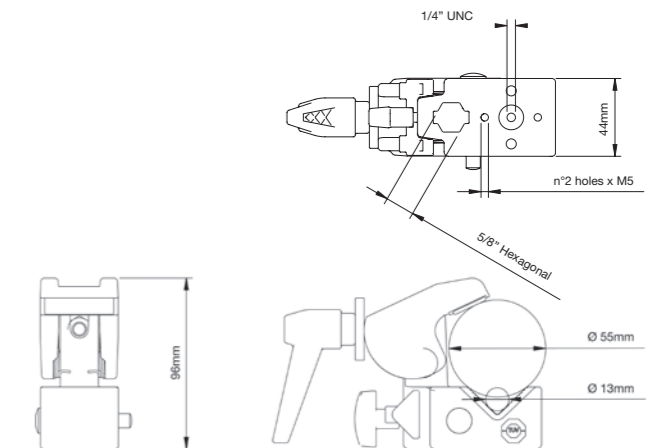

### 035 SUPER CLAMP



Ideal clamp for photographic application. Ergonomic lever to securely lock clamping position.



### 038 DOUBLE SUPER CLAMP

Set of two Super Clamps fastened together at fixed right angle to provide extra strength support for tubes or bars.



### MC1990A PICO CLAMP

Manfrotto "Pico Clamp" is an extra-small clamp with versatile use. It offers the possibility to safely attach the equipment to very thin bars, having a diameter from 8 to 15 mm.



### 635 QUICK ACTION SUPER CLAMP

The rapid action locking jaw has also been applied to the most well known clamp in the world, the original Super Clamp. These modifications allow us to keep its extreme versatility adding unrivaled speed in locking and unlocking. Supplied with wedge to allow the clamp to fit on flat surface.

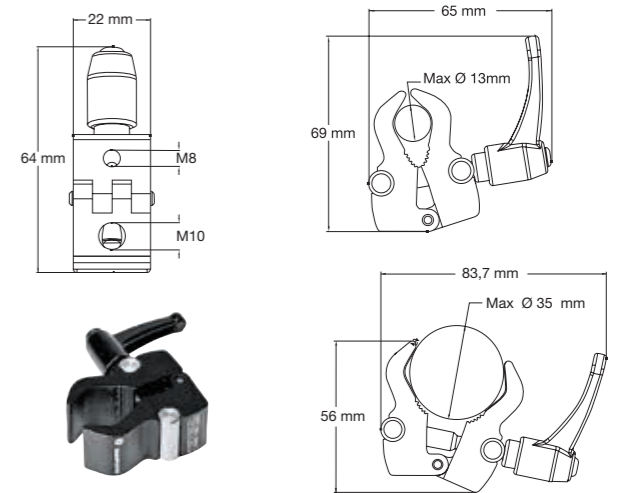

### 386B-1 NANO CLAMP

Its the new Manfrotto small size clamp. Its reduced size is the most important plus: the Nano Clamp is 4kg of payload in 110 grams of weight and the right size for any pocket.





### 013 SPIGOT ADAPTER

Universal 16mm spigot with double male thread 1/4" and 3/8".



0.07kg



### 036-38 LIGHTING STUD 3/8"

Plugs into Super Clamp 035 for lighting fixtures or connecting 2 Super Clamps 035 allowing them to rotate. 16mm stud with 3/8" male threads.



0.07kg



### 061 JOINING STUD

Connects 2 Super Clamp 035 with 6 step fixed rotation.



0.025kg



### 264 ROUNDED 16MM LIGHTING STUD M10

Rounded stud for stirrup's fixture for a rapid connection to a Super Clamp.



0.072kg



### 133B EXTENSION BAR

Used to fix 2 Super Clamps 035 at a distance of 15cm from each other. Length 16,5cm.



0.1kg



### 118 SHORT 16MM SPIGOT WITH 1/4" + 3/8" SCREW

Universal short 16mm spigot with double male thread 1/4" and 3/8".



0.04kg



### 036-14 LIGHTING STUD 1/4"

Same as 036-38 with 1/4" male threads.



0.07kg



### 061RA JOINING STUD RA

Connects 2 Super Clamps 035 at right angles or 45° steps.



0.025kg



### 174 HEXAGONAL 16MM LIGHTING STUD M10

Hexagonal Lighting stud for stirrup's fixture for a rapid connection to a Super Clamp.



0.062kg



### 036MR LIGHTING STUD MR

Plugs into Super Clamp 035 for lighting fixtures, Grip Heads or connect 2 Super Clamps 035 with 360° rotating capability.



0.048kg



### 119 ADAPTER SPIGOT 1/4" + 3/8" FEMALE THREADS

Universal short 16mm spigot with double female thread 1/4" and 3/8".



0.032kg



### 037 CAMERA STUD

Plugs into Super Clamp 035 socket. To mount cameras, directly or with a camera head. 3/8" and 1/4" threads.



0.04kg



### 066 DOUBLE FEMALE THREAD STUD

Plugs into Super Clamp 035 to provide either a 3/8" or 1/4" female thread fixing.



0.025kg



### 066BT STUD FOR STIRRUP

16mm stud with female thread M10. It has been specifically designed to mount it on a stirrup's fixture and easily connect it to a Super Clamp. Designed to be tightly lock with a wrench.



0.048kg



### C1000 DROP CEILING SCISSOR CLAMP

Drop ceiling scissor clamp



### 147 SHORT SPIGOT ADAPTER 1/4"-3/8"

Short spigot adapter 1/4" - 3/8".



0.05kg



### 042 EXTENSION ARM

Plugs into Super Clamp 035 socket. Length: 19.5cm.



0.21kg



8kg



Type 1



+ Spigot Art. 013



### 176 MINI "U" HOOKS

Set of two Mini "U" Hooks.



0.1kg



### 5039 OFFSET "U" HOOK

The unique Offset U Hook is the perfect partner for the Manfrotto Super Clamp, ideal for supporting power packs for lighting in the studio or on location.



0.16kg



15kg



16mm Hexagon Stud (Super Clamp AR)



### 125 SHORT SPIGOT ADAPTER 3/8"-3/8"

Short spigot adapter 3/8" - 3/8".



0.05kg



### 203 MINI EXTENSION ARM

Fits into Mini Clamp 171 socket. Length: 12cm.



0.15kg



5kg



12.5mm hole



### 039 "U" HOOKS

Set of two cross bar holders. Width: 40mm



0.16kg



# Arms



## 143N MAGIC ARM

Articulated arm, without accessories, with centre level to lock all 3 movements.

- 1,07kg
- 16mm with 1/4" female attachment
- 3kg
- 16mm with 3/8" female attachment



## 143A MAGIC ARM WITH CAMERA BRACKET

Magic Arm with camera bracket only.

- 1,07kg
- 16mm with 1/4" female attachment
- 3kg
- 16mm with 3/8" female attachment + Camera Bracket Art. 143BKT



## 244 VARIABLE FRICTION ARM WITH CAMERA BRACKET

Features as 143A, but a large locking knob takes the place of the cam-lever. Variable friction and locking of arm obtained by adjusting knob. Comes complete with Camera/Umbrella Bracket 143BKT only.

- 1,09kg
- 16mm with 1/4" female attachment
- 3kg
- 16mm with 3/8" female attachment + Camera Bracket Art.143BKT



## 244RC VARIABLE FRICTION ARM WITH QUICK RELEASE PLATE

Features as 143A, but a large locking knob takes the place of the cam lever. Variable friction and locking of arm obtained by adjusting knob. Supplied with a quick release camera plate with secondary safety lock based on the 200PL-14 system. Ideal for mounting a camera or a camcorder exactly at the angle you need it.

- 1,5 kg
- 16mm stud with 3/8" female attachment
- 4kg
- 1/4" thread quick release plate and 200PL-14 mount



## 143 MAGIC ARM KIT

Articulated arm with centre lever to lock all 3 movements. Length: 53cm. Supplied with: Camera/Umbrella Bracket 143BKT, Super Clamp 035, Backlite Base 003.

- 2,55kg
- 16mm with 1/4" female attachment
- 3kg
- 16mm with 3/8" female attachment + Camera Bracket Art. 143BKT



## 143RC MAGIC ARM WITH QUICK RELEASE PLATE

Your extra arm in the studio. One lever locks three pivot points. Supplied with a quick release camera plate with secondary safety lock based on the 200PL-14 system. Ideal for mounting a camera or a camcorder exactly at the angle you need it. Fits any 5/8"; female sockets, works especially well with 035 Super Clamp

- 1,5 kg
- 16mm stud with 3/8" female attachment
- 4kg
- 1/4" thread quick release plate and 200PL-14 mount



## 244N VARIABLE FRICTION ARM

Friction Arm with variable friction and locking of arm obtained by adjusting knob.

- 1,09kg
- 16mm with 1/4" female attachment
- 3kg
- 16mm with 3/8" female attachment





### 244MINI MINI FRICTON ARM

24cm friction arm with interchangeable 1/4" attachments and additional 3/8" adapter included.

3kg 0,44kg



### 244MICRO MICRO FRICTON ARM

15cm friction arm with interchangeable 1/4" attachments and additional 3/8" adapter included.

3kg 0,22kg



### 244MICRO-AR MICRO FRICTON ARM WITH ANTI ROTATION

15cm friction arm with interchangeable 3/8" Anti-rotation attachments and additional 3/8" adapter included. The Anti-rotation system is compatible with Manfrotto products: Digital Director and 386B-1 Nano Clamp.

3kg 0,24kg

### 244MICROKIT MICRO FRICTON ARM WITH NANO CLAMP

15cm friction arm with interchangeable 3/8" Anti-rotation attachment and 1/4" attachment and Nano Clamp included. The Anti-rotation system is compatible with Manfrotto products: Digital Director and 386B-1 Nano Clamp.

3kg 0,31kg



### 244MICRO-AA 244 MICRO ARM W/ ARRI STYLE AND ANTI SLIP ADPTS

15cm friction arm with interchangeable 3/8" Arri style Anti-Rotation Adapter and 1/4" Anti-Slip Adapter.

0,25kg 3kg



### 244ADPT14AS 1/4" ANTI SLIP ADAPT

1/4" Anti-Slip Adapter Accessory. Featuring a 1/4" thread and anti slip rubber texture upper. Compatible with: 244Mini, 244Micro, 244Micro-AR, 244MICRO-AA, 244MicroKit.



### 244ADPT58 5/8" ADAPTERS

Two 5/8" adapters accessories compatible with the following friction arms: 244Mini, 244Micro, 244Micro-AR, 244MicroKit, 244MICRO-AA.



### 244ADPT3814 3/8" AND 1/4" ADAPTERS

3/8" and 1/4" adapters accessories compatible with the following friction arms: 244Mini, 244Micro, 244Micro-AR, 244MicroKit, 244MICRO-AA.



### 244ADPT38AA 3/8" ARRI STYLE ANTI-ROTATION ADAPT

3/8" Arri style Anti-Rotation Adapter Accessory. Featuring a reversible plate to allow use of the thread without the two locating pins. Compatible with: 244Mini, 244Micro, 244Micro-AR, 244MICRO-AA, 244MicroKit.



### 244ADPT38AR 3/8" ANTI-ROTATION ADAPTER

Anti-rotation adapter accessory compatible with the following friction arms: 244Mini, 244Micro, 244Micro-AR, 244MicroKit, 244MICRO-AA. The Anti-rotation system is compatible with Manfrotto products: Digital Director and 386B-1 Nano Clamp.



### 244ADPT-HS HOT-SHOE ADAPTER

Hot-shoe adapter accessory compatible with the following friction arms: 244Mini, 244Micro, 244Micro-AR, 244MicroKit, 244MICRO-AA.

## SINGLE ARTICULATED ARMS: 2 & 3 SECTIONS

A more versatile version with telescopic features that make this product even more compact than before. Two available versions – at two and three sections- in order to ensure broad range of length, from 605 to 850mm.

| Code    | Sections | Top attachment  | Bottom attachment  | Max length | Max load at full extension | Weight |
|---------|----------|---|--|------------|----------------------------|--------|
| 196AB-2 | 2        | 16mm spigot with 3/8" light attachment                | 16mm spigot (compatible with Super Clamp) with 1/4" thread | 605mm      | 1.5kg                      | 0.4kg  |
| 196AB-3 | 3        | 16mm spigot with 3/8" light attachment                | 16mm spigot (compatible with Super Clamp) with 1/4" thread | 850mm      | 1kg                        | 0.5kg  |
| 196B-2  | 2        | camera bracket with 16mm spigot and camera attachment | 16mm spigot (compatible with Super Clamp) with 1/4" thread | 605mm      | 1.5kg                      | 0.53kg |
| 196B-3  | 3        | camera bracket with 16mm spigot and camera attachment | 16mm spigot (compatible with Super Clamp) with 1/4" thread | 850mm      | 1kg                        | 0.63kg |



## DOUBLE ARTICULATED ARMS: 2 & 3 SECTIONS

Excellent performance: robustness, lightness and versatility... these are the features of the new double articulated arm range. The 396 family has been developed to provide greater robustness than the 196 range and to support heavier loads (up to 5kg), though keeping versatility thanks to its extendable sliding arm system (extends up to 860mm), further enhanced by its quick lock system. The new bottom attachment adds to the strength and versatility of the 396, with a spigot that combines both a hexagonal part (for anti-rotation fixing to the Super Clamp system) and a universal adapter section (for fitting to a wide range of stands, clamps and accessories).

| Code    | Sections | Top attachment  | Bottom attachment                               | Max length | Max load at full extensions | Weight |
|---------|----------|---|---|------------|-----------------------------|--------|
| 396AB-2 | 2        | 16mm spigot with 3/8" light attachment                | Double-anchored 16mm hexagonal/universal spigot | 625mm      | 5kg                         | 0.5kg  |
| 396AB-3 | 3        | 16mm spigot with 3/8" light attachment                | Double-anchored 16mm hexagonal/universal spigot | 860mm      | 4.5kg                       | 0.79kg |
| 396B-2  | 2        | camera bracket with 16mm spigot and camera attachment | Double-anchored 16mm hexagonal/universal spigot | 625mm      | 5kg                         | 0.64kg |
| 396B-3  | 3        | camera bracket with 16mm spigot and camera attachment | Double-anchored 16mm hexagonal/universal spigot | 860mm      | 4.5kg                       | 0.9kg  |





# Pro Scrim

The Pro Scrim All In Ones are a collection of four lightweight professional light control kits that include all of the essential components required for creative image makers to take control of their lighting set up by bouncing, diffusing and flagging the light source. Included is a lightweight frame, textile covers, grip heads, ears and a carry case. Pro Scrim is available in four different sizes; Small 1.1m x 1.1m (3.6 x 3.6ft), Medium 1.1m x 2m (3.6 x 6.5ft), Large 2m x 2m (6.5 x 6.5ft) and Extra Large 2.9m x 2.9m (9.5ft) all of which effortlessly fold down into their own rigid carry case with an impressive compact folded size of just 102 x 24 x 19cm (40.1 x 9.4 x 7.4in) making it extremely transportable.



**MLLC1101K**  
**PRO SCRIM ALL IN ONE KIT 1.1X1.1M SMALL**

1x lightweight frame, 3x textile covers; (black, double-sided silver/white bounce and 1.25 stop diffuser), 1x grip head and carry case. Dimensions in case: Height 240cm, Width 190cm, Depth 1025cm. Weight in case 5.75kg.



**MLLC1201K**  
**PRO SCRIM ALL IN ONE KIT 1.1X2M MEDIUM**

1x lightweight frame, 3x textile covers; (black, double-sided silver/white bounce and 1.25 stop diffuser), 2x grip heads, 2x ears and carry case. Dimensions in case: Height 240cm, Width 190cm, Depth 1025cm. Weight in bag 7.45kg.



**MLLC2201K**  
**PRO SCRIM ALL IN ONE KIT 2X2M LARGE**

1x lightweight frame, 3x textile covers; (black, double-sided silver/white bounce and 1.25 stop diffuser), 2x grip heads, 2x ears and carry case. Dimensions in case: Height 240cm, Width 190cm, Depth 1025cm. Weight in bag 9.9kg.



**MLLC3301K**  
**PRO SCRIM ALL IN ONE KIT 2.9X2.9M EXTRA LARGE**

1x lightweight frame, 2x textile covers; (black and 1.25 stop diffuser), 2x grip heads, 2x ears and carry case. Dimensions in case: Height 240cm, Width 190cm, Depth 1025cm. Weight in bag 11.4kg.



# Chroma Key FX

The Chroma Key FX Background is Manfrotto's all in one portable Chroma Key background solution, tailored to most demanding content creators, videographers and cinematographers working on the move.

At an impressive size of 4.2m (13'7") wide and 3m (9'8") tall, the Manfrotto Chroma Key FX background is the largest reusable all in one Chroma Key background kit available. This large working area makes it ideal for use when shooting wide and low camera angles, as well as moving subjects that would otherwise prove unachievable with a smaller surface. The ability to reuse this kit time and time again make this kit an invaluable asset with a return on investment after just one or two uses when compared to a non-re-usable build.



**MLBG4301KG MANFROTTO CHROMA KEY FX 4X2.9M BACKGROUND KIT GREEN**

Includes three ultra-fast assembly aluminium frames, one clip on Chroma Key Green cover, four hinge clips, two tensioning bars and one soft carrying bag. Dimensions in bag: Height 30cm, Width 103cm, Depth 30cm. Weight in bag 9.8kg.



**MLBG4301KB MANFROTTO CHROMA KEY FX 4X2.9M BACKGROUND KIT BLUE**

Includes three ultra-fast assembly aluminium frames, one clip on Chroma Key Blue cover, four hinge clips, two tensioning bars and one soft carrying bag. Dimensions in bag: Height 30cm, Width 103cm, Depth 30cm. Weight in bag 9.8kg.



**MLBG4301CG MANFROTTO CHROMA KEY FX 4X2.9M BACKGROUND COVER GREEN**



**MLBG4301CB MANFROTTO CHROMA KEY FX 4X2.9M BACKGROUND COVER BLUE**





# Pro Light Reloader

The new Manfrotto Pro Light Reloader Camera Roller Bags for DSLRs and camcorders are the ideal carrying solution for travelling photographers and videographers. Manufactured and designed specifically for travellers, they fit carry-on sizes\* and are both secure and shock absorbing. Composed of six trolleys, the collection features unprecedented lightness and protection. The perfect on location carrying solutions.



## MB PL-RL-A55 PRO LIGHT RELOADER AIR-55

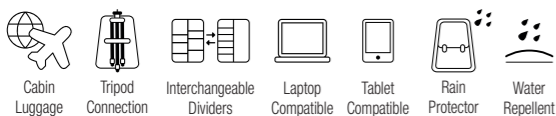

The new Pro Light Reloader Air-55 Roller Bag for DSLRs and modular camcorder is designed for professional travelling photographers and videographers. Manufactured and designed specifically for travellers, it fits international airline carry-on sizes. Externally, Reloader Air-55 is made of Double Ripstop and Ballistic Nylon featuring upgraded corners protection and additional protection trims; internally, it features EVA moulded trays to ensure lightweight and protection. This roller bag can accommodate a pro DSLR attached with a 400 mm f/2.8 lens, a second DSLR body and up to 3-4 lenses as well as being able to comfortably fit a modular camcorder as a Canon C100 Mark II with lenses and accessories. The roller bag can be tailored to suit the equipment, with 14 protective dividers and 5 CPS dividers that can be easily adjusted. In addition, it is equipped with 2 internal panel see-through pockets for organize all small camera accessories, cables, memory cards etc. The Air-55 is equipped with a big easy-access front pocket for your 17" laptop and an additional second front pocket for documents and personal items.

### Key benefits:

- Fits a Pro DSLR with 400/2.8 plus 3 lenses
- Outer made from Double Ripstop and Ballistic Nylon
- Strong, lightweight construction for lasting performance
- It fits international carry-on sizes\*
- 4-in-1 lock system, to close all pockets through TSA

External Dimensions: 35.5x23x55 cm / 14x9x21.6 in  
 Internal Dimensions: 32x18x47 cm / 12.6x7x18.5 in  
 Weight: 3,7 kg / 8.1 lbs

\*Always check with your airline before flying for their current carry-on requirements. Be aware that overloading the bag will cause it to expand.



## MB PL-RL-A50 PRO LIGHT RELOADER AIR-50



The new Pro Light Reloader Air-50 Roller Bag for DSLRs is designed for professional travelling photographers that are always on-the-go. Manufactured and designed specifically for travellers, it fits strictest airline carry-on sizes\*. Externally, Air-50 is made of Double Ripstop and Ballistic Nylon featuring upgraded corners protection and additional protection trims; internally, it features with EVA moulded trays to ensure lightweight and protection. This roller bag can accommodate a DSLR such as a Canon 5D Mark IV with a 70-200 mm f/2.8 lens attached, a second DSLR body and up to 3-4 lenses as well as being able to comfortably fit a complete full frame CSC kit. The roller bag can be tailored to suit the equipment, with 12 protective dividers + 2 CPS dividers that can be easily adjusted. In addition, it is equipped with 2 internal panel see-through pockets for organize all small camera accessories, cables, memory cards etc. The Air-55 is equipped with a big easy-access front pocket for your 15" laptop and an additional second front pocket for documents and personal items.

### Key benefits:

- Fits a 2 DSLR with 70-200 mm f/2.8 lens plus 3-4 lenses
- Outer made from Double Ripstop and Ballistic Nylon
- Strong, lightweight construction for lasting performance
- It fits domestic carry-on sizes\*
- Fixed TSA lock for extra security

External Dimensions: 35.5x20x50 cm / 14x7.9x19.6 in  
 Internal Dimensions: 30x16x43 cm / 11.8x6.3x16.9 in  
 Weight: 3,2 kg / 7 lbs



## MB PL-RL-S55 PRO LIGHT RELOADER SPIN-55

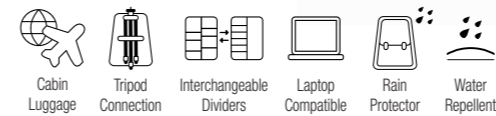

The new Pro Light Reloader Spin-55 Camera Roller Bag for DSLRs and full frame mirrorless is designed for professional travelling photographers. Manufactured and designed specifically for travellers, it fits international carry-on sizes\*. This brand-new Pro Light roller bag is the hardside trolley of the collection: externally, it is made of polycarbonate material and internally of EVA moulded trays to ensure lightweight and protection. It features 4 spinner double wheels to help carrying heavy gear and a front fast access for 15" laptop, accessories or a secondary access for photo gear. This roller bag comes with an internal organized pouch with CPS dividers for maximum flexibility of internal configuration that can be used as photo compartment or removed to use Spin-55 as normal travel luggage. It is equipped also with inner cross ribbons to hold personal items when using it as everyday suitcase. This roller bag can accommodate not only your DSLR such as a Canon 5D Mark IV attached with a 70-200 mm f/2.8 lens, a second DSLR body and up to 3-4 lenses as well as being able to comfortably fit a full frame CSC as a Sony a9 with additional lenses and a DJI Mavic Pro combo kit. Tailor your bag to suit your own equipment, with 12 protective dividers + 2 CPS internal dividers that can be easily adjusted depending what you've got going on that day. In addition it is equipped with 2 internal panel see-through pockets for organize all small camera accessories, cables, memory cards etc.

### Key benefits:

- Both photographic rolling case and travel suitcase
- Polycarbonate external shell for lightness and durability
- 4 spinner double wheels for easier carrying
- Front fast access to internal compartment
- Fixed TSA lock for extra security

External Dimensions: 35.5x22x55 cm / 14x8.6x21.6 in  
 Internal Dimensions: 32x16x46 cm / 12.6x6.3x18.1 in  
 Weight: 3,7 kg / 8.1 lbs

\*Always check with your airline before flying for their current carry-on requirements. Be aware that overloading the bag will cause it to expand.



### MB PL-RL-H55 PRO LIGHT RELOADER SWITCH-55

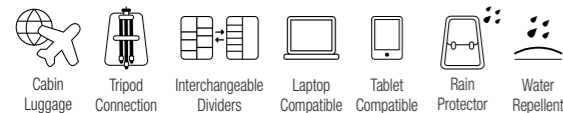

The new Pro Light Reloader Switch-55 Camera Roller Bag for DSLRs and modular camcorder is manufactured and designed for professional photographers and videographers that are always on the go and it fits international carry-on sizes. Externally, Switch-55 is made of Double Ripstop and Ballistic Nylon featuring upgraded corners protection and additional protection trims; internally, it features EVA moulded trays to ensure lightweight and protection. Versatility is the key benefit of Switch-55: you can convert the roller bag into a backpack when needed, easily pulling out two hideaway padded shoulder straps positioned on front side pocket. This roller bag can accommodate not only a pro DSLR attached with a 400 mm f/2.8 lens, a second DSLR body and up to 3-4 lenses as well as being able to comfortably fit a modular camcorder as a Canon C100 Mark II with lenses and accessories. The roller bag can be tailored to suit the equipment with 14 protective dividers + 2 CPS dividers that can be easily adjusted. In addition it is equipped with 2 internal panel see-through pockets for organize all small camera accessories, cables, memory cards etc. The Switch-55 is equipped with a big easy-access front pocket for your 17" laptop and an additional second front pocket for documents and personal items.

#### Key benefits:

- 2-in-1 roller bag plus camera backpack
- Fits a 2 DSLR body and up to 4/5 lenses
- Outer made from Double Ripstop and Ballistic Nylon
- Strong, lightweight construction for lasting performance
- It fits international carry-on sizes\*

External Dimensions: 35.5x23x55 cm / 14x9x21.6 in  
Internal Dimensions: 32x18x47 cm / 12.6x7x18.5 in  
Weight: 4 kg / 8.8 lbs



### MB PL-RL-TH55 / MB PL-RL-TL55 PRO LIGHT RELOADER TOUGH H-55 AND L-55

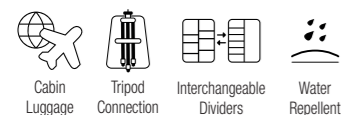

Carry and protect your DSLR or modular camcorder gear with the New Pro Light Reloader Tough TH-55 and TL55. These cases are made in Italy with heavy-duty materials, based on lightweight and military standard, with an original Manfrotto style. Manufactured and designed for travellers who don't want to compromise between safety and portability. New Pro Light Reloader Tough family has an internal removable camera organization unit with Manfrotto CPS divider and it is provided also with 2 stage retractable trolley system. Pro Light Reloader Tough TH-55 with high hood fits international carry-on sizes\* and holds your DSLR such as a Canon 5D Mark IV with a 400/f2.8 lens attached, a second camera body and 3-4 additional lenses depending on sizes while Tough LH-55 with low hood fits most Airplane companies\* carry-on sizes and holds your DSLR with a 70/200 mm f/2.8 lens attached, a second camera body and 4-5 additional lenses depending on sizes. An external front tripod holder allow you to carry your favourite big-size tripod, through proper metal pins positioned on front.

#### Key benefits:

- Rigid and robust made in Italy photographic hard-case
- Based on lightweight and military standard materials
- Comes with a tripod holder system
- Safe release system latches for security
- Available in two version TL-55 low hood and TH-55 high hood

#### MB PL-RL-TH55

External Dimensions: 35x22,5x55 cm / 13.7x8.8x21.6 in  
Internal Dimensions: 26x17x50 cm / 10.2x6.6x19.6 in  
Weight: 4,0 kg / 8.8 lbs

#### MB PL-RL-TL55

External Dimensions: 35x20x55 cm / 13.7x7.8x21.6 in  
Internal Dimensions: 26x14x50 cm / 10.2x5.5x19.6 in  
Weight: 4,4 kg / 9.7 lbs

\*Always check with your airline before flying for their current carry-on requirements. Be aware that overloading the bag will cause it to exp

# Pro Light Collection



### MB PL-CB-BA PRO LIGHT CINEMATIC CAMCORDER BACKPACK BALANCE



Professional videographer's bag designed for a one-man-band & run and gunner who need to carry everything required to do their job in a single bag. This carry-on pack is built to hold and protect a VDSLR or mirrorless with several lenses and DJI Ronin M/MX fully set up thanks to its signature Camera Protection System dividers. Holds a device up to 17".

#### Key benefits:

- Holds DSLR or mirrorless with DJI Ronin M/MX in a carry-on size
- Holds all gimbal accessories & video monopod
- Strong, lightweight construction designed for the long haul
- Tuck-away strap for carrying video rig and supports
- Handy side access for quick lens changes

External Dimensions: 37x23x59 cm / 14.5x9.0x23.2 in  
Internal Dimensions: 33.5x21.5x52 cm / 13.1x8.4x20.4 in  
Weight: 2,5 kg / 5.5 lbs



### MB PL-CB-EX PRO LIGHT CINEMATIC CAMCORDER BACKPACK EXPAND



Professional videographer's bag designed for a one-man-band & run and gunner who need to carry everything required to do their job in a single bag. This carry-on\* pack is built to hold and protect a modular camcorder with up to 70-200/2.8 mm lens attached and up to 10 lenses, video accessories or camera bodies. Thanks to its expandable front, this pack can be made bigger to fit a camcorder with its handle assembled. With a simple gesture, the bag can be expanded and its configuration changed to a handy working mode. When the backpack needs to be as compact as possible for travel, the front panel can easily be made smaller to fit carry-on travel bag size criteria. Holds a laptop up to 17".

#### Key benefits:

- Expandable front for modular camcorder with assembled handle
- Shock Absorbing Divider System for impact protection
- Strong, lightweight construction designed for the long haul
- Tuck-away strap for carrying video rig and supports
- Handy side access for quick lens changes in the back panel

External Dimensions: 36.5x23x59 cm / 14.3x9.0x23.2 in  
Internal Dimensions: 33x21.5x52 cm / 12.9x8.4x20.4 in  
Weight: 2,6 kg / 5.7 lbs





# Pro Light Collection



MB PL-CC-191N **PRO LIGHT CAMCORDER CASE 191N FOR PXW-FS5 II, XF205, HDV, VDSLR**

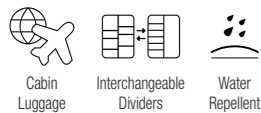

Perfect carrying & protecting solution for modular camera (e.g. SONY PXW-FS5 II, Canon EOS C70, disassembled Canon EOS C500 Mark II), classic HDV camera (e.g. SONY PXW-Z90, Canon XF205) or Video DSLR (e.g. Canon EOS-1D X Mark III, 5D mark IV) or video camera (e.g. BlackmagicMicro Studio camera 4K, Panasonic LUMIX GH5).

External Dimensions: 23x41x29 cm / 9x15x11.4 in  
Internal Dimensions: 20x39x23 cm / 7.8x15.3x9 in  
Weight: 1,3 cm / 2.86 lbs

**Key benefits:**

- Compact video camera case for professional videographers
- Perfect bag for SONY PXW-FS5 II or disassembled Canon EOS C500 MKII
- Absorb shock & protect the camera by Camera Protection System (CPS)
- Super wide dual-zipper opening ensures easy access



MB PL-CC-192N **PRO LIGHT CAMCORDER CASE 192N FOR C100, C300, C500 MKII, AG-DVX200**

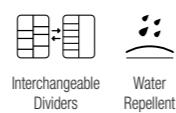

Perfect carrying & protecting solution for modular camcorder (e.g. Canon C100 Mark II/C300 Mark II/C500 Mark II, Blackmagic URSA Mini Pro) or classic HDV camera (e.g. Sony PXW-Z280, Panasonic AGDVX200 4K) or Video DSLR with top handle installed (e.g. Canon EOS-1D X Mark III, 5D mark IV).

External Dimensions: 28x50.5x36 cm / 11x19.9x14 in  
Internal Dimensions: 24x48.5x30 cm / 9.4x19x11.8 in  
Weight: 2,1 cm / 4.6 lbs

**Key benefits:**

- Video camera case for professional videographers
- Perfect bag for Canon C100 Mark II/C300 Mark II/C500 Mark II, or Panasonic AG-DVX200 4K
- Protect the camera by Camera Protection System (CPS) & metal frame
- Expandable back pocket for bigger accessories



MB PL-CC-193N **PRO LIGHT CAMCORDER CASE 193N FOR PXW-Z280, HDV**

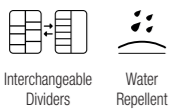

Perfect carrying & protecting solution for latest modular camcorder (e.g. SONY PXW-FS7 Mark II with handle detached) or HDV camera (e.g. Sony PXW-Z280, Panasonic AG-UX180 4K) or Video DSLR (e.g. Canon EOS-1D X Mark III, 5D mark IV).

External Dimensions: 29x53.5x33 cm / 11.4x21x13 in  
Internal Dimensions: 23x51.5x27 cm / 9x20.2x10.6 in  
Weight: 2,1 cm / 4.6 lbs

**Key benefits:**

- Video camera case for professional videographers
- Perfect bag for HDV cameras like SONY PXW-Z280, Panasonic AG-UX180 4K
- Protect the camera by Camera Protection System (CPS) & metal frame
- Extra room for bigger accessories offered by expandable back pocket
- Super wide dual-zipper opening ensures easy access



MB PL-CC-195N **PRO LIGHT CAMCORDER CASE 195N FOR PXW-FS7 MKII, ENG CAMERA, VDSLR**

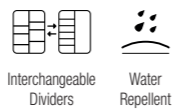

Perfect carrying & protecting solution for latest modular camcorder (e.g. SONY PXW-FS7 Mark II) or shoulder mount ENG camera or Video DSLR with rig (e.g. Canon EOS-1D X Mark III, 5D Mark IV).

External Dimensions: 37x58.5x36 cm / 14.5x23x14 in  
Internal Dimensions: 30x56.5x30 cm / 11.8x22.2x11.8 in  
Weight: 2,9 kg / 6.4 lbs

**Key benefits:**

- Video camera case for professional videographers
- Perfect bag for SONY PXW-FS7 MKII or ENG camera or rigged VDSLR
- Protect the camera by Camera Protection System (CPS) & metal frame
- Extra room for bigger accessories



MB PL-CC-197 **PRO LIGHT CAMCORDER CASE FOR PDW-Z750, PXW-X400**



CC-197 PL video case is an optimal professional solution for protecting, carrying and working with large camcorders or DSLRs used with a video rigs.

**Key benefits:**

- Made from water-repellent fabric
- Camcorder case with shock absorption and vibration reduction
- Protect the camera by Camera Protection System (CPS) & metal frame

External Dimensions: 70x36x34 cm / 27.5x14.1x13.3 in  
Internal Dimensions: 66x29x26 cm / 25.9x11.4x10.2 in  
Weight: 2,54 kg / 5.6 lbs

## Rolling Organisers for lighting



MB PL-LW-88W-2 **ROLLING ORGANIZER**

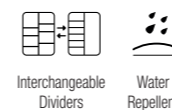

The MB PL-LW-88W-2 is a medium-sized rolling organizer, built to provide the most lightweight high-protection storage and transportation solution for lighting gear.  
External Dimensions: 40x27x84 cm / 15.7x10.6x33 in  
Internal Dimensions: 36x21x77 cm / 14.1x8.2x30.3 in  
Weight: 5 kg / 11 lbs



MB PL-LW-97W-2 **ROLLING ORGANIZER**

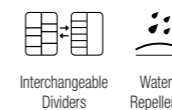

The MB PL-LW-97W-2 is a large rolling organizer built to provide the most lightweight high-protection storage and transportation solution for lighting gear.  
External Dimensions: 44x30x100 cm / 17.3x11.8x39.3 in  
Internal Dimensions: 40x24x94 cm / 15.7x9.4x37 in  
Weight: 5,8 kg / 12.7 lbs



MB PL-LW-99W-2 **ROLLING ORGANIZER**

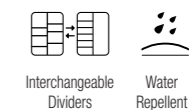

The MB PL-LW-99W-2 is an extra-large rolling organizer built to provide the most lightweight high-protection storage and transportation solution for lighting gear.  
External Dimensions: 45x30x114 cm / 17.7x11.8x44.8 in  
Internal Dimensions: 40x24x108 cm / 15.7x9.4x42.5 in  
Weight: 6,4 kg / 14.1 lbs



# Pro Light Collection



MB PL-3N1-26  
**PRO LIGHT CAMERA BACKPACK 3N1-26 FOR DSLR/CSC/C100**

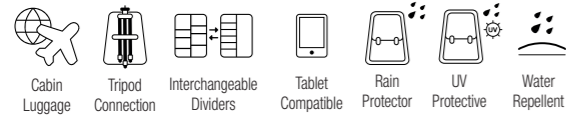

A multi-purpose professional camera backpack that allows 3 different ways to wear and carry different type of gears. The pack can be dedicated 100% to camera gear or reserve the top compartment for personal belongings even though it is now padded too. By smartly rearranging the dividers inside, you can choose to store photo and video gear in it.



MB PL-3N1-36  
**PRO LIGHT CAMERA BACKPACK 3N1-36 FOR DSLR/C100/DJI PHANTOM**



A multi-purpose professional camera backpack that allows 3 different ways to wear and carry 3 different type of gears. The pack can be dedicated 100% to camera gear or reserve the top compartment for personal belongings even though it is now padded too. By smartly rearranging the dividers inside, you can choose to store photo gear, video gear or even a drone in it.



MB PL-BP-R-110  
**PRO LIGHT REDBEE-110 FOR CSC**



Pro Light RedBee-110 can safely carry 2 Premium CSC bodies and a 70/200 mm f/2.8 lens attached and additional lenses, or a premium CSC, a foldable drone. Pro Light RedBee camera backpacks presents a safe rear access to the camera gear, with flexible dividers and a zippered mesh system to keep camera kit separate from other items e.g. 13" laptop and tablet, rain cover. The new Pro Light RedBee-110 features enhanced external look and a new front pocket, a zipper locker to safely hold all gear, and a side tripod connection. There are also a side access point for those who want to grab their camera and capture moments on the go, and a quick access to the gear from the top of the bag.



MB PL-BP-R-310  
**PRO LIGHT REDBEE-310 FOR DSLR/CAMCORDER**

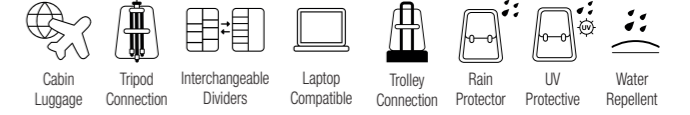

Pro Light RedBee-310 smart design allows to safely carry a 400 mm f/2.8 lens attached to a Pro DSLR and one more DSLR body with 2-3 additional lenses; or a modular video camera and lenses. RedBee-310 camera backpack presents a safe rear access to the camera gear, with flexible dividers and a zippered mesh system to keep camera kit separate from other items e.g. 15" laptop and tablet, rain cover. The new Pro Light RedBee-310 features enhanced external look and a new front pocket, a zipper locker to safely hold all gear, and a side tripod connection. There are also two side access points for those who want to grab their camera and capture moments on the go, and a quick access to the gear from the top of the bag.



MB PL-B-130  
**PRO LIGHT CAMERA BACKPACK BUMBLEBEE-130 FOR DSLR/CSC**

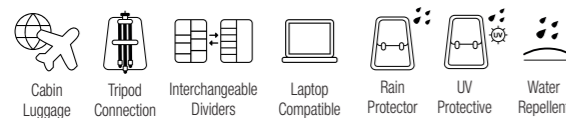

Manfrotto's Pro Light Bumblebee-130 PL camera backpack is a professional camera bag designed for outdoor shooters who are always on the move. This carry-on pack is built to keep professional gear protected while providing long-wearing comfort. Its signature design Camera Protection System dividers safeguard a DSLR body with 70-200/2.8 attached plus 8 lenses, or an unattached 400/2.8 with 3 lenses, or a compact professional camcorder with accessories. The center section can hold an unattached gripped DSLR body. The independent, "checkpoint-friendly" laptop pocket holds a 15" laptop.



MB PL-B-230  
**PRO LIGHT CAMERA BACKPACK BUMBLEBEE-230 FOR DSLR/CAMCORDER**



Manfrotto's Pro Light Bumblebee-230 PL camera backpack is a professional camera bag designed for outdoor shooters who are always on the move. This carry-on pack is built to keep professional gear protected while providing long-wearing comfort. Its signature design Camera Protection System dividers safeguard a gripped DSLR body with 70-200/2.8 attached plus 10 lenses, or an attached 400/2.8 with 5 lenses, or a professional camcorder with accessories. The independent, "checkpoint-friendly" laptop pocket holds a 17" laptop.



MB PL-BM-10  
**PRO LIGHT CAMERA MESSENGER BUMBLEBEE M-10 FOR DSLR/CSC**



Manfrotto's Pro Light Bumblebee M-10 PL camera messenger is a professional camera bag designed for outdoor shooters who are always on the move. This super-roomy, slim profile bag is built to keep a professional camera kit plus a 13" laptop secure while providing long-wearing comfort. Its signature design Camera Protection System dividers safeguard a CSC/DSLR body with 24-70/2.8 lens attached plus 2 lenses (including 70-200/2.8), a handheld gimbal and lots of accessories. These can be taken out quickly through the top zip opening. The specially designed XtraSecure strap keeps the moving part of the handheld gimbal steady. The bag also holds a gripped DSLR kit if you are not carrying a laptop.



MB PL-BM-30  
**PRO LIGHT CAMERA MESSENGER BUMBLEBEE M-30 FOR DSLR**

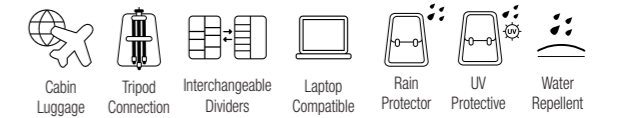

Manfrotto's Pro Light Bumblebee M-30 PL camera messenger is a professional camera bag designed for outdoor shooters who are always on the move. This super-roomy, slim profile bag is built to keep a professional camera kit plus a 15" laptop protected while providing long-wearing comfort. Its signature design Camera Protection System dividers safeguard a DSLR body with 70-200/2.8 lens attached plus 3 lenses, a handheld gimbal and lots of accessories. These can be taken out quickly through the top zip opening. The specially designed XtraSecure strap keeps the moving part of the handheld gimbal steady. The bag also holds a gripped DSLR kit if you are not carrying a laptop.



# Lino Collection



MB MBAG120PN MB MBAG100PN MB MBAG90PN MB MBAG80PN MB MBAG75PN

## MB MBAG120PN 120CM PADDED TRIPOD BAG

The largest bag in the range, the MB MBAG120PN is padded to protect your equipment and has the following features:

- Asymmetric tapered shape allows you to store the tripod with the head attached.
- Tripod legs fit comfortably in the narrower end and extra space is allowed for the larger volume of the head at the wider end. Diameter 23cm (9.1in).
- Zipper extends down the length of the bag, but also fully opens the top end of the bag.
- Thermoform padding holds the tripod in place in the bag and protects it, especially the head, during transport.
- Inner pocket holds accessories (such as video head pan bars).
- Innovative design and style; ballistic nylon, zips and other materials used are of top quality.
- Can be hand-carried horizontally by the side handle, vertically by the end handle (also useful for storage), or shoulder-carried using the included strap.
- Able to accommodate a tripod with a head up to 115 cm long

## MB MBAG100PN 100CM PADDED TRIPOD BAG

Same design of MB MBAG120PN. Able to accommodate a tripod with a head up to 95 cm long.

## MB MBAG90PN 90CM PADDED TRIPOD BAG

Same design of MB MBAG120PN. Able to accommodate a tripod with a head up to 85 cm long.

## MB MBAG80PN 80CM PADDED TRIPOD BAG

Same design of MB MBAG120PN. Able to accommodate a tripod with a head up to 79 cm long.

## MB MBAG75PN 75CM PADDED TRIPOD BAG

Same design of MB MBAG120PN. Able to accommodate a tripod with a head up to 75 cm long.



## MB MBAG100PNHD 100CM HD PADDED TRIPOD BAG

Long-lasting and ergonomically designed to carry heavy loads. The MBAG100PN HD padded tripod bag is perfect for storing tripods with heads up to 95cm long. Ideal for 475 tripod with 400 or 405 head. With its clever asymmetrical design, adjustable shoulder strap, and two carrying handles, you can carry it with ease. Thanks to its high-quality Thermoform padded interior, this tripod bag is particularly durable and resistant to wear and tear. Easily extend and fold your tripod in seconds, and keep it safely stored thanks to the bag's zippered closure, which can be fully opened. The padding will also act as a buffer between the tripod's exterior surface and hard edges, keeping the body and head resistant to damage. Plus, the inner pocket makes it easy for you to store and transport important accessories such as video head pan bars so you'll have everything you need for your shoot.



MB MBAG80N MB MBAG70N MB MBAG60N

## MB MBAG80N 80CM UNPADDED TRIPOD BAG

The MB MBAG80N is an unpadded tripod bag.

- Slightly tapered to provide a better fit for your tripod with attached head. The wider end of the bag accommodates the head without requiring all levers to be removed.
- Zipper extends down the length of the bag, but also fully opens the top end of the bag.
- Logo end cap is padded to offer protection to the tripod head, the rest of the bag is unpadded.
- Shoulder strap included (the MB MBAG80N doesn't have either end or side handle).
- Innovative design and style; ballistic nylon, zips and other materials used are of top quality. Diameter 13cm (5.1in).
- it can transport a tripod and attached head of up to 78cm long

## MB MBAG70N 70CM UNPADDED TRIPOD BAG

Same design of MB MBAG80N, it can transport a tripod and attached head of up to 68cm long.

## MB MBAG60N 70CM UNPADDED TRIPOD BAG

Same design of MB MBAG80N, it can transport a tripod and attached head of up to 58cm long.



## MB LBAG110 LIGHT STAND BAG 110CM FOR 3 LARGE LIGHT STANDS

This ergonomically designed light stand bag is the perfect heavy-duty choice for photographers on the go. This bag can carry a lot more than you might think. That's because its strong nylon design can withstand surprisingly heavy payloads, with capacity for up to 3 Quick Stack Light Stands of up to 109cm. And thanks to its water-repelling materials, you can keep your equipment protected whatever the weather. This light stand bag has a high-quality padded interior so you can easily store your gear.

## MB LBAG90 LIGHT STAND BAG 90CM FOR 4 COMPACT LIGHT STANDS

Same as MB LBAG110 but it can carry 4 quick-stack light stands measuring up to 90cm in length.



## MSTRAP-1 TRIPOD SHOULDER STRAP

The MSTRAP-1 allows you to carry the tripod when attached to the ring positioned right under the tripod collar.



For over fifty years, Lowepro's revolutionary camera bags, backpacks and cases have been on countless adventures and conquered a broad range of climates and conditions in the most remote parts of the world. The company has taken these experiences and grown with them to where they are today – a brand trusted the world over by passionate photographers, videographers, and content creators to protect and organise their gear on their creative journey. Since 1967, Lowepro have dedicated themselves to one single goal – to design camera bags that active creatives can truly rely on wherever their thirst for discovery takes them.

Developed by their committed design team in close collaboration with their customers and community of photographers, Lowepro bags are subjected to rigorous tests in both laboratory and field and crafted to meet the needs of any individual. Lowepro's studios in Italy are home to a dedicated team that gives almost obsessive attention to form factors, materials, and aesthetics. After harsh and relentless tests in the lab, their designers embark on extended backpacking trips, often right here in Italy, to assess all aspects of their new designs. They return full of ideas, stories to tell and photos to share.

Just like a good content creator relies on close relationships with their subjects, Lowepro relies on the integrity and strength of their friendships with like-minded partners who are as passionate about photography and the Great Outdoors as they are.

## Products:

- Pro Trekker series
- Hardside series
- GearUp series



# Pro Trekker series

Get big impact protection in a variety of sizes for point-and-shoots, CSC, action and 360 cameras, mirrorless, drones and large headphones.

## LP37272-PWW PRO TREKKER RLX 450 AW II

**Fits:** Up to 2 Pro DSLRs with attached lens (such Nikon D4S with up to 70-200mm f/2.8 or 300mm) 5-6 extra lenses (one up to 300mm) and speedlights Up to 15" laptop and 10" tablet Large smartphone, pro tripod and accessories

**Dimensions**

interior (WxDxH)

32 x 13 x 45 cm / 12.6 x 5.1 x 17.7 in

exterior (WxDxH)

36 x 25 x 52 cm / 14.1 x 10.2 x 20.5 in

**Weight**

4.06 kg / 8.95 lb



## LP37270-PWW PRO TREKKER BP 550 AW II

**Fits:** 4-6 extra lenses - Up to a 15-inch laptop, 10-inch tablet, plus Wacom type tablet - Compact digital gear like DJI Osmo or Mavic. Large smartphone, pro tripod and accessories 2-3 Pro DSLRs, one with up to 400mm lens attached

**Dimensions**

interior (WxDxH)

31 x 17 x 46 cm / 12.2 x 6.7 x 18.1 in

exterior (WxDxH)

35 x 24 x 62 cm / 13.8 x 9.5 x 24.4 in

**Weight**

3.65 kg / 13.1 lb



## LP37269-PWW PRO TREKKER BP 450 AW II

**Fits:** Up to 2 Pro DSLRs with attached lens (such Nikon D4S with up to 70-200mm f/2.8 or 300mm) 5-6 extra lenses (one up to 300mm) and speedlights Up to 15" laptop and 10" tablet Large smartphone, pro tripod and accessories

**Dimensions**

interior (WxDxH)

32 x 16 x 46 cm / 12.6 x 6.3 x 18.1 in

exterior (WxDxH)

35 x 25 x 49 cm / 13.7 x 9.8 x 19.3 in

**Weight**

2.7 kg / 5.95 lb





# Hardside series

Get big impact protection in a variety of sizes for point-and-shoots, CSC, action and 360 cameras, mirrorless, drones and large headphones.

## LP37165-PWW HARDSIDE CS 40

**Fits:** Point & shoot, pocket video, smartphone or other electronic device - Spare memory card, battery or other small accessories

**Dimensions**

interior (WxDxH)

8 x 4 x 13 cm / 3.1 x 1.6 x 5.2 in

exterior (WxDxH)

10.3 x 6.5 x 16.2 cm / 4 x 2.6 x 6.4 in

**Weight**

0.092 kg / 0.2 lb



## LP37164-PWW HARDSIDE CS 20

**Fits:** Compact point-and-shoot cameras - Spare memory card, battery or other small accessories

**Dimensions**

interior (WxDxH)

7 x 3 x 11.5 cm / 2.75 x 1.2 x 4.5 in

exterior (WxDxH)

9.3 x 6 x 14.5 cm / 3.7 x 2.4 x 5.7 in

**Weight**

0.09 kg / 0.19 lb



## LP37166-PWW HARDSIDE CS 60

**Fits:** 1-2 extra lenses - Spare memory card, battery or other small accessories - Small drone, 2 action cameras or compact mirrorless

**Dimensions**

interior (WxDxH)

11 x 6 x 19.5 cm / 4.3 x 2.4 x 7.7 in

exterior (WxDxH)

14 x 8.5 x 22.7 cm / 5.5 x 3.3 x 8.9 in

**Weight**

0.214 kg / 0.47 lb



## LP37167-PWW HARDSIDE CS 80

**Fits:** Small drone, compact cameras, small mirrorless cameras, large over-ear headphones and more!

**Dimensions**

interior (WxDxH)

17.5 x 8 x 20.5 cm / 6.9 x 3.1 x 8 in

exterior (WxDxH)

22 x 10.2 x 24.5 cm / 8.7 x 4 x 9.6 in

**Weight**

0.294 kg / 0.64 lb



# GearUp series

Get your kit together with these lightweight, protective cases designed with flexibility and customization in mind. Carry cords, cables, chargers and more in the configuration that works best for you!

## LP37347-PWW GEARUP CREATOR BOX M II

**Fits:** Mirrorless cameras like Sony a6500 or Olympus Pen-F plus additional lens Spare batteries and charger Memory cards, lens caps and personal items DJI Mavic Air with controller

**Dimensions**

interior (WxDxH)

13.5 x 8 x 18 cm / 5.3 x 3.1 x 7 in

exterior (WxDxH)

18 x 11 x 20 cm / 7 x 4.3 x 7.9 in

**Weight**

0.2 kg / 0.44 lb



## LP37348-PWW GEARUP CREATOR BOX L II

**Fits:** DJI Mavic Pro Mirrorless cameras like Sony a7, Olympus OM-D E-M10 or Canon EOS M5 Memory cards and accessories Spare batteries and charger

**Dimensions**

interior (WxDxH)

16.5 x 9.5 x 24 cm / 6.5 x 3.7 x 9.4 in

exterior (WxDxH)

20 x 12.5 x 26 cm / 7.8 x 4.9 x 10.2 in

**Weight**

0.25 kg / 0.55 lb



## LP37349-PWW GEARUP CREATOR BOX XL II

**Fits:** Mirrorless, compact drone or DSLR with up to 70-200mm attached lens Memory cards and accessories Spare batteries and charger

**Dimensions**

interior (WxDxH)

21 x 12.5 x 28 cm / 8.2 x 4.9 x 11 in

exterior (WxDxH)

24 x 15 x 30 cm / 9.4 x 6.3 x 11.8 in

**Weight**

0.4 kg / 0.88 lb







# GearUp series



## LP37138 GEARUP POUCH MINI

**Fits:** All the cords and accessories needed to keep your smartphone going.

**Dimensions**

*interior (WxDxH)*

19 x 4 x 11.5 cm / 7.5 x 1.6 x 4.5 in

*exterior (WxDxH)*

22 x 4.5 x 14 cm / 8.7 x 1.8 x 5.5 in

**Weight**

90 g / 3.2 oz



## LP37139 GEARUP POUCH MEDIUM

**Fits:** Laptop essentials. Small power supply, cords, mouse and small accessories.

**Dimensions**

*interior (WxDxH)*

26 x 4 x 11.5 cm / 10.2 x 1.6 x 4.5 in

*exterior (WxDxH)*

28 x 4.5 x 14 cm / 11.0 x 1.8 x 5.5 in

**Weight**

112 g / 4.0 oz



## LP37141 GEARUP CASE LARGE

**Fits:** All of your device accessories for travel and commute. Higher level of protection for headphones and cameras.

**Dimensions**

*interior (WxDxH)*

25 x 6 x 16 cm / 9.8 x 2.4 x 6.3 in

*exterior (WxDxH)*

29 x 8 x 17 cm / 11.4 x 3.1 x 6.7 in

**Weight**

198 g / 7.0 oz



## LP37185 GEARUP FILTER POUCH 100

**Fits:** Holds a variety of round and sheet filters and filter mount (such as 10 sheet filters up to 100mm x 150mm and 2 circular filters up to 72mm and 1 filter holder).

**Dimensions**

*interior (WxDxH)*

13 x 6 x 18 cm / 5.1 x 2.4 x 7.1 in

*exterior (WxDxH)*

15 x 8 x 20 cm / 5.9 x 3.2 x 7.9 in

**Weight**

0.35 kg / 12.3 oz



## LP37186 GEARUP MEMORY WALLET 20

**Fits:** Holds a wide variety of portable flash media cards (such as 12 CF or XQD cards and 8 SD cards)

**Dimensions**

*interior (WxDxH)*

15 x 4 x 6 cm / 5.9 x 1.6 x 2.4 in

*exterior (WxDxH)*

16 x 5.5 x 7 cm / 6.3 x 2.2 x 2.8 in

**Weight**

40 g / 1.41 oz



## LP37140 GEARUP WRAP

**Fits:** Streamlined organizer for your minimal smartphone travel kit. Ideal spot for your short cord collection and flat USB charger or battery.

**Dimensions**

*interior (WxDxH)*

19 x 0 x 10.5 cm / 7.5 x 0.0 x 4.1 in

*exterior (WxDxH)*

19 x 0 x 10.5 cm / 7.5 x 0.0 x 4.1 in

**Weight**

60 g / 2.1 oz





Syrp was born in New Zealand from a passion for creative filmmaking and a need for portable, user-friendly smart motion control technology. Syrp designs and manufactures solutions for the enabling and controlling of camera movement for motion video, time-lapse, product photography, panorama and many more applications besides. Syrp products are packed with the most innovative technology, controlled wirelessly via a beautifully simple and intuitive app, and compatible with an ever-expanding product line. Syrp's intuitive solutions are easy to setup and operate.

They are ideally suited to every user – from entry-level content creators to the most experienced professionals, allowing them to concentrate purely on their creativity – leading to their products having won numerous prestigious awards. Portability is of course another key feature, giving filmmakers the option of using motion control regardless of location.

Syrp's products are uniquely modular and can be used with other third-party equipment as well as Syrp's own accessories – including camera sliders and cable cam systems. With the flexibility to combine multiple motion controllers together, content creators can start small and expand their kit as they develop their skills – achieving a wider range of motion possibilities and an expanded feature list. Syrp's human-centred design and relentless focus on innovation make them a clear leader in the market for motion control technology.

## Products:

Motion Controllers  
Magic Carpet Sliders  
Genie Kits



# The Genie Family of Motion Controllers - Overview

Designed to be part of your regular camera kit, with a focus on simplifying setup and portability there's no need to ever go without Motion Control again. Create spectacular motion time-lapse, video and panorama in any location.

|                       | Axis of Movement    | iOS & Android App Control | On Board Display | Quick Release | Removable Batteries | Intergrated Joystick |
|-----------------------|---------------------|---------------------------|------------------|---------------|---------------------|----------------------|
| <br>Genie Mini II     | Panning             | ●                         |                  |               |                     |                      |
| <br>Genie II Pan Tilt | Panning & Tilting   | ●                         | ●                | ●             | ●                   | ●                    |
| <br>Genie II Linear   | Tracking            | ●                         |                  | ●             | ●                   | ●                    |
| <br>Genie One         | Panning or Tracking | ●                         |                  |               |                     |                      |

## Features



### Multi-Axis Ready

Combine any number of Genie devices together to create up to 3-axis motion, all controlled from the Syrp App.

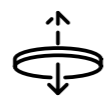

### Syrp Quick Release

Innovative new quick release system makes setup of tripods, sliders and cameras easier than ever.



### iOS & Android Control

Control the Genie with a beautifully simple App that accommodates both beginners through to the experienced.



### Removable Batteries

Take extra batteries for shooting in remote locations, and swap batteries between Genie II Linear and Pan Tilt.



### On Board LCD Display

Setup and shoot time-lapse and video recording directly via the on board display.



### Integrated Joystick

Control the Genie via the joystick for instant repositioning and quick 'run and gun' camera movements. Set up basic recordings with Genie II Pan Tilt LCD.

# Genie mini II

Create spectacular motion time-lapse, video and panorama with our simple-to-use smart motion control device.



The perfect entry-level time-lapse tool as well as a professional add-on to our current Genie range for multi-axis control. Operated by a beautifully simple app with factory presets, you will never need to go without motion control again.

- Panning motion control with Keyframing for video and time-lapse
- Panorama and \*multi-row panorama recording
- Product Turntable mode
- Battery included
- Compatible with 1000's of camera's\*\*
- Full iOS and Android App control via Bluetooth

\*Requires a 2nd Genie Mini II and the Pan Tilt Bracket accessory  
\*\*Select a Shutter link cable for your camera at [www.syrp.co](http://www.syrp.co)  
(Not required for video recording)



SY0033-0001  
**Genie Mini II**



**Charge Time**  
3hrs

**Battery Life**  
15hrs Time-lapse  
6hrs Video

**Weight**  
0.245kg / 0.54lbs

**Max Payload**  
4kg / 8.8lbs

## Genie Mini II Accessories

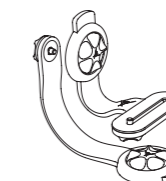

SY0003-0001  
**Pan Tilt Bracket**

Combined with two Genie Mini II's, the Pan Tilt Bracket allows you to create pan tilt time-lapse, video and multi-row panorama.

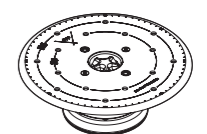

SY0025-0001  
**Product Turntable**

Automate your product photography workflow with precision and repeatability for creating interactive 360° images of objects and record smooth rotating video with ease.



## Genie II Pan Tilt

A powerful 2-Axis motion controller giving you the creative freedom of 180° Tilt and 360° Panning movement.



Portable camera motion control in your backpack. Genie II Pan Tilt offers the filmmaker a world of options when out filming. Use it with a tripod for precise pan and tilt motion control or combine it with Genie II Linear for 3-Axis motion control.

- Full keyframe setup for Time-lapse and Video
- On-board physical joystick for quick repositioning
- Setup and record directly via the on board display.
- Removable li-ion battery (included)
- Syrp Quick Release system
- Multi-row Panorama - Gigapixel and 360 ° images
- Ultra-compact and portable
- Compatible with 1000's of camera's\*
- Full iOS and Android App control via Bluetooth

\*Select a Shutter link cable for your camera at [www.syrp.co](http://www.syrp.co) (Not required for video recording)



SY0031-0001  
**Genie II Pan Tilt**



**Charge Time**  
3hrs

**Battery Life**  
12hrs Time-lapse  
8hrs Video

**Weight**  
1.93kg / 4.25lbs

### Genie II Pan Tilt Accessory



SY0005-0002  
**Battery BP02**

Take extra batteries for shooting in remote locations. Both Genie II Linear and Genie II Pan Tilt conveniently use the same battery.

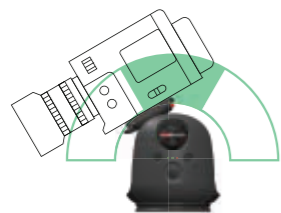

**Max Payload Tilting 60°**  
6kg / 13.23lbs

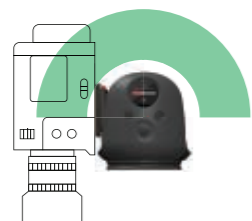

**Max Payload Tilting 180°**  
3kg / 6.61lbs



## Genie II Linear

Record silky smooth tracking motion for time-lapse or video with any slider on the market.



Genie II Linear is a highly portable and versatile solution for motion control. Our unique Genie rope system can attach to any slider on the market, giving you precise linear motion control up to 100m.

- Full keyframe setup for Time-lapse and Video
- On-board physical joystick for quick repositioning
- Removable li-ion battery (included)
- Syrp Quick Release system
- Multi-axis ready, combine with the Genie II Pan Tilt or Mini II
- Universal slider, dolly and cable cam compatibility
- Compatible with 1000's of camera's\*
- Full iOS and Android App control via Bluetooth

\*Select a Shutter link cable for your camera at [www.syrp.co](http://www.syrp.co) (Not required for video recording)



SY0038-0003  
**Genie II Linear**



**Charge Time**  
3hrs

**Battery Life**  
14hrs Time-lapse  
8hrs Video

**Weight**  
1.42kg / 3.13lbs

### Genie II Pan Tilt Accessory

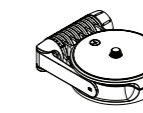

SY0054-0001  
**Tilt Platform**

Create unique shots by keeping your camera level while tracking vertically. Compatible with both manually operated or motion-controlled sliders.



SY0005-0002  
**Battery BP02**

Take extra batteries for shooting in remote locations. Both Genie II Linear and Genie II Pan Tilt conveniently use the same battery.

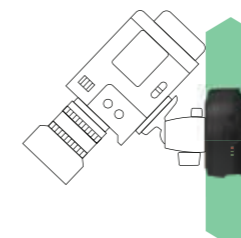

**Max Payload Vertical**  
2.5kg / 5.51lbs

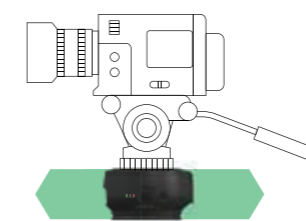

**Max Payload Horizontal**  
7.5kg / 16.53lbs



# Genie One

A versatile motion controller that offers the option of tracking or panning motion for time-lapse or video recording.

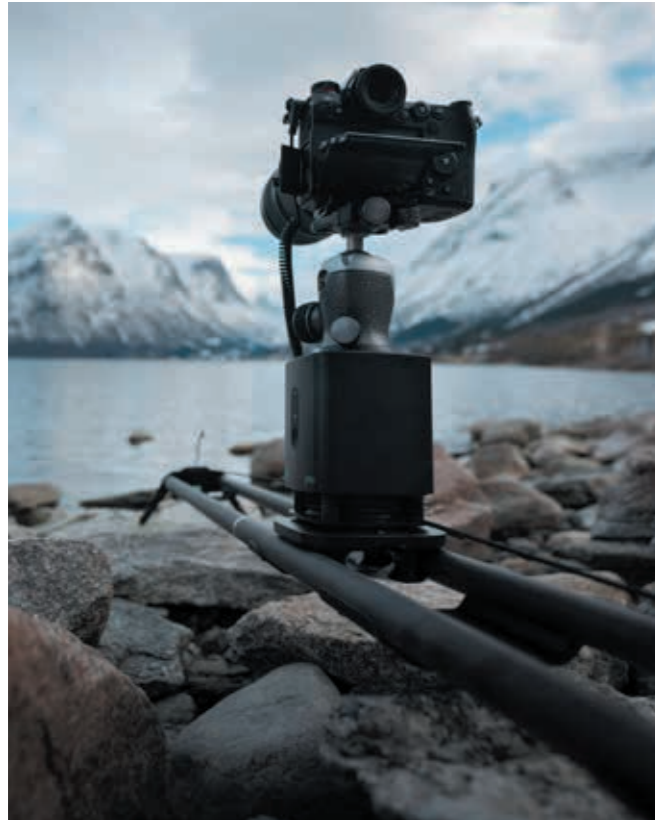

Mount the Genie One to a tripod to record smooth panning shots or connect it to any slider on the market to shoot silky smooth tracking shots. The key to the Genie lies in its ability to go from panning to tracking with a simple click into either the Panning Accessory or Linear Accessory. The original Genie set the benchmark in portable motion control and the Genie One is that much-loved product re-imagined with all our latest technology. Now with wireless control using the Syrp app combined with long battery life and a rugged body the Genie One is a motion control powerhouse.

- Panning or Linear motion control for video and time-lapse
- Panorama, Live Drive and Turntable modes
- iOS and Android App control via Bluetooth
- Battery life: 5hrs Video and 48hrs Time-lapse
- Set Keyframes for more advanced movement control



SY0060-0001  
**Genie One**



**Charge Time**  
3hrs

**Battery Life**  
148hrs Time-lapse  
5hrs Video

**Weight**  
2kg / 4.4lbs

### Genie One Accessory

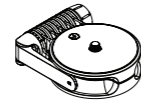

SY0054-0001  
**Tilt Platform**

# Genie Micro

Genie Micro is an all-in-one smart remote allowing you to control your camera from our intuitive smart phone app.



- Use the Syrp App to remotely control camera settings like aperture, shutter speed and ISO
- Easily setup time-lapses from the app specifying record time, interval and playback time
- HDR mode for time-lapse and photography
- Live Control mode for adjusting exposure settings and trigger a photo or start a video
- Use Live Control Mode for Stop Motion without having to touch your camera

The Genie Micro is an all-in-one smart remote for mirrorless and DSLR cameras, allowing you to control your camera from our intuitive smart-phone app. Simply slide into the hot shoe, connect your camera and pair with the app.

Please note: An additional Shutter Link Cable is required for standard triggering. Camera control requires the USB cable that comes with your camera.



SY0036-0001  
**Genie Micro**



# The Magic Carpet Family of Sliders - Overview

Shoot supremely smooth manual tracking shots and add amazing production value to your films. Our camera sliders are beautifully designed and engineered with the filmmaker in mind.

|                      | Vertical Shooting | Toolless Operation | Extendable | Ultralight Weight | Quick Release | Pro Payloads | Flywheel |
|----------------------|-------------------|--------------------|------------|-------------------|---------------|--------------|----------|
| <br>Magic Carpet     | •                 | •                  |            |                   |               |              |          |
| <br>Magic Carpet CF  | •                 | •                  | •          | •                 |               |              |          |
| <br>Magic Carpet PRO | •                 | •                  | •          |                   | •             | •            | •        |

### Features

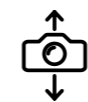

**Vertical shooting with counter weight**  
Record unique vertical shots with inbuilt counter weight wheels.

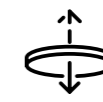

**Syrp Quick Release System**  
Simply attach the QR Plate to your camera or Tripod head and click it straight in to Magic Carpet PRO to shoot.



**Tool-less Operation**  
Connect, adjust, release and fine tune all features of the slider with no tools required.



**PRO Payloads**  
Built to withstand the demands of pro filmmaking and produce smooth movement with heavier camera loads.



**Endlessly Extendable**  
Connect multiple tracks together for longer tracking movements.



**Flywheel**  
Integrated Flywheel ensures that your hand-operated tracking shots are silky smooth every time.



**Ultralight Weight**  
Portable and lightweight for the intrepid time-lapse photographer and filmmaker.





# Magic Carpet

A simple and durable slider for silky smooth professional tracking movements that's motion control ready.



The Magic Carpet slider has been designed and engineered with the filmmaker in mind. With quick release adjustable legs, a counter weight roller for vertical shots, and high precision ball bearing rollers. The Magic Carpet is ready for quick set up and silky-smooth tracking.

- Portable and lightweight
- Adjustable legs with fine adjustment feet
- Vertical shooting with counterweight wheels
- Made from durable aluminum
- Silky smooth ball bearing roller carriage

|  |   |   |
|--|---|---|
| <br><b>Material</b> | <br><b>Weight</b> | <br><b>Max Payload</b> |
| Aluminium T6   | 1.7kg / 3.75lbs<br>(60cm / 1.97ft)  | 5kg / 11lbs   |

## Magic Carpet Slider Range

## Components

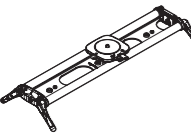
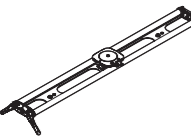
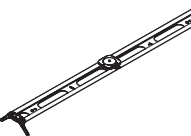
|   | Weight          | Max Payload | True Sliding Length | End Caps & Carriage | Short Track 60cm   | Medium Track 100cm | Long Track 160cm   | Carry Bag      |
|---|-----------------|-------------|---------------------|---------------------|--------------------|--------------------|--------------------|----------------|
| <br>SYKIT-0018H<br><b>Short Slider (60cm / 1.97ft)</b>   | 1.7kg / 3.75lbs | 5kg / 11lbs | 48cm / 1.5ft        | ●<br>SY0013-0001    | ●<br>SY0013-4001-5 |                    |                    | ○<br>Not Incl. |
| <br>SYKIT-0017H<br><b>Medium Slider (100cm / 3.28ft)</b> | 2.2kg / 4.85lbs | 5kg / 11lbs | 88cm / 2.9ft        | ●<br>SY0013-0001    |                    | ●<br>SY0013-4001-6 |                    | ○<br>Not Incl. |
| <br>SYKIT-0016H<br><b>Long Slider (160cm / 5.25ft)</b>   | 2.6kg / 5.73lbs | 5kg / 11lbs | 148cm / 4.86ft      | ●<br>SY0013-0001    |                    |                    | ●<br>SY0013-4001-4 | ○<br>Not Incl. |



## Magic Carpet Accessories

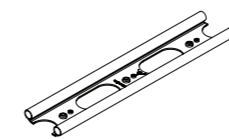

### Magic Carpet Tracks

Add additional track lengths to your kit and swap them between your existing Magic Carpet End Caps & Carriage effortlessly without tools.

|                             |               |
|-----------------------------|---------------|
| <b>Short Track (60cm)</b>   | SY0013-4001-5 |
| <b>Medium Track (100cm)</b> | SY0013-4001-6 |
| <b>Long Track (160cm)</b>   | SY0013-4001-4 |

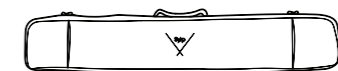

### Carry Bag

Transport your slider with ease and protect your track while traveling with our padded carry bag.

|                             |             |
|-----------------------------|-------------|
| <b>Short Track (60cm)</b>   | SY0044-0005 |
| <b>Medium Track (100cm)</b> | SY0044-0006 |
| <b>Long Track (180cm)</b>   | SY0044-0002 |

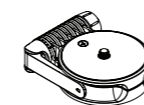

### SY0054-0001 Tilt Platform

Create unique shots by keeping your camera level while tracking vertically. Compatible with both manually operated or motion-controlled sliders.







# Magic Carpet CF

Versatile and feather-light slider option for the intrepid time-lapse photographer and filmmaker.



The Magic Carpet Carbon Fibre slider is endlessly extendable, and packed away to 60cm/2' sections, the Magic Carpet Carbon Fibre means never having to sacrifice camera gear for suitcase space again.

- Infinitely extendable for longer tracking moves
- Ultra portable and lightweight design
- Seamless joining for smooth and stable shooting
- Vertical shooting with counterweight wheels
- Interchangeable end caps & carriage with Aluminum Magic Carpet.

|  |  |  |  |
|--|--|--|--|
| <br><b>Material</b><br>Carbon Fibre | <br><b>Weight</b><br>1.5kg / 3.3lbs<br>(60cm / 1.97ft) | <br><b>Max Payload</b><br>5kg / 11lbs | <br><b>Extendable</b> |
|--|--|--|--|

## Magic Carpet Carbon Slider Range

## Components

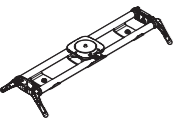
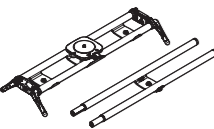
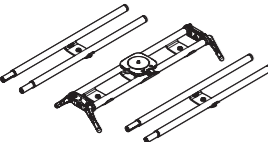
|  | Weight         | Max Payload | True Sliding Length | End Caps & Carriage | Carbon Track 60cm | Carbon Extension 60cm  | Carry Bag      |
|--|----------------|-------------|---------------------|---------------------|-------------------|------------------------|----------------|
| <br>SYKIT-0034H<br><b>Carbon Slider 60cm / 1.97ft</b>   | 1.5kg / 3.3lbs | 5kg / 11lbs | 48cm / 1.5ft        | ●<br>SY0013-0001    | ●<br>SY0013-0011  |                        | ○<br>Not Incl. |
| <br>SYKIT-0015H<br><b>Carbon Slider 120cm / 3.94ft</b> Includes 60cm Track and 60cm Extension | 1.88kg / 3.97  | 5kg / 11lbs | 108cm / 3.54ft      | ●<br>SY0013-0001    | ●<br>SY0013-0011  | ●<br>SY0013-0012       | ○<br>Not Incl. |
| <br>SYKIT-0014H<br><b>Carbon Slider 180cm / 5.9ft</b> Includes 60cm Track and 2x 60cm         | 2.26kg / 4.98  | 5kg / 11lbs | 168cm / 5.51ft      | ●<br>SY0013-0001    | ●<br>SY0013-0011  | ●●<br>(2x) SY0013-0012 | ○<br>Not Incl. |



## Magic Carpet CF Accessories

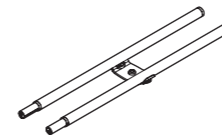

SY0013-0012  
**Carbon Fibre Extensions**  
Produce extra-long tracking shots by extending your Carbon Slider with seamless extensions.

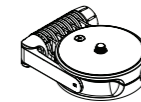

SY0054-0001  
**Tilt Platform**  
Create unique shots by keeping your camera level while tracking vertically. Compatible with both manually operated or motion-controlled sliders.



SY0044-0001  
**Carbon Carry Bag**  
Transport your slider with ease and protect your track and extensions while traveling with our padded carry bag.







# Magic Carpet PRO

Built to withstand the demands of pro filmmaking. The Magic Carpet Pro has been designed to produce supremely smooth tracking moves with heavier camera loads.



Magic Carpet Pro offers a tool-less set up, integrated flywheel, a patent-pending quick release system and the ability to connect multiple tracks together for longer tracking movements. Packed with innovative features the Magic Carpet Pro is the perfect slider system for any serious filmmaker.

- Press button engagement in-built motion smoothing flywheel
- Quick release plate for rapid setup and slider maneuverability
- Infinitely extendable with additional 2ft or 3ft tracks
- Syrp motion control ready for adding up to 3-axis
- Support for professional cameras up to 70lbs/32kgs

|  |  |  |  |
|--|--|--|--|
| <br><b>Material</b><br>Aluminium T6 | <br><b>Weight</b><br>4.9kg / 10.8lbs<br>(61cm / 2ft) | <br><b>Max Payload</b><br>32kg / 70.5lbs<br>23kg / 50.7lbs<br>(with extensions) | <br><b>Extendable</b> |
|--|--|--|--|



## Magic Carpet PRO Accessories

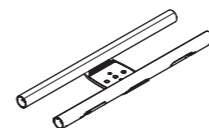

### Magic Carpet PRO Tracks

Produce extra-long tracking shots by extending your slider with seamless extensions.

**Short Track (61cm)** SY0018-0009

**Medium Track (91cm)** SY0018-0010



### SY0016-0003 Quick Release Plate 90mm

Quickly attach or remove your tripod head directly from the carriage with ease using our patent pending quick release system.

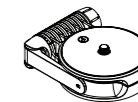

### SY0054-0001 Tilt Platform

Create unique shots by keeping your camera level while tracking vertically. Compatible with both manually operated or motion-controlled sliders.

## Magic Carpet PRO Slider Range

### Components

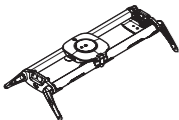
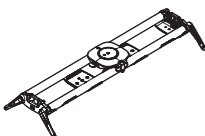
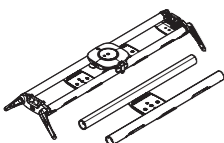
|  | Weight           | Max Payload    | True Sliding Length | Pro End Caps & Carriage | Pro Short Track 61cm | Pro Medium Track 91cm | Carry Bag  |
|--|------------------|----------------|---------------------|-------------------------|----------------------|-----------------------|------------|
| <br>SYKIT-0022H<br><b>PRO Short Slider 61cm / 2ft</b>   | 4.9kg / 10.8     | 32kg / 70.5lbs | 43cm / 1.4ft        | ●<br>SY0018-0019        | ●<br>SY0018-0009     |                       | ●<br>Incl. |
| <br>SYKIT-0020H<br><b>PRO Medium Slider 91cm / 3ft</b>  | 5.7kg / 12.6lbs  | 32kg / 70.5lbs | 86cm / 2.82ft       | ●<br>SY0018-0019        |                      | ●<br>SY0018-0010      | ●<br>Incl. |
| <br>SYKIT-0021H<br><b>PRO Slider + Extension 152cm / 5ft</b> Includes 61cm Track and 91cm Track | 7.4kg / 16.31lbs | 23kg / 50.7lbs | 134cm / 4.4ft       | ●<br>SY0018-0019        | ●<br>SY0018-0009     | ●<br>SY0018-0010      | ●<br>Incl. |

## Magic Carpet PRO's Innovative Features

Magic Carpet PRO is meticulously designed for the requirements of professional filmmakers with a focus on reduced setup time and ensuring supremely smooth tracking shots every time.

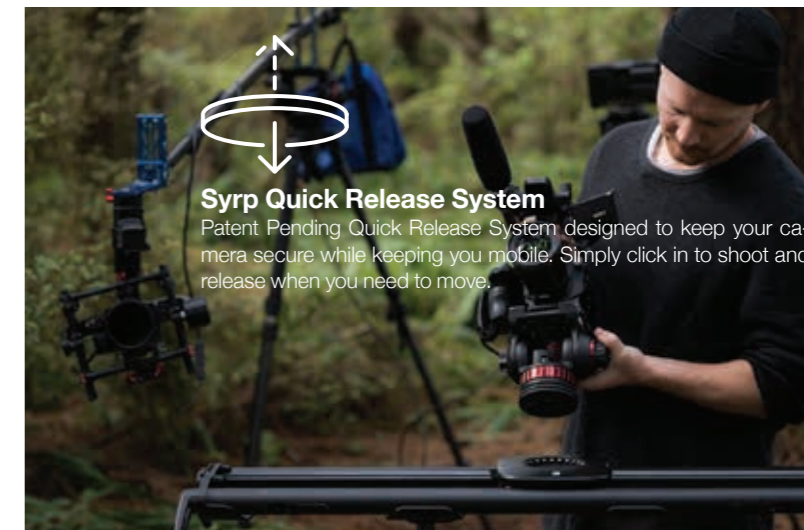

### Syrp Quick Release System

Patent Pending Quick Release System designed to keep your camera secure while keeping you mobile. Simply click in to shoot and release when you need to move.

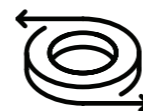

### Motion Smoothing Flywheel

Even with the most demanding payloads, the Carriage-integrated Flywheel ensures your hand-pushed tracking shots are silky smooth every time.



### Endlessly Extendable

Our zero-join technology allows you to extend your track length as long as you need to without compromising on the quality of your shot.







# The Genie Modular System

Our modular motion control system allows you to build up multiple axis of movement by simply connecting different Syrp motion control products together. Sync them wirelessly using the Syrp App and shoot precise motion control. Portable, expandable, simple.

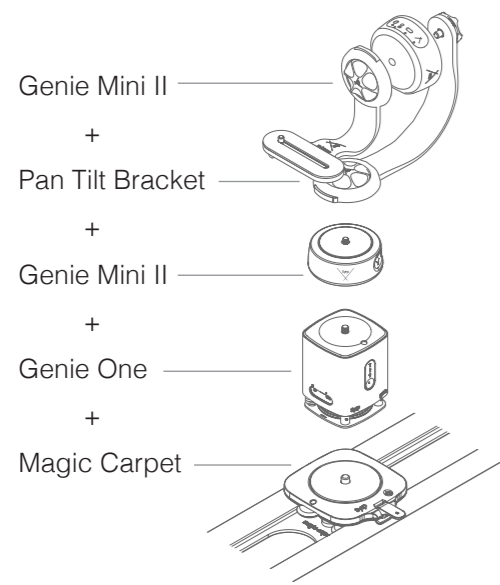

**Genie One 3-Axis - Custom Build**

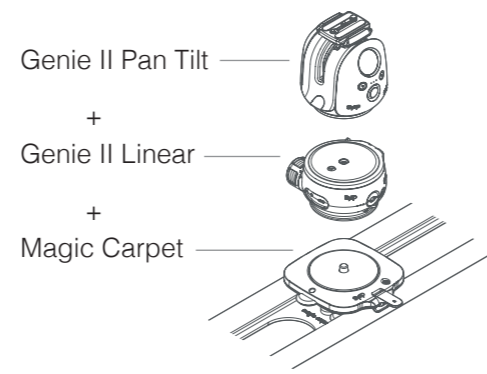

**Genie II 3-Axis - Epic Kit Build**

# The Genie Kits Range

|  | Axis of Movement | Magic Carpet Medium | Genie | Genie Mini II | Genie II Linear | Genie II Pan Tilt | Accessory         |
|--|------------------|---------------------|-------|---------------|-----------------|-------------------|-------------------|
|  | Pan & Tilt       |                     |       | ●●<br>(2x)    |                 |                   | Pan Tilt Bracket  |
| <b>Genie Mini II - Pan Tilt Kit</b>          |                  |                     |       |               |                 |                   |                   |
|  | Panning          |                     |       | ●             |                 |                   | Product Turntable |
| <b>Genie Mini II - Product Turntable Kit</b> |                  |                     |       |               |                 |                   |                   |
|  | 3-Axis           | ●                   |       | ●●<br>(2x)    | ●               |                   | Pan Tilt Bracket  |
| <b>Genie II 3-Axis - Indie Kit</b>           |                  |                     |       |               |                 |                   |                   |
|  | 3-Axis           | ●                   |       |               | ●               | ●                 |                   |
| <b>Genie II 3-Axis - Epic Kit</b>            |                  |                     |       |               |                 |                   |                   |



Product Turntable

Pan & Tilt

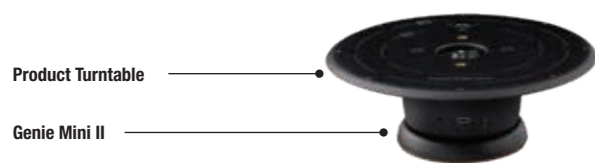

SYKIT-0043  
**Genie Mini II - Product Turntable Kit**  
Automate your product photography workflow with precision and repeatable controlled moves.

- 1x Product Turntable SY0025-0001
- 1x Genie Mini II SY0033-0001

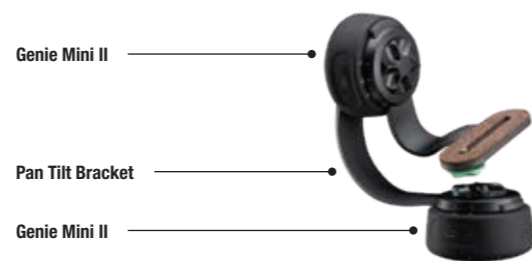

SYKIT-0040H  
**Genie Mini II - Pan Tilt Kit**  
Recording smooth 2-axis Pan and Tilt motion for time-lapse and video with this simple-to-use smart motion device.

- 2x Genie Mini II SY0033-0001
- 1x Pan Tilt Bracket SY0003-0001



Genie 3-Axis Kits



SYKIT-0042  
**Genie II 3-Axis - Indie Kit**  
Create epic time-lapse and video shots with 3-axis motion control on an indie budget.

- 2x Genie Mini II SY0033-0001
- 1x Pan Tilt Bracket SY0003-0001
- 1x Genie II Linear SY0038-0003
- 1x Magic Carpet Medium Track 100cm SY0013-4001-6
- 1x Magic Carpet End Caps & Carriage SY0013-0001



SYKIT-0002  
**Genie II 3-Axis - Epic Kit**  
Ultimate Genie II 3-Axis motion control utilising Syrrp's latest technology.

- 1x Genie II Pan Tilt SY0031-0001
- 1x Genie II Linear SY0038-0003
- 1x Magic Carpet Medium Track 100cm SY0013-4001-6
- 1x Magic Carpet End Caps & Carriage SY0013-0001



Gitzo is recognised worldwide as the premium brand for outstanding tripods, monopods, heads, and a comprehensive range of photographic accessories – and it's easy to see why. Every element of the Gitzo manufacturing process revolves around lightweight and high-quality materials, employing precision assembly and strict quality control. The uncompromising craftsmanship of Gitzo products has at its core the equally demanding expectations of the professional photographer.

Gitzo products are designed to shine, withstand, and last. Mechanical ingenuity and ergonomics present the embodiment of timeless, purpose-led elegance.

Superior form and function are present in equal measure – an effortless balance of aesthetics and unrivalled usability that has won numerous awards throughout the years.

A love of design and innovation is at the heart of Gitzo's commitment. They strive to produce the best possible camera accessories and supports using the most effective and straightforward solutions – however long and complex the path to get there. Every individual product is assembled, checked, and packaged – by hand and by craftspeople devoted to the highest precision and quality.

Gitzo has remained at the industry's cutting edge by using space-age materials such as high-strength, lightweight aluminium alloys and carbon fibre tubing. This spirit has helped Gitzo pioneer the most advanced and revolutionary technologies, while maintaining its enthusiasm, philosophy, and traditions. Gitzo photographers continue to enjoy the constantly evolving industry standards that they have come to expect from us. Gitzo products are proudly made in ITALY and conform to Vitec Imaging Solutions' ISO 14001 Environmental Management Certification System.

## Products:

Tripods  
Tripods accessories  
Heads



# Systematic tripods

The Systematic Tripod family opens the door to a new dimension for devoted videographers. For those who use long lenses and a heavy camera, the Systematic, the most stable and versatile of all tripods, will become a life-long partner at the first use.



series

## 3.

top leg ø: 32.0mm

Series 3 is the perfect choice for those who want to travel light but need enough stability for professional equipment.

series

## 4.

top leg ø: 37.0mm

The Series 4 Systematics are becoming popular thanks to the rigidity from large leg diameters, while the top casting (shared with Series 3 models) is less bulky compared to Series 5 models and therefore easier to store and carry. The GT4553S has a short folded length with its 5-section construction.

series

## 5.

top leg ø: 41.3mm

The choice of the most demanding professionals, Series 5 Systematic tripods are the most rigid tripods in the whole Gitzo range. Compatible with Series 5 Systematic accessories, the top casting is larger than that of Series 3 and 4 Systematics in order to provide maximum stability. The GT5563GS is the iconic 6-section Giant tripod, towering at an extended height of 278cm.

| series | ref.      | legs tube Ø                          | interchangeable feet | ⋮ | ⌵            | ⌶         | ⌷          | ⌸             | ⌹           |
|--------|-----------|--------------------------------------|----------------------|---|--------------|-----------|------------|---------------|-------------|
| 3.     | GT3533S   | 32.9, 29.0, 25.3mm                   | •                    | 3 | 130cm/51.2"  | 9cm/3.5"  | 61cm/24.0" | 1.93kg/4.3lbs | 25kg/55lbs* |
| 3.     | GT3533LS  | 32.9, 29.0, 25.3mm                   | •                    | 3 | 152cm/59.8"  | 11cm/4.3" | 67cm/26.4" | 2.04kg/4.5lbs | 25kg/55lbs* |
| 3.     | GT3543LS  | 32.9, 29.0, 25.3, 21.7mm             | •                    | 4 | 146cm/57.5"  | 9cm/3.5"  | 67cm/22.4" | 2.03kg/4.5lbs | 25kg/55lbs* |
| 3.     | GT3543XLS | 32.9, 29.0, 25.3, 21.7mm             | •                    | 4 | 202cm/79.5"  | 10cm/3.9" | 71cm/28.0" | 2.29kg/5.0lbs | 25kg/55lbs* |
| 4.     | GT4553S   | 37.0, 32.9, 29.0, 25.3, 21.7mm       | •                    | 5 | 136cm/53.5"  | 9cm/3.5"  | 48cm/19.9" | 2.23kg/4.9lbs | 25kg/55lbs* |
| 4.     | GT4533LS  | 37.0, 32.9, 29.0mm                   | •                    | 3 | 156cm/61.4"  | 11cm/4.3" | 69cm/27.2" | 2.31kg/5.1lbs | 25kg/55lbs* |
| 4.     | GT4543LS  | 37.0, 32.9, 29.0, 25.3mm             | •                    | 4 | 158cm/62.2"  | 10cm/3.9" | 61cm/24.0" | 2.38kg/5.2lbs | 25kg/55lbs* |
| 5.     | GT5533S   | 41.3, 37.0, 32.9mm                   | •                    | 3 | 134cm/52.8"  | 10cm/3.9" | 62cm/24.4" | 2.63kg/5.8lbs | 40kg/88lbs* |
| 5.     | GT5533LS  | 41.3, 37.0, 32.9mm                   | •                    | 3 | 145cm/57.1"  | 10cm/3.9" | 68cm/26.8" | 2.72kg/6.0lbs | 40kg/88lbs* |
| 5.     | GT5543LS  | 41.3, 37.0, 32.9, 29.0mm             | •                    | 4 | 156cm/61.4"  | 10cm/3.9" | 60cm/23.6" | 2.82kg/6.2lbs | 40kg/88lbs* |
| 5.     | GT5543XLS | 41.3, 37.0, 32.9, 29.0mm             | •                    | 4 | 198cm/78.0"  | 10cm/3.9" | 72cm/28.3" | 3.12kg/6.9lbs | 40kg/88lbs* |
| 5.     | GT5563GS  | 41.3, 37.0, 32.9, 29.0, 25.3, 21.7mm | •                    | 6 | 278cm/109.4" | 10cm/3.9" | 73cm/28.7" | 3.56kg/7.8lbs | 40kg/88lbs* |



# Systematic tripods accessories

All the latest Systematic accessories feature a safety catch that prevents the center accessory dropping out of the tripod, even if the top casting is inadvertently left unlocked. When used together with the latest Systematic tripods equipped with the corresponding safety button, the accessory is always held safely in place until the release button is pushed. Newer Systematic accessories can also be used with older Systematic tripods (and vice versa), but without this extra safety feature.

Systematic accessories are available in 2 sizes that match the top castings of Systematic tripods: Series 3 accessories have 7cm diameter attachments to fit all Series 3 and 4 Systematic tripods except for older Series 4 aluminum Systematic tripods; Series 5 accessories have 8.5cm diameter attachments and fit Series 5 Systematic tripods and the older Series 4 aluminum models.

## video adapters

75mm and 100mm half ball adaptors quickly transform any Systematic tripod into a professional video support.

series 3.4.   serie 5.

GS3321V75 (Ø 75mm)      GS3322V100 (Ø 100mm)      GS5321V75 (Ø 75mm)      GS5321V100 (Ø 100mm)



## leveling base

GSLVLS

Fits into Systematic tripods via the optional 75mm video adapter GS3321V75 or GS5321V75, and provides tilt in all directions for levelling the panning axis of flat base video heads and photographic heads. Leveling base GSLVLS has become lighter and more ergonomic with the new grip.

## top flat plates

GS3321SP (series 3.4.)  
GS5321SP (serie 5.)

The top flat plate supplied with the latest Systematic tripods offers a convenient way to upgrade previous Systematic tripods. Features a sand bag hook and a special grub screw to securely lock a head in place on the plate. On model GS5321SP, the position of this screw is adjustable for compatibility with a wider range of heads.

## systematic head

GH5381SQD

This head is designed to fit the upper casting of Systematic tripods, guaranteeing an ultra-stable platform for high precision equipment. Reduced weight, smoothness, ease of use and strong locking make it ideal for long lens applications. Includes the D-profile (Arca-Swiss compatible) quick release plate GS5370D. Fits all Systematic tripods.



## columns

series 3.4.\*

GS3313GS  
**Aluminum**  
geared column

GS3513S  
**Carbon**  
rapid column

series 5.

GS5313GS  
**Aluminum**  
geared column

GS5313LGS  
**Aluminum**  
geared column long

GS5513S  
**Carbon**  
rapid column

GS5513XLS  
**Carbon**  
rapid column xl



\*For compatibility with Series 4 Systematic aluminum tripods, choose Series 5 accessories.

| series | ref.      | material | type                      | travel     | h                                | weight        |
|--------|-----------|----------|---------------------------|------------|----------------------------------|---------------|
| 3. 4.  | GS3313GS  | aluminum | geared                    | 32cm/12.6" | 47cm/18.5"                       | 1.09kg/2.4lbs |
| 3. 4.  | GS3513S   | carbon   | rapid                     | 33cm/13.0" | 45cm/17.7"                       | 0.48kg/1.1lbs |
| 5.     | GS5313GS  | aluminum | geared                    | 30cm/11.8" | 47cm/18.5"                       | 1.48kg/3.3lbs |
| 5.     | GS5313LGS | aluminum | geared                    | 75cm/29.5" | 92cm/36.2"                       | 1.97kg/4.3lbs |
| 5.     | GS5513S   | carbon   | rapid                     | 35cm/13.8" | 49cm/19.3"                       | 0.63kg/1.4lbs |
| 5.     | GS5513XLS | carbon   | rapid (telescopic 4 sec.) | 41cm/16.1" | min 67cm/26.4" - max 208cm/81.9" | 0.95kg/2.1lbs |



# Mountaineer tripods

Since Gitzo presented its first carbon-fiber tripod in 1994, the Mountaineer family has been one step ahead in tripod technologies. Uniting lightweight comfort and rigid constructions, Mountaineers have it all. The latest versions feature functions that celebrate fast and easy handling. This includes the smart leg-locking system with stiffer legs, stronger Carbon eXact tubes and the completely redesigned Ground Level Set, which allows photographers to remove the center column effortlessly.



series

## 0.

top leg ø: 21.7mm

The Series 0 Mountaineer tripod is the lightest in the range, but also the shortest in extended height. Recommended for photographers for whom reduced equipment weight is of paramount importance, or for those using only lightweight cameras and lenses. The Series 0 uses Carbon eXact tubes with stiff HM carbon for all leg sections. For significant improvements in rigidity, tube diameters are now greater than on previous Series 0 Mountaineers: at 11.2mm, the thinnest section of the GT0542 is 40% larger than its predecessor. The top casting is also more rigid, and now features 3 leg angle settings.

series

## 1.

top leg ø: 25.3mm

Series 1 Mountaineer is a lightweight, standard height tripod. An excellent choice for photographers on the move, the Series 1 is recommended for DSLRs with 135mm lenses (up to a maximum of 200mm). The Series 1 uses Carbon eXact tubes with stiff HM carbon for all leg sections. For significant improvements in rigidity, tube diameters are now greater than on previous models: at 14.7mm, the thinnest section of the GT1542 is 22.5% larger than its predecessor.

series

## 2.

top leg ø: 29.0mm

Versatile, with a perfect balance of rigidity and reduced weight, Series 2 is the most popular of the Mountaineer tripods. With its newly designed top casting and Carbon eXact tubes, Series 2 is a solid tripod, recommended for DSLRs with 200mm lenses (up to 300mm maximum).

series

## 3.

top leg ø: 32.9mm

Series 3 is the most rigid in the Mountaineer range. Scaled for professional equipment, including medium format cameras and DSLRs with 300mm lens (400mm maximum), the Carbon eXact tubes and new design features of Series 3 Mountaineer tripods offer increased rigidity yet reduced weight.

| series | ref.    | legs tube Ø               | interchangeable feet | ⌋ | ⌋           | ⌋           | ⌋         | ⌋           | ⌋             | max        |
|--------|---------|---------------------------|----------------------|---|-------------|-------------|-----------|-------------|---------------|------------|
| 0.     | GT0532  | 21.7, 18.2, 14.7mm        |                      | 3 | 132cm/52.0" | 108cm/42.5" | 15cm/6.0" | 53cm/ 20.7" | 1.07kg/2.4lbs | 8kg/18lbs  |
| 0.     | GT0542  | 221.7, 18.2, 14.7, 11.2mm |                      | 4 | 137cm/53.9" | 112cm/44.1" | 14cm/5.6" | 48cm/ 18.7" | 1.12kg/2.5lbs | 8kg/18lbs  |
| 1.     | GT1532  | 25.3, 21.7, 18.2mm        | •                    | 3 | 158cm/62.2" | 133cm/52.4" | 17cm/6.5" | 62cm/ 24.5" | 1.33kg/2.9lbs | 10kg/22lbs |
| 1.     | GT1542  | 25.3, 21.7, 18.2, 14.7mm  |                      | 4 | 159cm/62.6" | 135cm/53.1" | 15cm/6.0" | 54cm/ 21.3" | 1.28kg/2.8lbs | 10kg/22lbs |
| 2.     | GT2532  | 29.0, 25.3, 21.7mm        | •                    | 3 | 166cm/65.4" | 138cm/54.3" | 16cm/6.4" | 65cm/ 25.4" | 1.67kg/3.7lbs | 18kg/40lbs |
| 2.     | GT2542  | 29.0, 25.3, 21.7, 18.2mm  | •                    | 4 | 167cm/65.7" | 139cm/54.7" | 15cm/5.9" | 56cm/ 22.1" | 1.68kg/3.7lbs | 18kg/40lbs |
| 2.     | GT2543L | 29.0, 25.3, 21.7, 18.2mm  | •                    | 4 | 179cm/70.5" | 151cm/59.4" | 16cm/6.2" | 61cm/ 23.9" | 1.74kg/3.8lbs | 18kg/40lbs |
| 3.     | GT3532  | 32.9, 29, 25.3mm          | •                    | 3 | 161cm/63.4" | 133cm/52.4" | 16cm/6.5" | 64cm/ 25.1" | 1.88kg/4.1lbs | 21kg/46lbs |
| 3.     | GT3542  | 32.9, 29, 25.3, 21.7mm    | •                    | 4 | 162cm/63.8" | 134cm/52.8" | 15cm/5.9" | 54cm/ 21.4" | 1.86kg/4.1lbs | 21kg/46lbs |
| 3.     | GT3542L | 32.9, 29, 25.3, 21.7mm    | •                    | 4 | 178cm/70.1" | 150cm/59.1" | 16cm/6.1" | 59cm/ 23.4" | 1.95kg/4.3lbs | 21kg/46lbs |

### Mountaineer kit

| series | ref.        | tripod ref. | head ref. | interchangeable feet | ⌋ | ⌋           | ⌋           | ⌋            | ⌋            | max           |            |
|--------|-------------|-------------|-----------|----------------------|---|-------------|-------------|--------------|--------------|---------------|------------|
| 1.     | GK1542-82QD | GT1542      | GH1382QD  |                      | 4 | 171cm/67.4" | 147cm/57.9" | 26.5cm/10.4" | 65cm/25.6"   | 1.78kg/3.9lbs | 10kg/22lbs |
| 2.     | GK2542-82QD | GT2542      | GH3382QD  | •                    | 4 | 180cm/70.9" | 152cm/59.9" | 28cm/10.9"   | 68.5cm/27"   | 2.45kg/5.4lbs | 18kg/40lbs |
| 3.     | GK3532-82QD | GT3532      | GH3382QD  | •                    | 3 | 175cm/68.9" | 147cm/57.9" | 29cm/11.4"   | 76.5cm/30.1" | 2.65kg/5.8lbs | 18kg/40lbs |



# Tripod Accessories

## location shoe

G1586B3

Set of 3 shoes. Fixes to the leg ends of most Gitzo tripods without requiring removal of the original feet.



## extra long spike

G1220.129LB (1 pc)

G1220.129LB3 (set of 3)

Provides a firm footing on soft ground. Compatible with all Gitzo tripods and monopods with a 3/8" thread.



## tripod grease

GSGREASE02

This is the grease we recommended you use each time you clean your Gitzo tripod's leg locks, and it's also what we use in the Gitzo factory during assembly and servicing in order to guarantee that our tripods operate smoothly and that their metal surfaces are protected against excessive wear over the course of their long lives. When used sparingly as recommended, this grease has a special non-sticky formula that won't attract the dust, sand or dirt particles that can dramatically reduce the efficiency and lifespan of the leg locking system. Supplied as two small tubes, each of which contains the correct amount of grease for a complete 4-section tripod.



## big feet

GSF50M (1 pc)

GSF50 (set of 3)

Ultra-stable big feet (diameter 50mm) for solid footing and maximum stability on any surface, from slippery floors to soft sand. The integrated ball allows the rubber to have full contact with the ground regardless of the leg angle. When used on monopods, the ball provides smooth movement, making it easier to follow moving subjects. Compatible with all Gitzo tripods and monopods with a 3/8" thread.



## short spike with rubber foot

GSFSM (short spike + rubber foot 30 and 38mm, 1pc)

GSF30S (short spikes + rubber feet 30mm, set of 3)

GSF38S (short spikes + rubber feet 38mm, set of 3)

The rubber foot is attached to the short spike like a cap, and can be pulled off to use the spike. Compatible with all Gitzo tripods with a 3/8" thread. The new rubber material is very stable even on slippery floors.



## standard rubber feet

GSF25 (diameter 25mm)

GSF33 (diameter 33mm)

Standard feet compatible with all Gitzo tripods with a 3/8" thread. The new rubber material is very stable even on slippery floors. Set of 3.

## photo-video double use spike-rubber feet

GS5030VSF

By simply turning the rubber cups in or out, these feet switch between spikes and rubber feet. Can be fitted to Gitzo tripods with a 3/8" thread. Set of 3.



# Gimbal fluid head

Once again, Gitzo lives up to its reputation as a brand that keeps pushing boundaries. When it comes to heads, the new Fluid Gimbal head makes every movement precise and uninhibited, enabling photographers to capture the most perfect photos and videos.

The new GHFG1 is ideal for wildlife photography and birdwatching, particularly for extensive observation, because it guarantees flawless balance, even with heavy equipment.

This new outstanding head features both modern design and innovative solutions. Clean and harmonic lines, Gitzo's distinctive Noir Décor finish and extreme attention to detail meet the latest technological solution - the fluid

cartridge and fluidity control system - making this head the perfect blend of aesthetic appeal and high performance. The GHFG1's most distinctive functional feature is the fluid cartridge, a technology that comes from the video world and is being applied to a gimbal head for the very first time. The fluid cartridge dampens vibrations and ensures that smooth movement is maintained during observation and shooting, even when manipulating very large lenses. The Fluid Gimbal Head cartridge also features an innovative fluidity control system, the Whip-Pan, which delivers superlative device control during high-speed movements.



| series | ref.  | QR | included plate   | pan  | tilt | pan lock | tilt lock |           |                |             |
|--------|-------|----|------------------|------|------|----------|-----------|-----------|----------------|-------------|
| 2.     | GHFG1 | •  | Arca type (1/4") | 360° | 360° | •        | •         | 24cm/9.4" | 1,35kg/2.97lbs | 8kg/17.6lbs |



# Ball heads

Gitzo's Center Ball Heads are extremely balanced and versatile heads, engineered and developed to be the ideal complements to our top of the range tripods. The completely new range represents the state-of-the-art in the heads' field, focusing on ultimate smoothness

and precision of the movement and locking. Center Ball Heads are a further demonstration of the Gitzo's commitment in research and development, warranty of the attention provided to photographers for equipping them with straightforward and elegant solutions.



# Off center ball heads

Off Center Ball Heads are among the most distinctive and respected products in the Gitzo range. This unique head design allows unsurpassed positioning freedom by offering a range of movement impossible with conventional heads.

The ideal tool for creative photographers who love to explore unique perspectives, for macro shooting and for use with the reversed

column configuration for ground level shooting, Off Center Ball Heads feature separate pan and tilt controls, a graduated base, and ultra-light magnesium castings.

Off Center Ball Heads feature SADL (Spring Assisted Double Lock) and have a PTFE treated ball to maximize both locking power and smoothness of movement.

GH1382QD

GH3382QD

GH4383LR

GH4383QD



GH3750QR

GH5750QR



| series | ref.     | QR | included plate  | pan  | tilt | side tilt | pan lock | ball lock | friction control |             |               |             |
|--------|----------|----|-----------------|------|------|-----------|----------|-----------|------------------|-------------|---------------|-------------|
| 1.     | GH1382QD | •  | GS5370SD (1/4") | 360° | ±40° | +90°/-40° | •        | •         | •                | 11.2cm/4.4" | 0.50kg/1.1lbs | 14kg/31lbs* |
| 3.     | GH3382QD | •  | GS5370D (1/4")  | 360° | ±40° | +90°/-40° | •        | •         | •                | 12.6cm/5.0" | 0.77kg/1.7lbs | 18kg/40lbs* |
| 4.     | GH4383LR | •  | GS5370SD (1/4") | 360° | ±40° | +90°/-40° | •        | •         | •                | 12.5cm/4.9" | 0.9kg/1.98lbs | 30kg/66lbs* |
| 4.     | GH4383QD | •  | GS5370SD (1/4") | 360° | ±40° | +90°/-40° | •        | •         | •                | 12.5cm/4.9" | 0.9kg/1.98lbs | 30kg/66lbs* |

\* Max payload based on JPVAA S102-2015 testing standard

| series | ref.     | QR | included plate | pan  | side tilt | front/back tilt | pan lock | ball lock |             |                |            |
|--------|----------|----|----------------|------|-----------|-----------------|----------|-----------|-------------|----------------|------------|
| 3.     | GH3750QR | •  | GS5370B (1/4") | 360° | +90°      | 360°            | •        | •         | 13cm/5.1"   | 0.79kg/1.74lbs | 8kg/18lbs  |
| 5.     | GH5750QR | •  | GS5370B (1/4") | 360° | +90°      | 360°            | •        | •         | 14.2cm/5.6" | 1kg/2.2lbs     | 12kg/26lbs |





## 2-way fluid head

Gitzo 2 Way Fluid Head provides the highest performance for birdwatchers and digiscopers with medium-size spotting scopes, as well as for wildlife photographers and videographers using premium CSC or DSLR cameras with lenses up to 200mm.

Birdwatching demands specific features of support equipment, but almost all the heads used by birdwatchers are video- or photo-dedicated are usually larger, heavier and more complicated supports than they ideally need. Uniquely, Gitzo 2 Way Fluid Head has been developed to meet a single target: to fully satisfy both birdwatchers and short-medium range wildlife photographers, who are very close in needs.

Gitzo 2 Way Fluid Head is an extremely compact fluid head with a beautiful, ergonomic design. Noir décor reflection-free surfaces offer good camouflage, especially critical for use in wildlife applications. This head offers a complete range of technical features combined with an exceptional size/weight-performance ratio.

The key innovations of this head are the fluid cartridges and the precise inner mechanism. The result is an unconventional head perfectly matched to Carbon Fibre Gitzo tripods – an extraordinary combination of performance and portability, designed to give ultra-stable and precise spotting and shooting.



| series | ref.  | QR | included plate | pan  | tilt      | pan lock | tilt lock | counter balance |            |               |            |
|--------|-------|----|----------------|------|-----------|----------|-----------|-----------------|------------|---------------|------------|
| 1.     | GHF2W | •  | GS5370DR       | 360° | -90°/-60° | •        | •         | •               | 9,5cm/3.7" | 0,59kg/1.3lbs | 4kg/8.8lbs |



## 3-way head

The Gitzo 3 Way Fluid Head is designed to deliver precise and versatile framing for photographers. It is perfect for; Landscape Photographers who require precise framing and fine-tuned compositions.(ie. Horizons) Studio Photographers who images through precise framing. Architectural Photographers who experiment with angles to achieve different and creative perspectives. Offers great working versatility as well as precise framing for creative photography.

Patented retractable handles make it the perfect head to carry on outdoor adventures. Equipped with an independent fluid cartridge for each axis. Ensures the silky smooth and seamless movements without stick-slip. Its ergonomic handles allow accurate and effortless composition.



| series | ref.  | QR | included plate | pan  | tilt      | pan lock | tilt lock | counter balance |             |               |              |
|--------|-------|----|----------------|------|-----------|----------|-----------|-----------------|-------------|---------------|--------------|
| 3.     | GHF3W | •  | GS5370DR       | 360° | -90°/-60° | •        | •         | •               | 11,5cm/4.5" | 0,95kg/2.1lbs | 13kg/28.6lbs |



For over fifty years, Rycote has focused on developing and delivering industry standard microphone shock and wind noise protection, from recording and broadcast studios to the extremes of field production sound. This is not just their speciality - it is their passion.

Rycote has used their many years of engineering knowledge to create the most complete line of specialised microphone accessories available today. Rycote's products and innovations are engineered and rigorously tested to achieve the complex balance of eliminating wind and handling noise, while preserving a microphone's natural frequency response.

Rycote take enormous pride in each and every product, many of which require several hours of hand assembly by their highly trained production team. Some of their exceptionally skilled seamstresses have been with them for decades, and the fruits of their craft are seen on movie sets, in sports stadiums and everywhere else around the globe where professional microphone wind and shock protection is required. A new journey began for Rycote when they recently joined forces with Vitec Imaging Solutions for a long-overdue upscaling of their presence in the imaging and audio accessories market.

Vitec Imaging Solutions' R&D and operational excellence are invaluable assets that Rycote will be able to benefit from in new product solutions, even greater reliability and vastly wider distribution. Rycote continues to design, innovate, and build peerless audio accessories by hand.

## Products:

- Stereo Cyclone
- Cyclone
- Modular Windshield
- BBG Windshield
- Boom Poles
- Shock Mounts inVision Collection
- Studio Shock Mounts
- Classic Softie
- Classic Softie Kits
- Windjammers & Foam
- PCS Quick Release
- PCS Stands & Grips
- Adapters
- Portable Recorder Kits
- Lavalier Microphones



# Cyclone

Quick. Clear. Consistent.

Cyclone – the premium microphone windshield system with ground breaking advancements for all-round performance excellence.

The flagship Rycote Cyclone range features next-generation wind and handling noise isolation for discerning audio professionals. Truly evolutionary, this durable windshield system possesses outstanding, consistent performance while being easy to maintain as it does not use fur.

All Cyclone models feature our advanced 3D-Tex® material. This provides a neutral appearance and superior performance over standard basket solutions, with excellent acoustic transparency and superb attenuation of wind-noise. Covering a lightweight yet durable chassis, Cyclone models are designed to withstand the extremes of the field for reliable, daily use – to deliver the consistent results location audio professionals depend on.



### Cyclone Kit, Large RYC089101

Mic compatibility: Length: 250mm-280mm, Diameter: 19-25mm

### Cyclone Kit, Medium RYC089102

Mic compatibility: Length: 174mm-255mm, Diameter: 19-25mm

### Cyclone Kit, Small (XLR) RYC089103

Mic compatibility: Length: 75mm-160mm, Diameter: 19-25mm

# Stereo Cyclone

Performance excellence in every detail.

The Stereo Cyclone range features a comprehensive selection of professional windshield kits, designed for the popular stereo techniques, such as X/Y, Mid-Side and Double Mid-Side. As well as models designed for Single Mic and Ambisonic mic applications.

Each model has been individually designed to perfectly complement specific, popular stereo microphone combinations. Whether it's for production sound, broadcast, audio for gaming or wildlife recording – if you use stereo recording to create directionality, perspective, space, atmosphere and realism – there's a Stereo Cyclone model that's perfect for you!



### Stereo Cyclone MS KIT 4 RYC089113

Mid: Sennheiser MKH 40 or 50, Side: Sennheiser MKH 30

### Stereo Cyclone MS KIT 5 RYC089114

Mid: Schoeps CMC MK 4 or 41, Side: Schoeps CMC MK 8

### Stereo Cyclone AMBISONIC 1 RYC089140

Mic: Sennheiser AMBEO

### Stereo Cyclone XY KIT 1 RYC089126

Left: Sennheiser MKH 8040, Right: Sennheiser MKH 8040



# Modular Windshield

The professional standard

Rycote windshield / suspension systems are the original, iconic systems used by audio professionals around the world since 1969. Rycote has applied numerous engineering developments, evolving this system to maintain its status as the professional, industry standard over the past decades. The Modular Windshield System offers various levels of wind protection (use with or without Windjammer) and superb shock isolation. Available as a fully complete, comprehensive kits, Modular components can also be purchased for retro-fitting - to accommodate different length or diameter microphones.



### Modular Windshield 416 Kit \* RYC010324

Perfect for the Sennheiser MKH 416

### Modular Windshield WS 4 Kit RYC086001

Mic compatibility: Length: 211mm-280mm, Diameter: 19-34mm

### Modular Windshield WS 3 Kit RYC086002

Mic compatibility: Length: 161mm-210mm, Diameter: 19-25mm

### Modular Windshield WS 2 Kit RYC086003

Mic compatibility: Length: 121mm-160mm, Diameter: 19-25mm

### Modular Windshield WS 1 Kit RYC086004

Mic compatibility: Length: 120mm, Diameter: 19-25mm

### Modular Windshield WS 6 Kit RYC086006

Mic compatibility: Length: 351mm-400mm, Diameter: 19-34mm

### Modular Windshield WS 8 Kit RYC086008

Mic compatibility: Length: 466mm-540mm, Diameter: 19-34mm

### Modular Windshield WS 295 Kit\* RYC086009

Mic compatibility: Length: 210mm-255mm, Diameter: 19-25mm

\* Most Popular Models

### Modular Windshield WS 10 Kit RYC086010

Mic compatibility: Length: 70mm, Diameter: 19-25mm

### Modular Windshield WS 8J Kit RYC086061

Mic compatibility: Length: 465mm, Diameter: 19-25mm

# BBG Windshield

Wind attenuation properties of a full windshield in a small package

Perfect for short microphones, the BBG Windshield is suitable for low-profile boom applications as well as for use in hand-held operations and interviews. Designed to accommodate not only cylindrical microphones, it also accommodates microphones with bulbous windscreens where the maximum head diameter is 80 mm. The BBG Windshield is also an excellent solution for ORTF applications.



### 20MM BBG Windshield RYC011001

For mics with 19 to 20mm shank diameter

### 21MM BBG Windshield RYC011007

For mics with 21mm shank diameter

### 22MM BBG Windshield RYC011002

For mics with 22mm shank diameter

### 25MM BBG Windshield RYC011003

For mics with 25mm shank diameter

# Mic Boom Poles

Extend with Precision

With the combined expertise of Rycote in professional sound recording and Vitec's carbon fibre technology used in their market-leading Gitzo tripods, Rycote has produced a perfectly balanced and precise tool for the boom operator.



### Mic Boom Small RYC190001

Min length: 57 cm/22.5in  
Max Length: 200 cm/78.8in  
Weight: 0,48 kg/1.06lbs

### Mic Boom Medium RYC190002

Min length: 83 cm/32.6in  
Max Length: 330 cm/130in  
Weight: 0,65 kg/1.43 lbs

### Mic Boom Large RYC190003

Min length: 100 cm/39.4in  
Max Length: 420 cm/165.3in  
Weight: 0,78 kg/1.72 lbs



# Shock Mounts

## InVision® - Industry-leading shock and handling isolation

InVision Broadcast & Film Suspensions provide unparalleled protection against shock, vibration, and handling noise for miniature, probe, handheld, and shotgun microphones. Utilising Rycote's exclusive Lyre technology, these virtually unbreakable shock-mounts are designed with an integral cable clamp to isolate the microphone from cable and stand-borne noise.

Rycote has designed the INV-6 HEAVY and INV-7HG MKIII shock mounts for use with slip-on windshields. Ideal for use with Super-Softie, Classic-Softie and BBG Windshield models, these robust shock mounts provide excellent isolation for boom pole and stand mounting applications.



(RCY041107)



(RCY041118)

### Shock Mount INV-6 RYC041106

Mic compatibility:  
Max length: 120mm,  
Diameter: 19-25mm

### Shock Mount INV-7 RYC041107

Mic compatibility:  
Max length: 250mm,  
Diameter: 19-25mm

### Shock Mount INV 7 HG MK III RYC041118

Mic compatibility:  
Max length: 250mm,  
Diameter: 19-34mm

### Shock Mount INV-6 HEAVY RYC041117

Mic compatibility:  
Max length: 120mm,  
Diameter: 19-25mm



## INV-Lite

The INV-Lite has been designed specifically for interior boom use with a foam windscreen. It offers a more focused solution for smaller, lighter shotgun microphones, allows full placement of a 12cm SGM foam to provide basic wind and plosive protection indoors, and provides super-fast access to the microphone via the revolutionary cam-lever clamp system.

### INV-LITE 21 RYC041135

Mic compatibility:  
Max length: 210mm,  
Diameter: 21mm,  
Max weight: 120g

### INV-LITE 19 RYC041136

Mic compatibility:  
Max length: 210mm,  
Diameter: 19mm,  
Max weight: 120g



## Camera Mic Shock Mounts

Professional shock and handling isolation for camera mounted microphones. Rycote offers InVision Video and Softie Lyre Mount solutions specifically designed for mounting professional microphones to cameras with industry-leading shock mount technology.

### INV VIDEO HOT SHOE RYC042901

Mic compatibility:  
Max length: 300mm,  
Diameter: 19-25mm

### INV ON CAMERA RYC041138

Mic compatibility:  
Max length: 300mm,  
Diameter: 19-25mm



(RYC033702)

### InVision Softie Lyre Mount w/ Pistol Grip RYC033702

Mic compatibility:  
Diameter: 19-25mm

### 12CM Classic-Softie Camera Kit RYC116010

Mic slots no further than 12cm from front, diameter 19-22mm

### 15CM Classic-Softie Camera Kit RYC116011

Mic slots no further than 15cm from front, diameter 19-22mm

### 18CM Classic-Softie Camera Kit RYC116012

Mic slots no further than 18cm from front, diameter 19-22mm



# Studio Shock Mounts

## Added versatility for the studio

Rycote patented Lyre® technology is the most advanced shock mount and suspension technology used in field applications today. Rycote has also applied this expertise to develop the InVision® Studio product line - bringing a new level of performance, versatility, value, and durability to studio, 'live' sound, broadcast and installed applications.

This broad range of solutions includes the Universal Studio Mounts ('USM') for side-address, studio condenser microphones and InVision Studio Suspensions for probe, hand-held, miniature and shotgun microphones.



## Say goodbye to expensive, fragile elastic suspensions

The USM utilises specially designed clips with Rycote patented Lyre® technology. Made from robust Hytrel thermoplastic, the USM will never sag or need rethreading. This virtually indestructible, innovative design provides an additional 12 dB of isolation, compared to conventional elastic suspensions.

## InVision Universal Studio Mount

### For side-address microphones

USM - the Universal Studio Mount - is a purpose-built shock mount designed to fit practically any side-address microphone.

The unparalleled flexibility of the InVision USM allows for unprecedented fast setup in studio and 'live' applications. Its unique, adjustable, universal locking system can be quickly adjusted to securely fit a wide range of microphones.

With just a handful of models, the InVision USM range covers a huge range of microphones, of various diameters, with models that provide peak performance for both lighter and heavier side-address mics alike.

### InVision USM RYC044901

Mic compatibility:  
Diameter: 18-55mm,  
Max length: 300mm,  
Max Weight: 750g (vertical) / 500g (horizontal).

### InVision USM Studio Kit RYC045002

Mic compatibility:  
Diameter: 18-55mm,  
Max length: 300mm,  
Max Weight: 750g (vertical) / 500g (horizontal).

### InVision USM-L RYC045003

Mic compatibility:  
Diameter: 18-55mm,  
Max length: 300mm,  
Max Weight: 750g (vertical) / 250g (horizontal).





# Slip-On Systems

## The original slip-on windshield Classic-Softie®

The genuine Rycote Classic-Softie® set the standard for slip-on wind protection, offering proven, cost-effective wind protection at a moment's notice. Advanced materials, adhesives and assembly techniques all combine to make "the Softie" an extremely tough product that provides excellent wind protection to withstand the harshest environments.

Providing lightning-fast wind protection, the Softie is designed for modern day ENG and location recording. Specially designed acoustic foam and synthetic fur achieve up to 25 dB of wind-noise reduction without any adverse effect on high frequencies.

**5cm Classic-Softie (19/22)**  
RYC033012

Mic slots no further than 5cm from front, diameter 19-22mm

**12cm Classic-Softie (19/22)**  
RYC033032

Mic slots no further than 12cm from front, diameter 19-22mm



**15cm Classic-Softie (19/22)**  
RYC033042

Mic slots no further than 15cm from front, diameter 19-22mm

**18cm Classic-Softie (19/22)**  
RYC033052

Mic slots no further than 18cm from front, diameter 19-22mm



**15cm Classic-Softie Kit (19/22)**  
RYC033342

Mic slots no further than 15cm from front, diameter 19-22mm

## Classic-Softie® Kits

Perfect for boom mounting or hand-held recording, the Classic-Softie Kit has all the essential components necessary for modern day ENG and location recording. The Classic-Softie is the simplest, most robust & cost-effective windshield in our range.

### The Classic-Softie Kits include:

- Classic-Softie® Windshield
- InVision® Softie Lyre Mount with Pistol Grip
- 40cm XLR-3F/3M cable (4.8mm)
- Brush for fur maintenance

**18cm Classic-Softie Kit (19/22)**  
RYC033352

Mic slots no further than 18cm from front, diameter 19-22mm

**\*Perfect For\* Softie Kit, NTG**  
RYC033394

Perfect for the Rode NTG 1,2,3,4,4+

## Mic foams

Engineered exclusively for Rycote, our high quality foams provide up to 20 dB wind noise attenuation and excellent resistance against the damaging effects of moisture and UV light. Windjammers for Foams Our SGM foams, and Large Diaphragm Foam Windshields are available with a Rycote Windjammer for high-wind situations, providing an additional 12 dB wind-noise attenuation. These Foam / Windshield combos can be purchased in convenient kits or as separate components.

**18cm ME66 SGM Foam & Windjammer**  
RYC055210

Mic slots no further than 18cm from front.

**18cm SGM Foam & WJ (19/22)**  
RYC055208

Mic slots no further than 18cm from front, diameter 19-22mm



**Windjammer WJ 1**  
RYC021501

Suitable for Modular Windshield 1

**Windjammer WJ 4**  
RYC021504

Suitable for Modular Windshield 4

## Modular Windjammer

Originally developed by Rycote, the Windjammer is a high-quality, synthetic fur-cover that provides the highest possible protection against extreme wind-noise. When using a Windjammer fitted over a Windshield, up to 50 dB of wind-noise attenuation can be achieved, producing excellent standard audio recordings. Made from materials specially designed for wind-noise isolation, the Windjammer has virtually no adverse effect on high frequencies.

**Windjammer WJ 2**  
RYC021502

Suitable for Modular Windshield 2

**Windjammer WJ 295**  
RYC021510

Suitable for Modular Windshield 295

**Windjammer WJ 3**  
RYC021503

Suitable for Modular Windshield 3

**BBG WJ**  
RYC021801

Suitable for all mono BBG



# Professional Connection System

## Easy, Solid and Noise-free Quick Release

The original PCS solves a multitude of problems with a unified, professional and sturdy quick-release system that allows for an instant, one-handed, quick connect/disconnect of all types of microphones to a boom pole or fixture. Rycote has built on the PCS Boom Connector's success to create a complete system for quicker, more secure, and less complicated workflow than sound professionals have been able to enjoy so far. Rycote has developed the new system in response to the clear need for assisting production sound mixers, boom ops, sound recordists and audio engineers - whether in the field, studio, theatre, or at live events - in achieving a quick and simple workflow.



**PCS-Boom**  
RYC185801

**PCS-Lite 3/8"**  
RYC185802

**PCS-Lite 5/8"**  
RYC185812

**PCS-Spigot**  
RYC185803

**PCS-Organizer**  
RYC185800

**PCS-Utility**  
RYC185804

**PCS-Utility Half Coupler Kit Small**  
RYC185809

**PCS-Utility Half Coupler Kit Large**  
RYC185810

**Half Coupler Small 32-35mm w/3/8" Bolt**  
RYC185806

**Half Coupler Large 48-51mm w/3/8" Bolt**  
RYC185811

**Pair 3/8" Male Tips for PCS**  
RYC185805

**Pair 5/8" Male Tips for PCS**  
RYC185813

## Stand & Grips

Professionals will benefit from the extreme flexibility of positioning mics and accessories in the exact location they should be, but quicker and easier than ever before. Solid, versatile and durable even under intense usage the new range of Stands & Grips is ideal for broadcasters and music industry professionals looking for a reliable microphone placement system. The combination with the PCS quick-release system increases speed and convenience creating a matchless attachment solution



**PCS-Artic Arm**  
RYC500100

**PCS-Artic Arm w/ Super Clamp**  
RYC500101

**PCS-Artic Arm Micro Kit**  
RYC500111

**PCS-Cobra Arm 3/8"**  
RYC500102

**PCS-Stand Base 3/8" PCS-U Kit**  
RYC500105

**PCS-Sound Stand Mini 3/8"**  
RYC500108

**PCS-Sound Stand 3/8"**  
RYC500104

**PCS-Sound Stand 3/8" PCS-U Kit**  
RYC500106

**PCS-Stand Base 3/8"**  
RYC500103

**PCS-Stand Base Mini**  
RYC500107



**HOT SHOE TO 3/8" ADAPTOR**  
RYC037302

Hotshoe to 3/8" adaptor. This adaptor allows the mounting of a professional shockmount on a camera with "Hot Shoe" receptacle.



**20 CM HOT SHOE EXTENSION 2 X 3**  
RYC037701

Ideal to mount a pair of microphones on a mic stand (3/8"). The Hot Shoe Extension allows you to fit multiple attachments such as lights and additional mics to your single hot shoe on your camera/camcorder.



# Portable Recorder Solutions

## The right tools to make your next recording shine

Whether capturing broadcast news, documentary or your next podcast, Rycote® has the right tools to make your next recording shine.

A fantastic compact solution, standalone portable audio recorders with on-board microphones are incredibly popular. There are dozens of portable recorder models on the market for 'field recording', and Rycote has a range of products to provide the all-important wind and handling protection.

Rycote Portable Recorder Suspensions, Mini Windjammer® and all-in-one Kits really are essential items to help you capture the best possible audio with your portable recorder, whatever the application!



**AUDIO KIT - ZOOM H4N**  
RYC046001

**AUDIO KIT HD - ZOOM H6**  
RYC046023

**AUDIO KIT - SONY PCM-D100**  
RYC046024

**AUDIO KIT - ZOOM H5**  
RYC046025

## Mini Windjammer® for Portable Recorders

The Mini Windjammer is made from the same tried and tested material that we use for our acclaimed professional 'full size' wind-protection products. Available for most of the popular contemporary portable recorder models, the slip-on Windjammer provides excellent wind protection for professional-quality results in a wealth of outdoor news, documentary and podcasting applications.

**MWJ ZOOM H4N**  
RYC055438

**MWJ ZOOM H5 MINI WJ**  
RYC055462

**MWJ TASCAM DR-40**  
RYC055444

**MWJ ZOOM H6 MINI WJS**  
RYC055454

**MWJ RODE VIDEOMIC NTG**  
RYC055481



# Lavalier Solutions

## Versatility for discrete and hidden mic placement.

Simple solutions for Lavalier microphones

'Consumables', 'disposables', 'expendables'... they go by many names and they are those single or limited use items that sound pros use on a daily basis with lavalier mics. Whether its for sticking, fixing, hiding or protecting lavalier mics, we know that these little products are crucial for getting the job done!

## Essentials Original

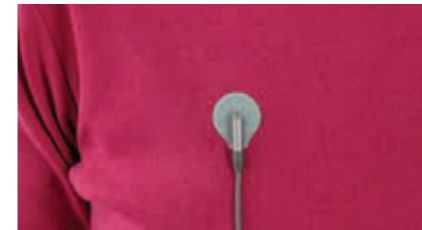

### Stickies, Original

Stickies are double-sided, hypoallergenic, adhesive pads used to affix lavalier microphones directly onto skin or on top of clothing. The soft fabric sandwiched between the two adhesive pads prevents the adhered mic from creaking due to skin or clothing movement. Included with Overcovers and Undercovers, Stickies are designed to remain secure when attached to a dry surface and are intended to be discarded after use.

**Pack of 30 stickies**  
RYC065506

**Pack of 100 stickies**  
RYC065530

**Roll of 500 stickies, 23mm diameter**  
RYC065567

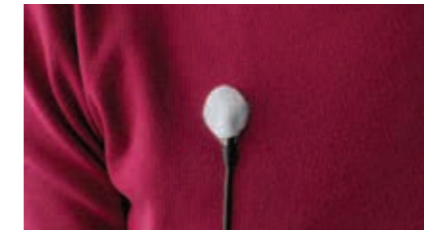

### Undercovers, Original

Undercovers are the perfect solution to completely hide lavalier microphones. Used with the included Stickies, these soft, fabric discs are designed to minimize the sound of clothing movement while providing protection from light wind.

**Pack of 30 Undercovers, black**  
RYC065101

**Pack of 30 Undercovers, grey**  
RYC065102

**Pack of 30 Undercovers, white**  
RYC065103

**Pack of 30 undercovers, mix colours**  
RYC065504

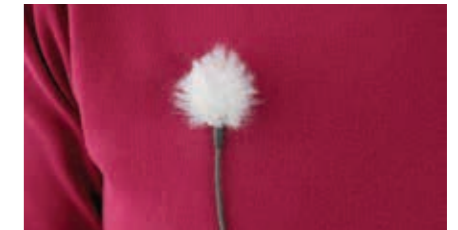

### Overcovers, Original

Overcovers use Rycote exclusive fur technology, providing excellent wind-noise protection for lavalier microphones. They consist of discreet, fur Windjammer® and Stickies. With a Stickie affixed to clothing or skin, a fur Windjammer disc is a fixed over the top of a lavalier microphone.

**Bulk quantities of 25 packs**  
RYC065508

**Pack of 6 fur overcovers mix color / 30 stickies**  
RYC065505

**Pack of 6 fur overcovers black / 30 stickies**  
RYC065520

## Essentials Advanced

The Stickies Advanced further improve usability, quickness and microphone fitting. The double-sided, hypoallergenic, adhesive pads are integrated with soft fabric to prevent the rustling sounds due to skin or clothing movement. Thanks to the single cut out layout combined with the easy peel-off system the sound professionals can move quicker on set. The range is made of Round, O's and Squared formats. The Squared is perfect for use with Sanken RM-11 and for general cable management on radio mics, the Round with larger diameter compared to the Original (23mm vs 20mm) is perfect for use with the ever-popular DPA concealers while the O's format allow wind protection on DPA Concealers, or folded-over with Overcovers.



**Pack of 100 stickies advanced, 20mm squared**  
RYC066329

**Pack of 100 stickies advanced, 23mm O's**  
RYC066328

**Pack of 100 stickies advanced, 23mm round**  
RYC066327

## Lavalier Windjammer

Perfect for use in windy outdoor conditions

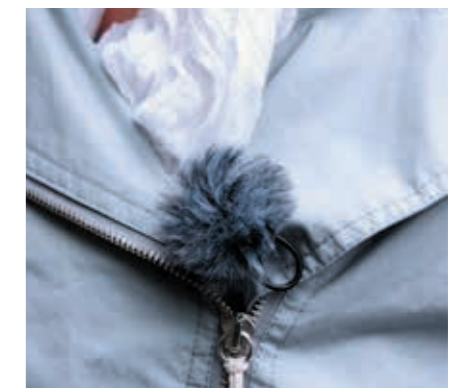

**Black Lavalier Windjammer**  
RYC065501

**Grey Lavalier Windjammer**  
RYC065502



Lastolite™  
By  
Manfrotto

Lastolite By Manfrotto is one of the world's leading manufacturers of backgrounds and lighting control systems used extensively by the world's most accomplished image makers and content creators. Established in 1978 with just one product, the original pop-up reflector, the company now boasts a comprehensive market leading range of over 50 different product families.

Primarily focused on image makers who are regularly on the move, all Lastolite By Manfrotto products – whether it be a small 30cm reflector panel or the renowned 4m wide Chroma Key background system – are each cleverly designed to fold down to an extremely compact size for ultimate portability, whilst also being impressively quick to assemble once at the shoot location.

Designed and manufactured in the UK, Lastolite By Manfrotto has become known for their innovative design, high-quality manufacturing processes and ultimate reliability in the field. Regularly referred to as the 'trusted' brand for professionals, they make products that perform to the highest standards, even in the most demanding situations. Innovation excellence sets Lastolite By Manfrotto apart from its competitors, resulting in a number of active product patents and registered designs.

Whether setting-up a small home studio, a workplace studio or a more complex professional studio, shooting stills or moving images or creating live broadcasts, Lastolite By Manfrotto provides all the key lighting control and background solutions to build a studio that delivers professional results.

## Products:

Reflectors & Diffusers  
Colour and Exposure Control  
Chroma Key Backgrounds  
Portable Backgrounds



# Reflectors & Diffusers

## HaloCompact Reflector and Diffuser

The HaloCompact boasts a patent pending design concept that makes the everyday reflector and diffuser panel even more portable than ever!

Unlike many traditional reflector/diffuser panels that incorporate a steel rim pop up design, the 82cm (32") HaloCompact is constructed using Lastolite By Manfrotto's new innovative RapidExoframe™ technology. The collapsible lightweight aluminium frame quickly slots together and the reflector or diffuser fabric simply clips onto the frame. The cleverly designed RapidExoframe™ construction allows the frame to breakdown into small multiple sections and along with the folded fabric packs into a carry case measuring only 6.5 x 27 x 6.5cm (2.5" x 10.5" x 2.5") weighing only 390g (reflector and case). The ultra-compact folded dimensions make the Halo Compact the perfect 'always with you' solution for Imagemakers on the move.

The HaloCompact also features an ergonomically designed handle so it can easily be held and accurately positioned with one hand. The handle also incorporates a very useful 1/4" thread (plus a 1/4" to 1/4" adaptor), enabling it to be easily attached to various different support systems, to offer secure positioning further away from camera position.

### Features and Benefits

- Ultra compact when folded down
- Weighs only 390g
- Incorporates a 1/4" thread in the handle
- Fits easily in a camera bag

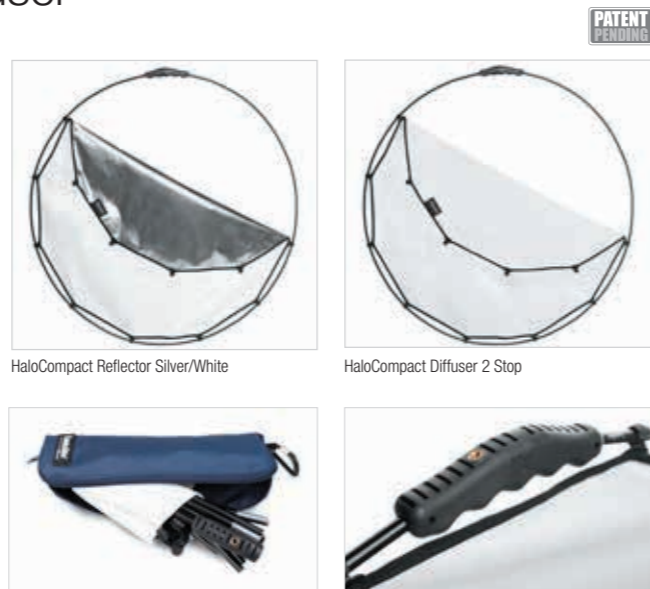

HaloCompact Reflector Silver/White

HaloCompact Diffuser 2 Stop



Ergonomically designed handle with useful 1/4" thread

### Specifications

| HaloCompact 82cm (32")        | Code      |
|-------------------------------|-----------|
| Reflector Silver/White        | LL LR3300 |
| Reflector Sunlite/Soft Silver | LL LR3310 |
| Diffuser 2 Stop               | LL LR3301 |
| Diffuser Soft Silver          | LL LR3320 |

| HaloCompact Covers 82cm (32")       | Code      |
|-------------------------------------|-----------|
| Reflector Cover Silver/White        | LL LR3302 |
| Reflector Cover Sunlite/Soft Silver | LL LR3311 |
| Diffuser Cover 2 Stop               | LL LR3303 |
| Diffuser Cover Soft Silver          | LL LR3321 |

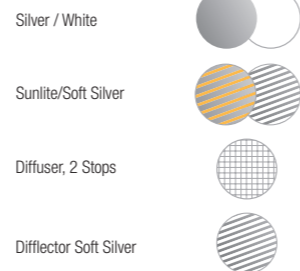

With HaloCompact Diffuser



Without HaloCompact Diffuser

## Skylite Rapid

The Skylite Rapid is the go to solution for location imagemakers who need to diffuse or reflect their light source in the most demanding situations. The Skylite Rapid's lightweight, rapid assembly, collapsible aluminium rigid frame offers ultimate stability even in windy conditions, whilst the clip on covers simply clip in place and offer a complete range of diffusion and reflective surfaces.

The Skylite Rapid frames, covers and accessories are all available separately, so you can mix and match as you choose. For greater value, kits are also available, which collapse down into a neat, compact and very portable rigid carry case.

Note: All Skylite frames are compatible with the original Skylite covers and Skylite Rapid covers.

### Features and Benefits

- Lightweight Aluminium frame
- Resistant to rust so ideal for outdoor use
- Internal elasticated cord running through
- Rapid clip on covers
- Kits include rigid carry case

### Specifications

| Skylite Rapid Covers | Small Covers<br>1.1m x 1.1m<br>(3'6" x 3'6")<br>Code | Medium Covers<br>1.1m x 2m<br>(3'6" x 6'6")<br>Code | Large Covers<br>2m x 2m<br>(6'6" x 6'6")<br>Code | Midi Covers<br>1.5m x 1.5m<br>(5' x 5')<br>Code | Extra Large Covers<br>3m x 3m<br>(10' x 10')<br>Code |
|----------------------|--|---|--|---|--|
| Black / White        | LL LR81121R  | LL LR81221R   | LL LR81521R                                      | LL LR82221R                                     |  |
| Sunfire / White      | LL LR81106R  | LL LR81206R   |  | LL LR82206R                                     |  |
| Silver / White       | LL LR81131R  | LL LR81231R   | LL LR81531R                                      | LL LR82231R                                     |  |
| 1.25 Stop Diffuser   | LL LR81107R  | LL LR81207R   | LL LR81507R                                      | LL LR82207R                                     | LL LR83307R*   |
| 0.75 Stop Diffuser   | LL LR81101R  | LL LR81201R   | LL LR81501R                                      | LL LR82201R                                     | LL LR83301R  |
| Black Velour         | LL LR81102R  | LL LR81202R   |  | LL LR82202R                                     | LL LR83302R  |

\*The 1.25 stops is manufactured using two panels with a single seam running through the centre of the diffuser joining the panels.

| Skylite Rapid Frames            | Weight        | Size                      | Code     | Skylite Rapid Kits            | Silver/White Reflector | 1.25 Stop Diffuser | Frame | Rigid Case | Code         |
|---------------------------------|---------------|---------------------------|----------|-------------------------------|------------------------|--------------------|-------|------------|--------------|
| Skylite Rapid Frame Small       | 1.1kg (2.4lb) | 1.1m x 1.1m (3'6" x 3'6") | LL LR811 | Skylite Rapid Small Kit       | 1                      | 1                  | 1     | 1          | LL LR81143RC |
| Skylite Rapid Frame Medium      | 1.6kg (3.5lb) | 1.1m x 2m (3'6" x 6'6")   | LL LR812 | Skylite Rapid Medium Kit      | 1                      | 1                  | 1     | 1          | LL LR81243RC |
| Skylite Rapid Frame Midi        | 1.5kg (3.3lb) | 1.5m x 1.5m (5' x 5')     | LL LR815 | Skylite Rapid Midi Kit        | 1                      | 1                  | 1     | 1          | LL LR81544R  |
| Skylite Rapid Frame Large       | 2.1kg (4.6lb) | 2m x 2m (6'6" x 6'6")     | LL LR822 | Skylite Rapid Large Kit       | 1                      | 1                  | 1     | 1          | LL LR82243RC |
| Skylite Rapid Frame Extra Large | 3kg (6.6lb)   | 3m x 3m (10' x 10')       | LL LR833 | Skylite Rapid Extra Large Kit | 1                      | 1                  | 1     | 1          | LL LR83344R  |



- Silver / White
- Black / White
- Sunfire / White
- Diffuser 0.75 Stop
- Diffuser 1.25 Stop
- Black Velour



LL LA8446 Skylite Rapid Griphead



The Skylite Rapid cover simply clips to the frame



Skylite Rapid Kit



Skylite Rapid Rigid Case





# Colour and Exposure Control

## EzyBalance

PATENTED

The EzyBalance is a handy double-sided 'pop up' 18% grey/white card, which simplifies the complex technical issues surrounding exposure and colour correction when working in different lighting conditions.

A unique focusing target enables the camera to focus on the card and take the necessary readings. A waterproof version is also available for scuba divers. Available in 3 sizes.

### Features and Benefits

- Colour correction, pre and post capture
- Exposure control, pre and post capture
- Accurate colour rendition
- Collapsible, durable and cleanable
- Double sided
- Unique focusing target
- Collapses to a third of its original size

### Specifications

| EzyBalance     | Code      |
|----------------|-----------|
| 30cm (12") 18% | LL LR1250 |
| 50cm (20") 18% | LL LR2050 |
| 75cm (30") 18% | LL LR3050 |



EzyBalance used to correct the light on the subject from 'Daylight' LED Key light and create a warm light effect from the Tungsten light source behind.



EzyBalance 18%



## StudioLink Swatches



Chroma Key Green



Chroma Key Blue

## StudioLink

The StudioLink Background is a unique modular chroma key background system for use in the studio or out on location. Once assembled, multiple 3 x 3m (10' x 10') StudioLink screens can be joined together using the StudioLink Chroma Key Connection Kit (available separately) to form various configurations; side by side in a straight line or as a curvature up to the point of creating a full 360 degree enclosure. In addition, screens singularly or side-by-side can be rigged (using standard grip equipment) one above the other to create a second tier of screens.

### Features and Benefits

- Reversible
- Chroma Key rim tape as standard
- Crease resistant fabric
- Fast to set up and dismantle
- For inside and outside use
- Collapses to a third of its original size

### Specifications

| StudioLink                        | 3m (10')   |
|-----------------------------------|------------|
| Chroma Key Green Screen Kit       | LL LR83350 |
| Chroma Key Blue Screen Kit        | LL LR83352 |
| <b>StudioLink Covers</b>          |            |
| <b>3m (10')</b>                   |            |
| Chroma Key Green Cover            | LL LR83351 |
| Chroma Key Blue Cover             | LL LR83353 |
| <b>StudioLink Connection Kits</b> |            |
| <b>3m (10')</b>                   |            |
| Chroma Key Green Connection Kit   | LL LR83354 |
| Chroma Key Blue Connection Kit    | LL LR83355 |
| Chroma Key Green Connection Kit   | LL LR8334  |



## StudioLink Accessories

### Specifications

#### StudioLink Accessories

|                                 |           |
|---------------------------------|-----------|
| Chroma Key Green Connection Kit | LL LR8334 |
| Aluminium Frame Support Kit     | LL LA8450 |
| Skylite Rapid Griphead          | LL LA8446 |



Chroma Key Green Connection Kit LL LR8334



Aluminium Frame Support Kit LL LA8450 (sand bag not included)



Skylite's special griphead allows it to be fixed to stands and tilted as required. LL LA8446



# Chroma Key Backgrounds

## Panoramic Chroma Key Backgrounds

The Panoramic background is one of our widest, crease free textile surfaces. It features a collapsible three panel aluminium framework, creating a useful self-supporting wraparound structure. The Chroma Key Green fabric cover simply clips to the framework. The background folds down neatly into its own case and fits easily into a car.

### Features and Benefits

- Up to 4m (13') wide and 2.3m (7'5") high
- Self-supporting
- Weighs only 9kg (19.8lb)
- Packs into a 100cm x 30cm x 35cm (39" x 12" x 13.5") bag

### Specifications

| Panoramic Background 4m (13')                                    | Code      |
|--|-----------|
| Panoramic Background - Chroma Key Green                          | LL LB7622 |
| Panoramic Background - Chroma Key Blue                           | LL LB7943 |
| Panoramic Background Cover - Chroma Key Green                    | LL LB7626 |
| Panoramic Background Cover - Chroma Key Blue                     | LL LB7963 |
| Panoramic Background Connection Kit 2.3m (7'5") Chroma Key Green | LL LB7945 |
| Panoramic Background Connection Kit 2.3m (7'5") Chroma Key Blue  | LL LB7944 |

| Panoramic Background Accessories | Code      |
|----------------------------------|-----------|
| Aluminium Frame Support Kit      | LL LA8450 |



## Panoramic Chroma Key Green Swatch



Chroma Key Green

Chroma Key Blue



## Chroma Key Collapsible Backgrounds

A range of collapsible, reversible, plain coloured textile backgrounds. Available in different sizes, a simple solution for flat plain coloured backgrounds, the seamless paper effect but in a collapsible portable format! Two great backgrounds in one with a pop up construction that provides today's image makers with a truly portable solution for easy transportation. Available in Chroma Key green and Chroma Key blue.

### Features and Benefits

- Crease resistant
- Chroma Key rim tape
- Collapses to a third of its original size
- Available in green and reversible blue/green
- Comes with carry case

### Specifications

| Chroma Key Collapsible Background | Size                   | Code      |
|-----------------------------------|------------------------|-----------|
| Chroma Key Blue/ Green Reversible | 1.5m x 1.8m (5' x 6')  | LL LC5687 |
|                                   | 1.8m x 2.1m (6' x 7')  | LL LC5987 |
|                                   | 1.8m x 2.1m (6' x 7')  | LL LC5981 |
| Chroma Key Green                  | 1.8m x 2.1m (6' x 7')  | LL LC5981 |
|                                   | 1.8m x 2.75m (6' x 9') | LL LC6981 |



## Chroma Key Collapsible Swatches



Chroma Key Green

Chroma Key Blue



Magnetic Background Support LL LB1120

Magnetic Background Support LL LB1120





# Portable Backgrounds

## Vintage Collapsible Backgrounds

The vintage collapsible backgrounds offer a range of versatile subtly textured surfaces, great for interview style filming. These 1.5 x 2.1m (5' x 7') reversible backgrounds provide a very fashionable, timeless hand painted look that subtly complements the chosen subject. Two great backgrounds in one with a collapsible pop up construction that provides today's image-makers with a truly portable solution for easy transportation.

### Features and Benefits

- Timeless hand painted look
- Subtle textured surface
- Reversible
- 6 different colour tones
- Collapses to a third of its original size
- Comes with carry case

### Specifications

**Vintage Collapsible Backgrounds**      **1.5 x 2.1m (5' x 7')**

|                       |             |
|-----------------------|-------------|
| Tobacco/Olive         | LL LB5705   |
| Smoke/Concrete        | LL LB5745   |
| Joe McNally Ironworks | LL LB5750JM |
| Ink/Sage              | LL LB5720   |
| Walnut/Pewter         | LL LB5721   |
| Aubergine/Crimson     | LL LB5722   |



Magnetic Background Support LL LB1120

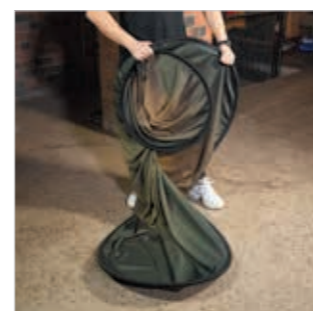

Tobacco/Olive LL LB5705

Some camera sensors may interpret the colours used on our printed backgrounds differently.

## Vintage Collapsible Background Swatches

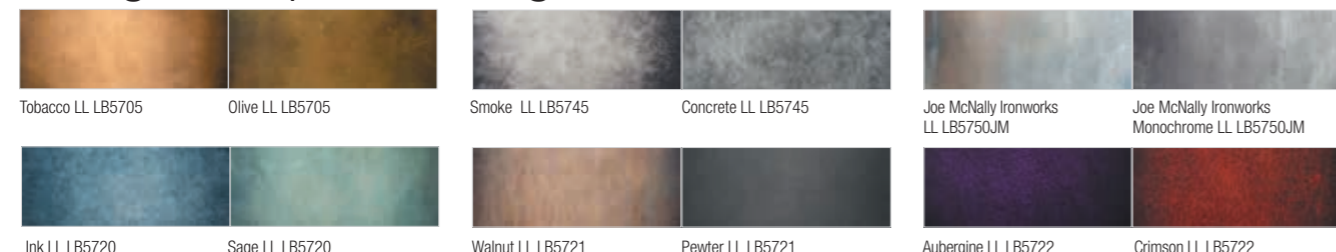

## EzyFrame

The EzyFrame Vintage Background 2 x 2.3m (6'7" x 7'5") is a large format collapsible background concept offering a much larger shooting area for our highly successful vintage textured background surfaces, currently available as 1.5 x 2.1m (5' x 7') collapsible 'pop-up' style backgrounds. The extra width and height combined with the squarer format offers a substantially increased surface area allowing the photographer to pose multiple subjects and the use of props. Ideal for family portraits, more animated action poses, fashion and commercial shoots.

The EzyFrame Vintage Background features the tried and tested aluminium frame and clip on cover design used on our highly successful Skylite panels, Panoramic backgrounds and the newly launched StudioLink Chroma Key solutions. Assembled in a matter of minutes the EzyFrame Vintage background and cover packs down into a small rigid carry case measuring only 103cm x 19cm x 14cm making it extremely portable.

### Features and Benefits

- Aluminium frame
- Highly portable and offers large background coverage
- EzyFrame covers clip easily onto the frame for an impressively taut finish
- Interchangeable with other EzyFrame covers



## EzyFrame Swatches

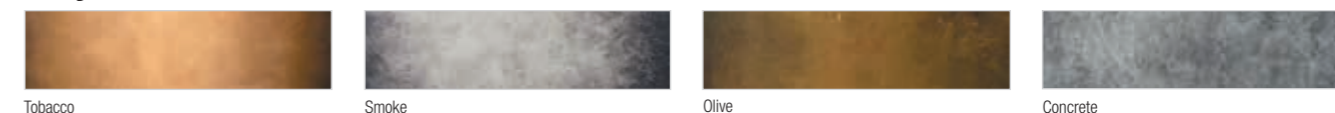

### Specifications

| EzyFrame Backgrounds | Code      |
|----------------------|-----------|
| Tobacco              | LL LB7926 |
| Olive                | LL LB7924 |
| Smoke                | LL LB7928 |
| Concrete             | LL LB7930 |

| EzyFrame Cover | Code      |
|----------------|-----------|
| Tobacco Cover  | LL LB7927 |
| Olive Cover    | LL LB7925 |
| Smoke Cover    | LL LB7929 |
| Concrete Cover | LL LB7931 |

| EzyFrame Accessories           | Code          |
|--------------------------------|---------------|
| Aluminium Frame Support Kit    | LL LA8450     |
| Skylite Rapid Griphead         | LL LA8446     |
| Rigid Case 78cm x 19cm x 14cm  | LL LRCASE775  |
| Rigid Case 103cm x 19cm x 14cm | LL LRCASE1025 |

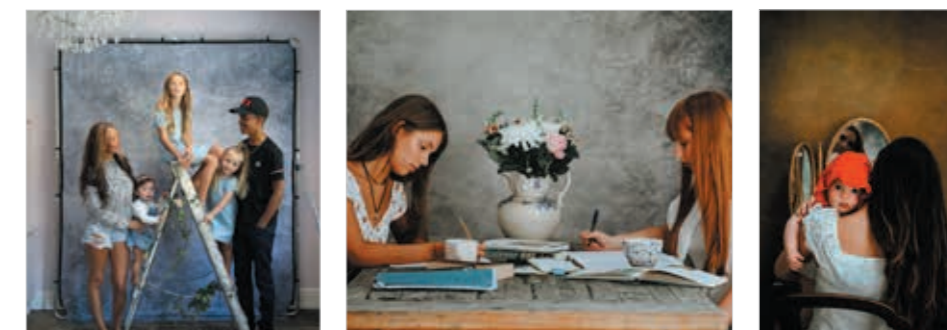

Skylite's special griphead allows it to be fixed to stands and tilted as required. LL LA8446



Aluminium Frame Support Kit LL LA8450



Classic Red Brick



Painted White Brick



Rusty Metal



Derelict Wall



Distressed White Brick



Industrial Grey Brick



Plaster Wall



Wooden Fence

## Urban Collapsible Backgrounds

The urban collapsible backgrounds allow you to create the outdoor look in an instant whether you're in the studio or a client's home. Each double sided background has unique urban feel and can quickly add a new dimension to your portrait sittings. No longer will you have to find locations or be controlled by the weather.

### Features and Benefits

- 4 different surfaces
- Reversible
- Create the location effect anywhere
- Collapsible to a third of its original size



Painted White Brick LL LB5707

### Specifications

| Urban Collapsible Backgrounds               | Size       | Code      |
|---|------------|-----------|
| Classic Red Brick / Distressed White Brick  | 1.5 x 2.1m | LL LB5706 |
| Painted White Brick / Industrial Grey Brick | 1.5 x 2.1m | LL LB5707 |
| Rusty Metal / Plaster Wall                  | 1.5 x 2.1m | LL LB5713 |
| Derelict Wall / Wooden Fence                | 1.5 x 2.1m | LL LB5715 |

Some camera sensors may interpret the colours used on our printed backgrounds differently.



Distressed White Brick LL LB5706



Classic Red Brick LL LB5706



Industrial Grey Brick LL LB5707

## Plain Background Swatches



Black



Purple



Red



Grey



Blue



Pink

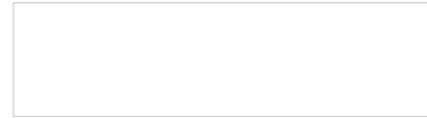

White

## Plain Collapsible Backgrounds

A range of collapsible, reversible, plain coloured backgrounds. In addition to the standard black, white and grey we now have a range of punchy vibrant colours for a more modern look to your portraits.

A simple solution for flat plain coloured backgrounds, a great way to get the seamless paper effect but in a collapsible portable format!

### Features and Benefits

- Crease resistant
- Single colours
- Reversible
- Collapsible
- Ideal for passport, ID and corporate photos



### Specifications

| Plain Collapsible Backgrounds | Size                   | Code      |
|-------------------------------|------------------------|-----------|
| Blue / Pink                   | 1.8m x 2.15m (6' x 7') | LL LB6751 |
| Red / Purple                  | 1.8m x 2.15m (6' x 7') | LL LB6752 |
| Black / White                 | 1.5m x 1.8m (5' x 6')  | LL LC5621 |
| Black / White                 | 1.8m x 2.15m (6' x 7') | LL LB5921 |
| Black / White                 | 1.8m x 2.75m (6' x 9') | LL LB6921 |
| Black / White with train      | 1.8m x 2.15m (6' x 7') | LL LB6701 |
| Black / Mid Grey              | 1.5m x 1.8m (5' x 6')  | LL LB56GB |
| Black / Mid Grey              | 1.8m x 2.15m (6' x 7') | LL LB67GB |
| White / Mid Grey              | 1.5m x 1.8m (5' x 6')  | LL LB56GW |
| White / Mid Grey              | 1.8m x 2.15m (6' x 7') | LL LB67GW |



 **AVENGER**

Avenger prides itself on producing a range of highly respected grip equipment products that continually meet the needs of the most demanding users in the cinema, broadcast, entertainment, video and photographic markets. Designed and manufactured in Italy, the brand was established in 1988 by Manfrotto and is part of the Vitec Group Plc. The Avenger range offers a comprehensive portfolio of products including stands, booms, clamps, couplers, light controls, support arms and accessories.

All products are designed to conform to the strict industry standards of quality, performance and safety. Product quality is at the core of the business.

Using the latest computer-aided CAD/CAM systems and FEM simulators, the world-class research and development facility in Italy delivers fully optimized solutions which are then manufactured to an extremely high level of precision and tolerance, using only the finest materials. Each product is also rigorously tested to ensure optimal performance and the ability to withstand repeated use, extreme working conditions, high stress situations, and heavy payloads. These high levels of quality and performance are key to ensuring that Avenger products meet and exceed internationally recognised safety standards such as TÜV, DIN and CE.

These certifications set Avenger apart from other brands on the market and provide its customers with complete assurance that products surpass the most stringent tests for safety and reliability. As a result, many of Avenger's products have become the standard go-to products and are often asked for by name – such as the Strato Safe, and the Long John Silver. The original and highly respected Super Clamp family, together with the industry standard 244 Friction Arm, are essential pieces of a professional's grip equipment.



## Products:

- Century stands
- Century stands accessories
- Baby stands
- Combo stands
- Roller stands
- Lighting booms system
- Wind Up stands
- Strato Safe stands
- Long John Silver stands
- Pump cup system
- Wall plates
- Light control



# Century stands



A2016D

## DETACHABLE

**A2016D**  
**C-STAND 16 DETACHABLE CHROME FINISH VERSION**

|                |                |                |                |                 |
|----------------|----------------|----------------|----------------|-----------------|
|                |                |                |                |                 |
| 84cm<br>33.1in | 155cm<br>61in  | 84cm<br>33.1in | 95cm<br>37.4in | 5,6kg<br>12.3lb |
|                |                |                |                |                 |
| 10kg<br>22lb   | 28mm<br>1 1/8" | 16mm<br>5/8"   | 28mm<br>1 1/8" |                 |

Chrome plated steel stand.  
3 sections, 2 risers. Ø: 35, 30, 25mm. Leg Ø: 25mm.

**A2016DCB**  
**C-STAND 16 DETACHABLE BLACK CHROME FINISH VERSION**

**A2022D**  
**C-STAND 22 DETACHABLE CHROME FINISH VERSION**

|                 |                 |                 |                |               |
|-----------------|-----------------|-----------------|----------------|---------------|
|                 |                 |                 |                |               |
| 110cm<br>43.3in | 222cm<br>87.4in | 110cm<br>43.3in | 95cm<br>37.4in | 5,9kg<br>13lb |
|                 |                 |                 |                |               |
| 10kg<br>22lb    | 28mm<br>1 1/8"  | 16mm<br>5/8"    | 28mm<br>1 1/8" |               |

Chrome plated steel stand.  
3 sections, 2 risers. Ø: 35, 30, 25mm. Leg Ø: 25mm.

**A2022DCB**  
**C-STAND 22 DETACHABLE BLACK CHROME FINISH VERSION**

**A2030D**  
**C-STAND 30 DETACHABLE CHROME FINISH VERSION**

|                 |                  |                 |                |                 |
|-----------------|------------------|-----------------|----------------|-----------------|
|                 |                  |                 |                |                 |
| 134cm<br>52.8in | 300cm<br>118.1in | 134cm<br>52.8in | 95cm<br>37.4in | 6,2kg<br>13.7lb |
|                 |                  |                 |                |                 |
| 10kg<br>22lb    | 28mm<br>1 1/8"   | 16mm<br>5/8"    | 28mm<br>1 1/8" |                 |

Chrome plated steel stand.  
3 sections, 2 risers. Ø: 35, 30, 25mm. Leg Ø: 25mm.

**A2030DCB**  
**C-STAND 30 DETACHABLE BLACK CHROME FINISH VERSION**



A2018F



A2018L

## STANDARD BASE

**A2018F**  
**C-STAND 18**  
**CHROME FINISH VERSION**

|                |                 |                |                |                |
|----------------|-----------------|----------------|----------------|----------------|
|                |                 |                |                |                |
| 84cm<br>33.1in | 175cm<br>68.9in | 84cm<br>33.1in | 95cm<br>37.4in | 4,3kg<br>9.5lb |
|                |                 |                |                |                |
| 8kg<br>17.6lb  | 16mm<br>5/8"    |                |                |                |

Chrome plated steel stand.  
3 sections, 2 risers.  
Ø: 35, 30, 25mm. Leg Ø: 25mm.

**A2018FJCB**  
**C-STAND 18 BLACK CHROME FINISH**  
**JAPANESE VERSION\***

**A2025F**  
**C-STAND 25**  
**CHROME FINISH VERSION**

|                 |                 |                 |                |             |
|-----------------|-----------------|-----------------|----------------|-------------|
|                 |                 |                 |                |             |
| 110cm<br>43.3in | 253cm<br>99.6in | 110cm<br>43.3in | 95cm<br>37.4in | 5kg<br>11lb |
|                 |                 |                 |                |             |
| 10kg<br>22lb    | 16mm<br>5/8"    |                 |                |             |

Chrome plated steel stand.  
3 sections, 2 risers. Ø: 35, 30, 25mm. Leg Ø: 25mm.

**A2025FCB**  
**C-STAND 25**  
**BLACK CHROME FINISH VERSION**

**A2033F**  
**C-STAND 33**  
**CHROME FINISH VERSION**

|                 |                  |                 |                |                 |
|-----------------|------------------|-----------------|----------------|-----------------|
|                 |                  |                 |                |                 |
| 134cm<br>52.8in | 328cm<br>129.1in | 134cm<br>52.8in | 95cm<br>37.4in | 5,5kg<br>12.1lb |
|                 |                  |                 |                |                 |
| 10kg<br>22lb    | 16mm<br>5/8"     |                 |                |                 |

Chrome plated steel stand.  
3 sections, 2 risers. Ø: 35, 30, 25mm. Leg Ø: 25mm.

**A2018FCB**  
**C-STAND 33**  
**BLACK CHROME FINISH VERSION**

## SLIDING LEG

**A2018L**  
**C-STAND 18 SLIDING LEG CHROME FINISH VERSION**

|                |                 |                |                |                |
|----------------|-----------------|----------------|----------------|----------------|
|                |                 |                |                |                |
| 84cm<br>33.1in | 175cm<br>68.9in | 84cm<br>33.1in | 95cm<br>37.4in | 4,3kg<br>9.5lb |
|                |                 |                |                |                |
| 8kg<br>17.6lb  | 16mm<br>5/8"    |                |                |                |

Chrome plated steel stand.  
3 sections, 2 risers. Ø: 35, 30, 25mm. Leg Ø: 25mm.

**A2018LCB**  
**C-STAND 18 SLIDING LEG BLACK CHROME FINISH VERSION**

**A2018LJ**  
**C-STAND 18 SLIDING LEG CHROME FINISH JAPANESE VERSION\***

**A2018LJCB** **C-STAND 18 SLIDING LEG BLACK CHROME FINISH JAPANESE VERSION\***

**A2025L**  
**C-STAND 25 SLIDING LEG CHROME FINISH VERSION**

|                 |                 |                 |                |                 |
|-----------------|-----------------|-----------------|----------------|-----------------|
|                 |                 |                 |                |                 |
| 110cm<br>43.3in | 253cm<br>99.6in | 110cm<br>43.3in | 95cm<br>37.4in | 5,8kg<br>12.8lb |
|                 |                 |                 |                |                 |
| 10kg<br>22lb    | 16mm<br>5/8"    |                 |                |                 |

Chrome plated steel stand.  
3 sections, 2 risers. Ø: 35, 30, 25mm. Leg Ø: 25mm.

**A2025LCB**  
**C-STAND 25 SLIDING LEG BLACK CHROME FINISH VERSION**

**A2025LJ**  
**C-STAND 25 SLIDING LEG CHROME FINISH JAPANESE VERSION\***

**A2025LJCB** **C-STAND 25 SLIDING LEG BLACK CHROME FINISH JAPANESE VERSION\***

**A2033L**  
**C-STAND 33 SLIDING LEG CHROME FINISH VERSION**

|                 |                  |                 |                |                 |
|-----------------|------------------|-----------------|----------------|-----------------|
|                 |                  |                 |                |                 |
| 134cm<br>52.8in | 328cm<br>129.1in | 134cm<br>52.8in | 95cm<br>37.4in | 5,5kg<br>12.1lb |
|                 |                  |                 |                |                 |
| 10kg<br>22lb    | 16mm<br>5/8"     |                 |                |                 |

Chrome plated steel stand.  
3 sections, 2 risers. Ø: 35, 30, 25mm. Leg Ø: 25mm.

**A2033LCB**  
**C-STAND 33 SLIDING LEG BLACK CHROME FINISH VERSION**

**A2033LJ**  
**C-STAND 33 SLIDING LEG CHROME FINISH JAPANESE VERSION\***

**A2033LJCB** **C-STAND 33 SLIDING LEG BLACK CHROME FINISH JAPANESE VERSION\***

\* Please note: the Japanese versions of the stands have a 17,5mm female top attachment



17,5mm



# Century stands



A2009



A2014

## BASE

**A2009  
C-STAND BASE  
CHROME FINISH VERSION**

|                |                |                |                |
|----------------|----------------|----------------|----------------|
|                |                |                |                |
| 27cm<br>10.6in | 95cm<br>37.4in | 2.7kg<br>6.6lb | 28mm<br>1" 1/8 |

**A2009CB  
C-STAND BASE  
CHROME FINISH VERSION**

**A2007  
C-STAND MINI BASE  
CHROME FINISH VERSION**

|                |                |                |                |
|----------------|----------------|----------------|----------------|
|                |                |                |                |
| 27cm<br>10.6in | 95cm<br>37.4in | 2.7kg<br>6.6lb | 28mm<br>1" 1/8 |

**A2007CB  
C-STAND MINI BASE  
CHROME FINISH VERSION**



## COLUMN

**A2014  
C-STAND COLUMN 14  
CHROME FINISH VERSION**

|                |                 |                |              |                |
|----------------|-----------------|----------------|--------------|----------------|
|                |                 |                |              |                |
| 68cm<br>26.8in | 139cm<br>54.7in | 2.2kg<br>4.9lb | 16mm<br>5/8" | 28mm<br>1" 1/8 |

3 sections (Ø: 35, 30, 25mm) chrome steel column.

**A2014CB  
C-STAND COLUMN 14  
BLACK CHROME FINISH VERSION**

**A2014  
C-STAND COLUMN 14  
CHROME FINISH VERSION**

|                |                 |                |              |                |
|----------------|-----------------|----------------|--------------|----------------|
|                |                 |                |              |                |
| 95cm<br>37.4in | 139cm<br>54.7in | 2.2kg<br>4.9lb | 16mm<br>5/8" | 28mm<br>1" 1/8 |

3 sections (Ø: 35, 30, 25mm) chrome steel column.

**A2020CB  
C-STAND COLUMN 20  
BLACK CHROME FINISH VERSION**

**A2020JCB  
C-STAND COLUMN 20  
BLACK CHROME FINISH JAPANESE  
VERSION\***

**A2029  
C-STAND COLUMN 29  
CHROME FINISH VERSION**

|                 |                  |                |              |                |
|-----------------|------------------|----------------|--------------|----------------|
|                 |                  |                |              |                |
| 118cm<br>46.5in | 285cm<br>112.2in | 3.3kg<br>7.3lb | 16mm<br>5/8" | 28mm<br>1" 1/8 |

3 sections (Ø: 35, 30, 25mm) chrome steel column.

**A2029CB  
C-STAND COLUMN 29  
BLACK CHROME FINISH VERSION**

## KIT

**A2033FKIT  
C-STAND KIT 33  
CHROME FINISH VERSION**

Chrome plated steel stand.  
3 sections, 2 risers. Ø: 35, 30, 25mm. Leg Ø: 25mm.

includes:  
A2033F C-STAND  
D200 2" GRIP HEAD  
D520 40" EXTENSION GRIP ARM

**A2033FCBKIT  
C-STAND KIT 33  
BLACK CHROME FINISH VERSION**

**A2033LKIT  
C-STAND KIT 33 SLIDING LEG  
CHROME FINISH VERSION**

Chrome plated steel stand.  
3 sections, 2 risers. Ø: 35, 30, 25mm. Leg Ø: 25mm.

includes:  
A2033L C-STAND  
D200 2" GRIP HEAD  
D520 40" EXTENSION GRIP ARM

**A2030DKIT  
C-STAND KIT 30 DETACHABLE  
CHROME FINISH VERSION**

Chrome plated steel stand.  
3 sections, 2 risers. Ø: 35, 30, 25mm. Leg Ø: 25mm.

includes:  
A2030D C-STAND  
D200 2" GRIP HEAD  
D520 40" EXTENSION GRIP ARM

**A2030DCBKIT  
C-STAND KIT 30 DETACHABLE  
BLACK CHROME FINISH VERSION**

**AVCSA1301B  
TRIPLE C ROLLER CASE FOR  
DETACHABLE C-STANDS AND  
ACCESSORIES**

|                  |              |                |
|------------------|--------------|----------------|
| Internal size    |              |                |
| height           | Width        | Length         |
| 19cm / 13.8in    | 35cm / 7.5in | 120cm / 47.2in |
| External Size    |              |                |
| height           | Width        | Length         |
| 40cm / 15.7in    | 28cm / 11in  | 128cm / 50.4in |
| Weight           |              |                |
| 7.8kg / 17.2 lbs |              |                |



\* Please note: the Japanese versions of the stands have a 17,5mm female top attachment





# Century stands accessories



**D200  
2 1/2 GRIP HEAD**

**i** 0,55kg  
**U** 16mm  
1.2lb 5/8"

Avenger's most popular grip accessory. The D200 Grip Head has hundreds of functions. Unlike any other Grip Head, the D200 utilizes a series of washers for extra locking torque and the use of automotive-quality brake pad discs for secure, non-slip security. Connect with E600 snap-in pin or E600C snap-in pin to attach to the original Super Clamp.

**D200B  
2 1/2 GRIP HEAD  
BLACK FINISH VERSION**



**D250  
GAG GOBO GRIP HEAD**

**i** 0,46kg  
**i** 16mm  
1lb 5/8"

This unique double Grip Head system provides the flexibility of a second grip head allowing hundreds of uses including doubling up scrims and flags.



**D210J  
SNAP-IN GRIP HEAD  
JAPANESE VERSION**

**i** 0,75kg  
**U** 17,5mm  
1.7lb

Combining the multi-functional D200 Grip Head with a 17,5mm pin to interface with the Japanese attachment. The D210J allows you to hang flags and scrims in positions that light stands can't reach.

**D210JB  
SNAP-IN GRIP HEAD  
BLACK JAPANESE  
VERSION**



**D240  
GRIP HEAD  
WITH SWIVEL PIN**

**i** 1,25kg  
**i** 16mm  
**U** 16mm  
**i** 28mm  
2.8lb 5/8" 5/8" 1" 1/8"

Two famous accessories connected together to assure a wide range of fixing solutions. Attachments: 16mm male pin + 16mm female socket 28mm male pin.



**D230  
SUPER CLAMP  
GRIP HEAD**

**i** 0,95kg  
2.1lb

This kit includes the D200B Grip Head and the Avenger C1575B Super Clamp.



**D100  
DOUBLE GRIP HEAD**

**i** 0,87kg  
1.9lb

A combination of two sets of Grip Head discs mounted on a steel plate with a 10mm rod with a length of 13,5cm (5.3").



**D220  
GRIP HELPER**

**i** 1,1kg  
**i** 16mm  
2.4lb 5/8"

Just as the name suggests, the Grip Helper is like three Grip Heads in one. Two independent grip heads sandwich a third with a fixed 16mm pin. This system allows multiple light control accessories to mount in front of fixtures without the need for numerous light stands.



**D500  
20" EXTENSION  
GRIP ARM**

**i** 1,03kg  
2.3lb

Normally used in combination with a Grip Head (art. D200) it provides an extended grip point for scrims and flags. Pipe length 51cm (20").

**D500B  
20" EXTENSION  
GRIP ARM  
BLACK FINISH VERSION**



**D520  
40" EXTENSION  
GRIP ARM**

**i** 1,28kg  
2.8lb

Normally used in combination with a Grip Head (art. D200) it provides an extended grip point for scrims and flags or small lights. Pipe length 102cm (40").

**D520B  
40" EXTENSION  
GRIP ARM  
BLACK FINISH VERSION**



**D530L  
40" EXTENSION ARM  
AND GRIP HEAD (D200)**

**i** 2,15kg  
4.7lb

Normally used in combination with a Grip Head (art. D200) it provides an extended grip point for scrims and flags or small lights. Pipe length 102cm (40"). It includes D200 Grip Head.

**D530L  
40" EXTENSION ARM  
AND GRIP HEAD (D200B)  
BLACK FINISH VERSION**



**D800KIT  
GRIP KIT**

Set of accessories that work on their own or in combination with stands to support scrims, flags and lighting fixtures to provide precision and secure control. Kit comprises of: D200B Black Grip Head. E600 Snap-in 16mm pin. D520B Black 40" Extension Arm. C1575B Black Super Clamp. H4BAG Grip Kit Bag.



**D420  
JUMBO GAG GOBO**

**i** 1,3kg  
2.9lb

This double 10mm (4" 1/2) Grip Head allows for multiple overheads to be used simultaneously.

**D420B  
JUMBO GAG GOBO  
BLACK FINISH VERSION**



**D400  
4 1/2" JUMBO GRIP HEAD**

**i** 2,35kg  
5.2lb  
**i** 28mm  
**U** 28mm  
1" 1/8" 1" 1/8"

Designed to convert a Junior Stand into an Overhead Stand, the D400 incorporates a 10mm (4" 1/2) Grip Head with a Junior Stud and receiver.

**D400B  
4 1/2" JUMBO GRIPHEAD  
BLACK FINISH VERSION**



**E600  
SNAP-IN PIN**

**i** 16mm  
5/8"

Specifically designed to connect Grip Head to Super Clamp. Aluminum made.

**E600C  
SNAP-IN PIN  
STEEL VERSION**



**D050  
SET OF 6 BLUE T-TOPS**

Rubber cover gives better grip for 80mm T-handles, even in cold weather.





# Baby stands



A0010



A0017

## STEEL BASE AND ALU COLUMN

### A0010 BABY STAND 10

|                |                 |                |                |                |
|----------------|-----------------|----------------|----------------|----------------|
|                |                 |                |                |                |
| 52cm<br>20.5in | 100cm<br>39.4in | 47cm<br>18.5in | 43cm<br>16.9in | 2.5kg<br>5.5lb |
|                |                 |                |                |                |
| 15kg<br>33.1lb | 16mm<br>5/8"    |                |                |                |

Steel legs and aluminum risers, silver only.  
3 sections, 2 risers. Ø: 35, 30, 25 mm.  
Leg: 20x20mm. 1 levelling leg.

### A0010J BABY STAND 10 JAPANESE VERSION\*

### A0017 BABY STAND 17

|                |                 |                |                |                |
|----------------|-----------------|----------------|----------------|----------------|
|                |                 |                |                |                |
| 82cm<br>32.3in | 175cm<br>68.9in | 73cm<br>28.7in | 75cm<br>29.5in | 3.4kg<br>7.7lb |
|                |                 |                |                |                |
| 4kg<br>8.8lb   | 16mm<br>5/8"    |                |                |                |

Steel legs and aluminum risers, silver only.  
3 sections, 2 risers. Ø: 35, 30, 25 mm.  
Leg: 20x20mm. 1 levelling leg.

## ALUMINIUM

### A0025B ALU BABY STAND 25

|                |                 |                |                |
|----------------|-----------------|----------------|----------------|
|                |                 |                |                |
| 98cm<br>38.6in | 250cm<br>98.4in | 87cm<br>34.3in | 87cm<br>34.3in |
|                |                 |                |                |
| 3kg<br>6.6lb   | 4kg<br>8.8lb    | 16mm<br>5/8"   |                |

Black aluminum stand.  
3 sections, 2 risers. Ø: 35, 30, 25, 20mm.  
Leg: 20x20mm. 1 levelling leg.

### A0030B ALU BABY STAND 30

|                 |                  |                 |                 |
|-----------------|------------------|-----------------|-----------------|
|                 |                  |                 |                 |
| 113cm<br>44.5in | 300cm<br>118.1in | 100cm<br>39.4in | 100cm<br>39.4in |
|                 |                  |                 |                 |
| 3.5kg<br>7.7lb  | 10kg<br>22lb     | 16mm<br>5/8"    |                 |

Black aluminum stand.  
4 sections, 3 risers. Ø: 35, 30, 25, 20mm.  
Leg: 20x20mm. 1 levelling leg.

### A0035B ALU BABY STAND 35

|                 |                  |                 |                 |
|-----------------|------------------|-----------------|-----------------|
|                 |                  |                 |                 |
| 126cm<br>49.6in | 350cm<br>137.8in | 112cm<br>44.1in | 100cm<br>39.4in |
|                 |                  |                 |                 |
| 3.5kg<br>7.7lb  | 9kg<br>19.8lb    | 16mm<br>5/8"    |                 |

Black aluminum stand.  
4 sections, 3 risers. Ø: 35, 30, 25, 20mm.  
Leg: 20x20mm. 1 levelling leg.

### A0040B ALU BABY STAND 40

|                 |                  |                 |                 |
|-----------------|------------------|-----------------|-----------------|
|                 |                  |                 |                 |
| 142cm<br>55.9in | 400cm<br>157.5in | 124cm<br>48.8in | 114cm<br>44.9in |
|                 |                  |                 |                 |
| 4kg<br>8.8lb    | 9kg<br>19.8lb    | 16mm<br>5/8"    |                 |

Black aluminum stand.  
4 sections, 3 risers. Ø: 35, 30, 25, 20mm.  
Leg: 20x20mm. 1 levelling leg.

### A0045B ALU BABY STAND 45

|                 |                  |                 |                 |
|-----------------|------------------|-----------------|-----------------|
|                 |                  |                 |                 |
| 154cm<br>60.6in | 450cm<br>177.2in | 136cm<br>53.5in | 114cm<br>44.9in |
|                 |                  |                 |                 |
| 4.1kg<br>9lb    | 10kg<br>22lb     | 16mm<br>5/8"    |                 |

Black aluminum stand.  
4 sections, 3 risers. Ø: 35, 30, 25, 20mm.  
Leg: 20x20mm. 1 levelling leg.

## STEEL

### A0030CS ALU BABY STAND 30

|                 |                  |                 |                 |
|-----------------|------------------|-----------------|-----------------|
|                 |                  |                 |                 |
| 113cm<br>44.5in | 300cm<br>118.1in | 100cm<br>39.4in | 100cm<br>39.4in |
|                 |                  |                 |                 |
| 6kg<br>13.2lb   | 10kg<br>22lb     | 16mm<br>5/8"    |                 |

Chrome plated steel stand.  
4 sections, 3 risers. Ø: 35, 30, 25, 20mm.  
Leg: 20x20mm. 1 levelling leg.

### A0035CS STEEL BABY STAND 35

|                 |                  |                 |                 |
|-----------------|------------------|-----------------|-----------------|
|                 |                  |                 |                 |
| 126cm<br>49.6in | 350cm<br>137.8in | 112cm<br>44.1in | 100cm<br>39.4in |
|                 |                  |                 |                 |
| 7kg<br>15.4lb   | 9kg<br>19.8lb    | 16mm<br>5/8"    |                 |

Chrome plated steel stand.  
4 sections, 3 risers. Ø: 35, 30, 25, 20mm.  
Leg: 20x20mm. 1 levelling leg.

### A0040CS STEEL BABY STAND 40

|                 |                  |                 |                 |
|-----------------|------------------|-----------------|-----------------|
|                 |                  |                 |                 |
| 142cm<br>55.9in | 400cm<br>157.5in | 124cm<br>48.8in | 114cm<br>44.9in |
|                 |                  |                 |                 |
| 7.8kg<br>17.2lb | 9kg<br>19.8lb    | 16mm<br>5/8"    |                 |

Chrome plated steel stand.  
4 sections, 3 risers. Ø: 35, 30, 25, 20mm.  
Leg: 20x20mm. 1 levelling leg.

### A0045CS STEEL BABY STAND 45

|                 |                  |                 |                 |
|-----------------|------------------|-----------------|-----------------|
|                 |                  |                 |                 |
| 154cm<br>60.6in | 450cm<br>177.2in | 136cm<br>53.5in | 114cm<br>44.9in |
|                 |                  |                 |                 |
| 8.1kg<br>17.9lb | 9kg<br>19.8lb    | 16mm<br>5/8"    |                 |

Chrome plated steel stand.  
4 sections, 3 risers. Ø: 35, 30, 25, 20mm.  
Leg: 20x20mm. 1 levelling leg.



A0040B



A0040CS

\* Please note: the Japanese versions of the stands have a 17,5mm female top attachment





# Combo Stands



A1045CS

A1045B

## ALUMINIUM

### A1020B ALU COMBO STAND 20

|                 |                 |                |                |                 |
|-----------------|-----------------|----------------|----------------|-----------------|
|                 |                 |                |                |                 |
| 110cm<br>43.3in | 198cm<br>78in   | 93cm<br>36.6in | 80cm<br>31.5in | 4,9kg<br>10.8lb |
|                 |                 |                |                |                 |
| 25kg<br>55.1lb  | 28mm<br>1" 1/8" | 16mm<br>5/8"   | A9000NB        |                 |

Aluminum legs with aluminum risers.  
3 sections, 2 risers. Ø: 45, 40, 35mm.  
Leg: 25x25mm. 1 levelling leg.

### A1035B ALU COMBO STAND 35

|                 |                  |                 |                 |               |
|-----------------|------------------|-----------------|-----------------|---------------|
|                 |                  |                 |                 |               |
| 168cm<br>66.1in | 350cm<br>137.8in | 142cm<br>55.9in | 134cm<br>52.8in | 7kg<br>15.4lb |
|                 |                  |                 |                 |               |
| 30kg<br>66.1lb  | 28mm<br>1" 1/8"  | 16mm<br>5/8"    | A9000NB         |               |

Aluminum stand.  
3 sections, 2 risers. Ø: 45, 40, 35mm.  
Leg: 25x25mm. 1 levelling leg.

### A1045B ALU COMBO STAND 45

|                 |                  |               |                 |               |
|-----------------|------------------|---------------|-----------------|---------------|
|                 |                  |               |                 |               |
| 179cm<br>70.5in | 450cm<br>177.2in | 155cm<br>61in | 134cm<br>52.8in | 7kg<br>15.4lb |
|                 |                  |               |                 |               |
| 30kg<br>66.1lb  | 28mm<br>1" 1/8"  | 16mm<br>5/8"  | A9000NB         |               |

Aluminum stand.  
4 sections, 3 risers. Ø: 45, 40, 35, 30mm.  
Leg: 25x25mm. 1 levelling leg.

## STEEL

### A1010CS STEEL COMBO STAND 10

|                |                 |                |                |                |
|----------------|-----------------|----------------|----------------|----------------|
|                |                 |                |                |                |
| 64cm<br>25.2in | 100cm<br>39.4in | 62cm<br>24.4in | 57cm<br>22.4in | 4,5kg<br>9.9lb |
|                |                 |                |                |                |
| 30kg<br>66.1lb | 28mm<br>1" 1/8" | 16mm<br>5/8"   | A9000NB        |                |

Chrome steel stand.  
2 sections, 1 riser. Ø: 35, 30mm.  
Leg: 20x20mm. 1 levelling leg.

### A1020CS STEEL COMBO STAND 20

|                 |                 |                |                |                 |
|-----------------|-----------------|----------------|----------------|-----------------|
|                 |                 |                |                |                 |
| 110cm<br>43.3in | 198cm<br>78in   | 93cm<br>36.6in | 80cm<br>31.5in | 7,2kg<br>15.9lb |
|                 |                 |                |                |                 |
| 35kg<br>77.2lb  | 28mm<br>1" 1/8" | 16mm<br>5/8"   | A9000NB        |                 |

Chrome steel stand.  
3 sections, 2 risers. Ø: 45, 40, 35mm.  
Leg: 25x25mm. 1 levelling leg.

### A1035CS STEEL COMBO STAND 35

|                 |                  |                 |                 |                |
|-----------------|------------------|-----------------|-----------------|----------------|
|                 |                  |                 |                 |                |
| 168cm<br>66.1in | 350cm<br>137.8in | 142cm<br>55.9in | 134cm<br>52.8in | 12kg<br>26.5lb |
|                 |                  |                 |                 |                |
| 40kg<br>88.2lb  | 28mm<br>1" 1/8"  | 16mm<br>5/8"    | A9000NB         |                |

Chrome steel stand.  
3 sections, 2 risers. Ø: 45, 40, 35mm.  
Leg: 25x25mm. 1 levelling leg.

### A1045CS STEEL COMBO STAND 45

|                 |                  |               |                 |                |
|-----------------|------------------|---------------|-----------------|----------------|
|                 |                  |               |                 |                |
| 179cm<br>70.5in | 450cm<br>177.2in | 155cm<br>61in | 134cm<br>52.8in | 13kg<br>28.7lb |
|                 |                  |               |                 |                |
| 40kg<br>88.2lb  | 28mm<br>1" 1/8"  | 16mm<br>5/8"  | A9000NB         |                |

Chrome steel stand.  
4 sections, 3 risers. Ø: 45, 40, 35, 30mm.  
Leg: 25x25mm. 1 levelling leg.

Products below are available as optional

### A9000N BRAKED WHEELS

|                |                 |
|----------------|-----------------|
|                |                 |
| 3,3kg<br>7.3lb | 90kg<br>198.4lb |

Ø: 100mm for 20x20 and 25x25mm.  
Square legs. Set of three.



### A9000NB BRAKED WHEELS

Black Finish Version

### D400 4" 1/2 JUMBO GRIPHEAD

|                 |                 |                 |
|-----------------|-----------------|-----------------|
|                 |                 |                 |
| 2,35kg<br>5.2lb | 28mm<br>1" 1/8" | 28mm<br>1" 1/8" |

Designed to convert a Junior Stand into an Overhead Stand, the D400 incorporates a 4" 1/2 (10mm) Grip Head with a Junior Stud and receiver.



### D400B 4" 1/2 JUMBO GRIP HEAD

Black Finish version



# Roller Stands



A5017

A5012

### A5017 ROLLER STAND 17 FOLDING BASE

|                 |                 |                |                |                 |                |              |  |
|-----------------|-----------------|----------------|----------------|-----------------|----------------|--------------|--|
|                 |                 |                |                |                 |                |              |  |
| 108cm<br>42.5in | 170cm<br>66.9in | 98cm<br>38.6in | 75cm<br>29.5in | 5,5kg<br>12.1lb | 12kg<br>26.5lb | 16mm<br>5/8" |  |

Legs and column in steel, risers in aluminum, complete with wheels.  
3 sections, 2 risers. Ø: 35, 30, 25mm.  
Leg: 20x20mm.

### A5012 ROLLER STAND 12 FOLDING BASE

|                |                 |                |                |               |                |                 |              |
|----------------|-----------------|----------------|----------------|---------------|----------------|-----------------|--------------|
|                |                 |                |                |               |                |                 |              |
| 78cm<br>30.7in | 120cm<br>47.2in | 68cm<br>26.8in | 75cm<br>29.5in | 8kg<br>17.6lb | 25kg<br>55.1lb | 28mm<br>1" 1/8" | 16mm<br>5/8" |

Legs and column in steel, risers in aluminum, complete with wheels.  
3 sections, 2 risers. Ø: 45, 40, 35mm.  
Leg: 20x40mm.

### A5033 ROLLER STAND 33 FOLDING BASE

|                 |                  |                 |                |                 |                |              |  |
|-----------------|------------------|-----------------|----------------|-----------------|----------------|--------------|--|
|                 |                  |                 |                |                 |                |              |  |
| 115cm<br>45.3in | 330cm<br>129.9in | 105cm<br>41.3in | 75cm<br>29.5in | 6,3kg<br>13.9lb | 12kg<br>26.5lb | 16mm<br>5/8" |  |

Legs and column in steel, risers in aluminum, complete with wheels.  
4 sections, 3 risers. Ø: 35, 30, 25, 20mm.  
Leg: 20x40mm.

### A5034 ROLLER STAND 34 FOLDING BASE

|                 |                  |               |                |                  |                |                 |              |
|-----------------|------------------|---------------|----------------|------------------|----------------|-----------------|--------------|
|                 |                  |               |                |                  |                |                 |              |
| 142cm<br>55.9in | 340cm<br>133.9in | 132cm<br>52in | 75cm<br>29.5in | 10,7kg<br>23.6lb | 20kg<br>44.1lb | 28mm<br>1" 1/8" | 16mm<br>5/8" |

Legs and column in steel, risers in aluminum, complete with wheels.  
4 sections, 3 risers. Ø: 45, 40, 35, 30mm.  
Leg: 20x40mm.



# Lighting Booms System



D570  
**EXTENSION ARM WITH SWIVEL PIN**

1,1kg 16mm  
2.4lb 5/8"  
Arm length: 91cm (33.8").  
16mm (5/8") female stand attachment.

D570B  
**EXTENSION ARM WITH SWIVEL PIN**

BLACK FINISH VERSION



D600  
**MINI BOOM**

3,6kg 16mm  
7.9lb 5/8"  
Min extension 117cm (46.6").  
Max load 30kg (66.1lb).  
Max extension 212cm (83.5").  
Max load 7kg (15.4lb).  
16mm (5/8") female stand attachment.

D600CB

**MINI BOOM**

BLACK CHROME FINISH VERSION



D650  
**JUNIOR BOOM ARM**

14,8kg 28mm 16mm  
32.6lb 1" 1/8 5/8"  
Min extension 163cm (64.2").  
Max load 40kg (88.2lb).  
Max extension 300cm (118.1").  
Max load 10kg (22lb).  
28mm (1" 1/8) male stand attachment.

PRODUCTS BELOW ARE AVAILABLE AS OPTIONAL



172  
**MINI COUNTERWEIGHT**

1,3kg  
2.9lb



023  
**L-PESO**

4,3kg  
9.5lb

022  
**G-PESO**

6,7kg  
14.8lb



# Wind Up Stands



B6039CS  
**WIND UP STAND 39**

|                 |                  |                 |                 |                |
|-----------------|------------------|-----------------|-----------------|----------------|
| 181cm<br>71.3in | 370cm<br>145.7in | 201cm<br>79.1in | 142cm<br>55.9in | 24kg<br>52.9lb |
| 30kg<br>66.1lb  | 28mm<br>1" 1/8   | 16mm<br>5/8"    |                 |                |

Chrome steel stand.  
3 sections, 2 risers. Ø: 55, 45, 38mm.  
Leg Ø: 30mm.  
1 levelling leg.



B6040X  
**STAINLESS STEEL SUPER WIND UP 40 STAND**

|                 |                |                 |                 |              |
|-----------------|----------------|-----------------|-----------------|--------------|
| 172cm<br>67.7in | 386cm<br>152in | 196cm<br>77.2in | 180cm<br>70.9in | 39kg<br>86lb |
| 80kg<br>176.4lb | 28mm<br>1" 1/8 |                 |                 |              |

Heavy lift stand with strengthened stainless steel column and legs, chrome steel risers and geared column.  
3 sections Ø: 70, 60, 50mm. 2 risers which extended simultaneously at 4,4cm (1.7") per handle turn.  
Safety cable ensures simultaneous retrieval of all sections. Rapid adjustment. Leg Ø 35mm. 1 levelling leg.  
Features braked wheels 474.



# Strato Safe stands



**B7018 STRATO SAFE STAND 18**

|        |        |        |        |        |         |
|--------|--------|--------|--------|--------|---------|
|        |        |        |        |        |         |
| 105cm  | 175cm  | 126cm  | 120cm  | 27kg   | 100kg   |
| 41.3in | 68.9in | 49.6in | 47.2in | 59.5lb | 220.5lb |
|        |        |        |        |        | 28mm    |
|        |        |        |        |        | 1" 1/8  |

Aluminum legs with chrome steel column.  
Features braked wheels  
2 sections, 1 riser. Ø: 70, 60mm.  
Leg: 35x35mm.



**B150-1 STRATO SAFE CRANK-UP**

|        |         |        |        |         |         |
|--------|---------|--------|--------|---------|---------|
|        |         |        |        |         |         |
| 190cm  | 610cm   | 225cm  | 213cm  | 76kg    | 70kg    |
| 74.8in | 240.2in | 88.6in | 83.9in | 167.6lb | 154.3lb |
|        |         |        |        |         | 28mm    |
|        |         |        |        |         | 1" 1/8  |

Aluminum legs with chrome steel column.  
Features braked wheels  
5 sections, 4 riser. Ø: 90, 80, 70, 60, 50mm.  
Leg: 35x35mm.

**B150P-1 STRATO SAFE CRANK-UP WITH PNEUMATIC WHEELS**

|        |         |        |         |         |         |
|--------|---------|--------|---------|---------|---------|
|        |         |        |         |         |         |
| 201cm  | 621cm   | 236cm  | 231cm   | 93,4kg  | 70kg    |
| 79.1in | 244.5in | 92.9in | 83.19in | 205.9lb | 154.3lb |
|        |         |        |         |         | 28mm    |
|        |         |        |         |         | 1" 1/8  |

Aluminum legs with chrome steel column.  
Features braked wheels  
5 sections, 4 riser. Ø: 90, 80, 70, 60, 50mm.  
Leg: 35x35mm.



B7043CS

**B7043CS-1 STRATO SAFE STAND 43**

|       |         |        |        |         |         |
|-------|---------|--------|--------|---------|---------|
|       |         |        |        |         |         |
| 155cm | 427cm   | 185cm  | 182cm  | 60kg    | 70kg    |
| 61in  | 168.1in | 72.8in | 71.7in | 132.3lb | 154.3lb |
|       |         |        |        |         | 28mm    |
|       |         |        |        |         | 1" 1/8  |

Chrome steel stand.  
Features braked wheels  
4 sections, 3 risers. Ø: 90, 80, 70, 60mm.  
Leg: 35x35mm.

**B7047CS-1 STRATO SAFE STAND 47**

|        |         |        |        |         |         |
|--------|---------|--------|--------|---------|---------|
|        |         |        |        |         |         |
| 172cm  | 467cm   | 209cm  | 213cm  | 62kg    | 70kg    |
| 67.7in | 183.9in | 82.3in | 83.9in | 136.7lb | 154.3lb |
|        |         |        |        |         | 28mm    |
|        |         |        |        |         | 1" 1/8  |

Chrome steel stand complet. Features braked wheels.  
4 sections, 2 risers. Ø: 90, 80, 70mm.  
Leg: 35x35mm.  
Included Wind Brace Kit B9000W.

**B9000P PNEUMATIC WHEEL SET FOR STRATO SAFE**

Set of 3 braked pneumatic wheels.

**B900 HARD WHEEL SET FOR STRATO SAFE**

|      |         |
|------|---------|
|      |         |
| 10kg | 70kg    |
| 22lb | 154.3lb |

Set of 3 braked wheels.

**B70XXFFW FOAM FILL WHEEL SET FOR STRATO SAFE**

Set of 3 foam fill wheels..





# Long John Silver stands



**B7057FF**  
**LONG JOHN SILVER STAND WITH FOAM FILL WHEELS**

|                 |                  |                 |                 |                 |                  |
|-----------------|------------------|-----------------|-----------------|-----------------|------------------|
|                 |                  |                 |                 |                 |                  |
| 177cm<br>69.7in | 570cm<br>224.4in | 224cm<br>88.2in | 240cm<br>94.5in | 85kg<br>187.4lb | 120kg<br>264.6lb |
|                 |                  |                 |                 |                 | 28mm<br>1" 1/8   |

Heavy duty stand complete with foam fill braked wheels. 5 sections, 4 risers. Includes Wind Brace Kit.



**B7034FF**  
**LONG JOHN SILVER JUNIOR STAND WITH FOAM FILL WHEELS**

|               |                  |               |               |                 |
|---------------|------------------|---------------|---------------|-----------------|
|               |                  |               |               |                 |
| 127cm<br>50in | 340cm<br>133.9in | 155cm<br>61in | 155cm<br>61in | 70kg<br>154.3lb |

Heavy duty stand. 4 sections, 3 risers.



**C155**  
**SAFETY CABLE**  
Diameter 4mm. Length 100cm.

**C155-01**  
**SAFETY CABLE**  
Diameter 3.5mm. Length 70cm.

**C155-02**  
**SAFETY CABLE**  
Diameter 5mm. Length 70cm.





# Pump Cup System



**F1000**  
PUMP CUP WITH 16MM BABY SWIVEL SPIGOT

|                |              |              |
|----------------|--------------|--------------|
|                |              |              |
| 1,1kg<br>2,4lb | 2kg<br>4,4lb | 16mm<br>5/8" |

Ideal for mounting small lights and camera systems onto flat, non-porous surfaces such as glass. A perfect tool for rigging car shoots.



**F1100**  
PUMP CUP WITH 16MM BABY FIXED SPIGOT

|                |              |              |
|----------------|--------------|--------------|
|                |              |              |
| 0,7kg<br>1,5lb | 2kg<br>4,4lb | 16mm<br>5/8" |

Like the F1000, but with a fixed baby pin for added stability.



**241S**  
PUMP CUP WITH 16MM SOCKET

|                |              |              |
|----------------|--------------|--------------|
|                |              |              |
| 1,2kg<br>2,6lb | 2kg<br>4,4lb | 16mm<br>5/8" |

A suction cup with a fixed 16mm socket incorporating a safety pin for added security.



**241**  
PUMP CUP WITH 16MM SWIVEL SOCKET

|                |              |              |
|----------------|--------------|--------------|
|                |              |              |
| 1,2kg<br>2,6lb | 2kg<br>4,4lb | 16mm<br>5/8" |

Suction cup for small fixtures and lightweight equipment. Diameter: 150mm. 16mm bushing with safety pin.



# Wall Plates



**F301**  
BABY WALL PLATE

|                |              |
|----------------|--------------|
|                |              |
| 0,4kg<br>0,9lb | 16mm<br>5/8" |

Baby plates allow for the quick mounting of fixtures in places where light stands and clamps cannot be used.



**F300**  
JUNIOR WALL PLATE

|                 |                 |
|-----------------|-----------------|
|                 |                 |
| 0,68kg<br>1,5lb | 28mm<br>1" 1/8" |

A wall plate with a junior receiver to mount larger fixtures.



**F810**  
BABY PLATE WITH 16MM SWIVEL SPIGOT

|                |              |
|----------------|--------------|
|                |              |
| 0,8kg<br>1,8lb | 16mm<br>5/8" |

Unique to the Avenger line, this baby plate allows fixtures to be fine-tuned with the built-in swiveling baby pin.



**F800**  
3" BABY WALL PLATE

|                |              |
|----------------|--------------|
|                |              |
| 0,4kg<br>0,9lb | 16mm<br>5/8" |

Baby plates allow for the quick mounting of fixtures in places where light stands and clamps cannot be used. Length 3".



**F805**  
6" BABY WALL PLATE

|                 |              |
|-----------------|--------------|
|                 |              |
| 0,72kg<br>1,6lb | 16mm<br>5/8" |

Baby plates allow for the quick mounting of fixtures in places where light stands and clamps cannot be used. Length 6".



**F808**  
9" BABY WALL PLATE

|                 |              |
|-----------------|--------------|
|                 |              |
| 0,85kg<br>1,9lb | 16mm<br>5/8" |

Baby plates allow for the quick mounting of fixtures in places where light stands and clamps cannot be used. Length 9".



**F809**  
BABY PLATE WITH 90° PIN

|                 |              |
|-----------------|--------------|
|                 |              |
| 0,65kg<br>1,4lb | 16mm<br>5/8" |

When a light stand or a clamp cannot be used to support fixtures, this baby plate with a right angle can be mounted on the wall.



# Light control

## BUTTERFLY TEXTILES

| Fabric                           | Size [cm]<br>Size (feet) | 120x120<br>4x4 | 240x240<br>8x8 | 360x360<br>12x12 | 600x600<br>20x20 |
|----------------------------------|--------------------------|----------------|----------------|------------------|------------------|
| Black Commando                   | -                        | -              | -              | -                | I 930BL*         |
| Black Single Net                 | -                        | -              | -              | I 920BSN         | I 930BSN         |
| Black Double Net                 | -                        | -              | -              | I 920BDN         | I 930BDN         |
| Silk (artificial)                | -                        | I 915K*        | I 920K*        | I 930K*          | -                |
| Silk 1/4 Stop                    | -                        | -              | I 920K4*       | -                | -                |
| Soft Diffuser (Grid)             | I 905SD                  | -              | I 920SD*       | I 930SD*         | -                |
| Soft Diffuser Light (Light Grid) | -                        | I 915SDL*      | I 920SDL*      | I 930SDL*        | -                |
| Silver / White                   | -                        | I 915SW*       | I 920SW*       | -                | -                |
| White / Gold                     | -                        | -              | -              | I 930WG*         | -                |
| Sunfire / Silver                 | -                        | I 915SUS*      | -              | -                | -                |
| CromaKey Green                   | -                        | -              | I 920CKG*      | I 930CKG*        | -                |

\* Textile obtained by sewing two or more pieces of fabric together.



## SCRIMS AND FLAGS

Made of steel spring tube combined with unique fabrics, Scrims and Flags are light and strong and cut or soften light with great effects. To achieve the ideal positioning performance of Scrims and Flags, Avenger provides a complete Grip Head system. All textiles are also sold separately as spares in case your originals become damaged.

| Fabric                  | Size (Inches)<br>Size [cm] | 12x18<br>30x45 | 18x24<br>45 x 60 | 24x30<br>60x75 | 24x36<br>60x90 | 30x36<br>75x90 | 48x48<br>120x120 |
|-------------------------|----------------------------|----------------|------------------|----------------|----------------|----------------|------------------|
| Solid Black Flag        |                            | I 600B         | I 650B           | I 700B         | I 750B         | I 780B         | I 1024           |
| Black Single Scrim      |                            | -              | I 650S           | -              | I 750S         | -              | I 790S           |
| Black Double Scrim      |                            | -              | I 650D           | -              | I 750D         | -              | I 790D           |
| Black Triple Scrim      |                            | -              | -                | -              | I 750T         | -              | -                |
| White Single Scrim      |                            | -              | -                | -              | -              | -              | I 790SW          |
| White Triple Scrim      |                            | -              | -                | -              | -              | -              | I 790TW          |
| Silk (artificial) Scrim |                            | -              | -                | -              | I 750K         | -              | I 790K           |



## FLOPPIES AND CUTTERS

| Fabric        | Code   | Size [inches] | Size [cm] |
|---------------|--------|---------------|-----------|
| Meat Axe Flag | I 1010 | 30x36         | 75x90     |
| Cutter        | I 1020 | 10x42         | 25x106    |
| Cutter        | I 1021 | 18x18         | 46x120    |
| Floppy Cutter | I 1030 | 24x72         | 60x182    |
| Floppy Cutter | I 1031 | 48x48         | 120x120   |

To order spare part covers for floppies and cutters add the letter "R" in front of the order code. I.e. RI1021, is the spare part cover for the item I1021 CUTTER 18x48".



All our flags, floppies and cutters are made using a strong webbing all around the frame, to protect the edges from wear.

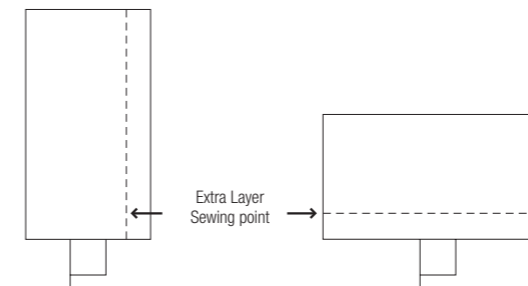

Floppies are Cutters made with an additional piece of fabric, which is fixed with velcro and can be unfolded, becoming twice its original size. See drawing to understand where the extra layer is sewed on the frame.

## D.I.Y. BUTTERFLY PIPE CORNER KIT

Pipe specifications for use with the D.I.Y Butterfly Pipe Corner Kit.

| Code  | Nominal Bore [inches] | Outside Diameter [inches] | Nominal Bore [mm] | Outside Diameter [mm] |
|-------|-----------------------|---------------------------|-------------------|-----------------------|
| H9000 | 1 1/2"                | 1 29/32"                  | 38                | 48.3                  |

This kit give you the possibility of making frames of any dimension, using standard aluminum pipes.



Pipe connection.





## FOLD AWAY FRAME

| Code  | Frame Size [feet] | Frame Size [cm] | Tube Thickness [mm] | Frame Support | Transport Dimension [mm] | Weight [kg] |
|-------|-------------------|-----------------|---------------------|---------------|--------------------------|-------------|
| H2006 | 6x6               | 183x183         | 2                   | Ear Type 2    | 1915x150x30              | 6,6         |
| H2008 | 8x8               | 244x244         | 2                   | Ear Type 2    | 2525x150x30              | 11,3        |
| H2010 | 12x8              | 366x244         | 2                   | Ear Type 2    | 3740x150x30              | 14,4        |
| H2012 | 12x12             | 366x366         | 2                   | Ear Type 2    | 3740x150x30              | 17,6        |



**FOLD-OUT AND SET UP**  
Just fix the frame holder and it is ready to mount! To order Ear support alone use code RH02015.

**FOLD-DOWN AND BRING UP**  
Need to move the frame quickly from set to set? No problem, just remove the frame holder, fold down the frame and carry the frame with the textile still fitted!



Fabric and stands are not included

## FOLD AWAY FRAME COMPACT

| Code  | Frame Size [feet] | Frame Size [cm] | Tube Thickness [mm] | Frame Support | Transport Dimension [mm] | Weight [kg] |
|-------|-------------------|-----------------|---------------------|---------------|--------------------------|-------------|
| H2508 | 8x8               | 244x244         | 2                   | Ear Type 2    | 1298x165x85              | 13          |
| H2512 | 12x12             | 366x366         | 2                   | Ear Type 2    | 1905x165x85              | 16          |



**FOLD-DOWN AND BRING UP**  
Fold Away Compact is the evolution of the standard version. A locking mechanism allows the frame to be folded even smaller for even easier transportation.



## LIGHTWEIGHT FRAME

The Avenger Fast-Loc Frame kit is lightweight and quick to set up. The square section aluminum tubes slide and lock together to provide a strong frame which supports lighting control textiles of (6'x6' in size).

| Code | Frame Size [feet] | Frame Size [cm] | N. of tubes per side | Tube Length x Thickness mm | Tube Connection | Frame Support | Weight [kg] | Optional Frame Bag |
|------|-------------------|-----------------|----------------------|----------------------------|-----------------|---------------|-------------|--------------------|
| H660 | 6x6               | 183x183         | 1                    | 1205x1.4                   | insert          | Stud Type x2  | 6,9         | H6BAG              |



Stud Type (code RH01051).

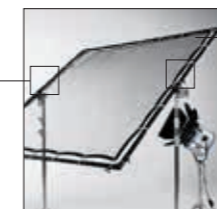

The Manfrotto Butterfly Frames uses two methods of support. Ear and Stud as illustrated.



Ear Type (code RH01016).



Insert tube connection.

## MODULAR FRAMES

Heavy Duty 3mm square section tubes-slot and pin-lock together, rapidly providing a stable frame for lighting control textiles. By reducing or adding tubes you can create any frame size.

| Code   | Modular frame Size [feet] | Modular frame Size [cm] | N. of tubes per side | Tube Length x Thickness [mm] | Tube Connection | Frame Support | Weight [kg] | Optional Frame Bag |
|--------|---------------------------|-------------------------|----------------------|------------------------------|-----------------|---------------|-------------|--------------------|
| H600M  | 6x6                       | 183x183                 | 1                    | 1205x3                       | Pin             | Ear Type x2   | 11,4        | H6BAG              |
| H800M  | 8x8                       | 244x244                 | 2                    | 1205x3                       | Pin             | Ear Type x2   | 13,6        | H6BAG              |
| H1200M | 12x12                     | 366x366                 | 3                    | 1205x3                       | Pin             | Ear Type x2   | 19          | H6BAG              |
| H2000M | 20x20                     | 610x610                 | 5                    | 1205x3                       | Pin             | Ear Type x2   | 32,6        | H6BAG              |







When JOBY launched the GorillaPod® in 2006, they recognised that they had created a product that truly inspired user creativity. This concept was the cornerstone of their start-up story and it has taken them all over the world. While the market has changed in the years since those early days – from photography, to vlogging, and now into vertical storytelling, they have always sought new and better ways to capture content.

JOBY have always designed mounts, cases, lights, stands, and grips, with a user-centric approach – creating functional yet playful, innovative, and easy-to-use products.

Creating multi award-winning products and defining not only a new category but also a new generation of creators, the JOBY story is just beginning.

The materials used in JOBY products are some of the finest available – sourced from all over the world... medical-grade ABS plastic from Japan, TPE rubber from Germany, and custom-machined stainless steel parts are just a few examples of how JOBY hand-select the highest-quality materials to ensure that their products will stand up to the rigors of everyday use.

JOBY products are extensively tested in every condition they can possibly simulate, and once they have passed, their teams around the world continue the process with some real-world testing and feedback.

Today, JOBY continues to build their legacy, shaping the world of content creation day after day.

## Products:

Camera Solutions  
Action Camera Solutions  
Smartphone Solutions



# Camera Solutions



machined aluminum sockets

**3K PRO KIT**

### JB01566-BWW GORILLAPOD® 3K PRO KIT

Built for the Pro Content Creator. New optimized machined aluminum GorillaPod, precision engineered Ballhead with compact Arca-Swiss® compatible QR quick release plate. Perfectly pairs with the latest Mirrorless camera systems up to 6.6 lbs.

|                   |                                       |                                 |
|-------------------|---------------------------------------|---------------------------------|
| <b>Size</b>       | 3 x 2.1 x 11.8 in<br>77 x 53 x 300 mm |                                 |
| <b>Weight</b>     | 1 lb<br>463 g                         | <b>Capacity</b> 6.6 lbs<br>3 kg |
| <b>Connection</b> | 1/4"-20                               |                                 |
| <b>Order No.</b>  | JB01566                               |                                 |



machined aluminum sockets

**3K PRO RIG**

### JB01567-BWW GORILLAPOD® 3K PRO RIG

The premium partner for the Pro Content Creator. Add Flexible Arms to enable accessories like lights and mics to build a Vlogging toolkit for excellence.

|                   |  |                                 |
|-------------------|--|---------------------------------|
| <b>Size</b>       | 3.1 x 4.3 x 11.8 in<br>78 x 108 x 300 mm |                                 |
| <b>Weight</b>     | 1.2 lbs<br>580 g                         | <b>Capacity</b> 6.6 lbs<br>3 kg |
| <b>Connection</b> | 1/4"-20                                  |                                 |
| <b>Order No.</b>  | JB01567                                  |                                 |



machined aluminum sockets

**5K RIG**

### JB01522-BWW GORILLAPOD® RIG

The GorillaPod has arms! Flexible, portable and easy to use, the GorillaPod Rig is the essential tool for any content creator, vlogger or journalist creating pro-grade video.

|                   |  |                                |
|-------------------|--|--------------------------------|
| <b>Size</b>       | 3.1 x 4.7 x 13 in<br>80 x 120 x 330 mm |                                |
| <b>Weight</b>     | 1.85 lbs<br>840 g                      | <b>Capacity</b> 11 lbs<br>5 kg |
| <b>Connection</b> | 1/4"-20                                |                                |
| <b>Order No.</b>  | JB01522                                |                                |



machined aluminum sockets

**5K KIT**

### JB01508-BWW GORILLAPOD® 5K KIT

Built for the Pro. Machined aluminum GorillaPod, precision-engineered ballhead with Arca-Swiss® compatible quick-release plate. Supports professional cameras and devices weighing up to 11 lbs.

|                   |                                       |                                |
|-------------------|---------------------------------------|--------------------------------|
| <b>Size</b>       | 2.6 x 2.6 x 1.5 in<br>65 x 65 x 38 mm |                                |
| <b>Weight</b>     | 1.62 lbs<br>739 g                     | <b>Capacity</b> 11 lbs<br>5 kg |
| <b>Connection</b> | 1/4"-20                               |                                |
| <b>Order No.</b>  | JB01508                               |                                |



**3K KIT**

### JB01507-BWW GORILLAPOD® 3K KIT

Premium grade ABS GorillaPod, precision-engineered ballhead with quick release clip and bubble level. Supports DSLR/Mirrorless cameras and devices weighing up to 6.6 lbs.

|                   |                                       |                                 |
|-------------------|---------------------------------------|---------------------------------|
| <b>Size</b>       | 2.4 x 2.6 x 12 in<br>69 x 65 x 305 mm |                                 |
| <b>Weight</b>     | 0.86 lbs<br>393 g                     | <b>Capacity</b> 6.6 lbs<br>3 kg |
| <b>Connection</b> | 1/4"-20                               |                                 |
| <b>Order No.</b>  | JB01507                               |                                 |



**1K KIT**

### JB01503-BWW GORILLAPOD® 1K KIT

Premium grade ABS GorillaPod & compact ballhead support compact mirrorless cameras and devices weighing up to 2.2 lbs.

|                   |                                   |                                 |
|-------------------|-----------------------------------|---------------------------------|
| <b>Size</b>       | 1 x 1 x 10 in<br>25 x 25 x 256 mm |                                 |
| <b>Weight</b>     | 0.43 lbs<br>197 g                 | <b>Capacity</b> 2.2 lbs<br>1 kg |
| <b>Connection</b> | 1/4"-20                           |                                 |
| <b>Order No.</b>  | JB01503                           |                                 |



# Camera Solutions



JB01548-BWW  
**TELEPOD™ PRO KIT**

The TelePod PRO Kit works in 4 modes (handgrip, extended grip, elevated stand or table top tripod) for maximum versatility with 360 degree panning bed and 90-degree tilt for unlimited angles. 1 kg (2.2 lb) weight capacity is perfect for mirrorless, point and shoots, 360, action cams or video light. Expand your attachment options via 1/4"-20 mount plus included Pin Joint and Ball Head 1K. The removable Ball Head 1K can be used on your GorillaPod or with any 1/4"-20 tripod mount!

|                   |  |  |                 |                 |
|-------------------|--|--|-----------------|-----------------|
| <b>Size</b>       | 2.2 x 1.8 x 8.1 in<br>55 x 46 x 208 mm |  | <b>Capacity</b> | 2.2 lbs<br>1 kg |
| <b>Weight</b>     | 0.53 lbs<br>244 g                      |  | <b>Capacity</b> | 2.2 lbs<br>1 kg |
| <b>Connection</b> | 1/4"-20                                |  |                 |                 |
| <b>Order No.</b>  | JB01548                                |  |                 |                 |



JB01555-BWW  
**HANDYPOD™**

HandyPod is a mini tripod for content creators looking for a lightweight, portable, and easy-to-use support system. It helps you to flawlessly capture challenging video shots that are steady and smooth. The push-button mechanism enables to position and lock the ball head in one rapid, intuitive movement and to move it into portrait position. The rubber grip gives an ergonomic and secure handle of the camera while the rubber feet guarantees a stable and slip-free foundation on any surface.

|                   |  |  |                 |                 |
|-------------------|--|--|-----------------|-----------------|
| <b>Size</b>       | 1.7 x 2.1 x 7.4 in<br>42 x 53 x 190 mm |  | <b>Capacity</b> | 2.2 lbs<br>1 kg |
| <b>Weight</b>     | 0.4 lbs<br>185 g                       |  | <b>Capacity</b> | 2.2 lbs<br>1 kg |
| <b>Connection</b> | 1/4"-20                                |  |                 |                 |
| <b>Order No.</b>  | JB01555                                |  |                 |                 |

# Action Camera Solutions



JB01657-BWW  
**TELEPOD™ SPORT**

Our TelePod SPORT is perfect for creators looking to shoot securely on the go! It works in 4 modes so you never miss a shot: Handgrip, Extended Grip, Tabletop Tripod and Elevated Tripod. Super strength and long waterproof extension pole (up to 1200 mm/47 inches) make outdoor action scenes easy and effortless with an invisible footprint. The TelePod SPORT kit includes Extendable Pole, solid Tripod Base, wrist strap and Pin-Joint Mount.

|                   |   |  |                 |                  |
|-------------------|---|--|-----------------|------------------|
| <b>Size</b>       | 1.2 x 1.2 x 13.7 in<br>30 x 30 x 348 mm |  | <b>Capacity</b> | 1.1 lbs<br>0.5kg |
| <b>Weight</b>     | 1.16 lbs<br>530 g                       |  | <b>Capacity</b> | 1.1 lbs<br>0.5kg |
| <b>Connection</b> | 1/4"-20                                 |  |                 |                  |
| <b>Order No.</b>  | JB01657                                 |  |                 |                  |



JB01589-BWW  
**GORILLAPOD® ARM KIT PRO**

This kit is the PRO version of JOBY GorillaPod Arm kit. With its Aluminium Construction, it is the perfect tool to connect accessories to GorillaPod and other Rigs. It features a 3/8" adaptor and Spring Loaded Anti-Rotation Pins for secure mounting. Supply in a package of 2.

|                   |   |  |                 |                   |
|-------------------|---|--|-----------------|-------------------|
| <b>Size</b>       | 1.3 x 1.6 x 10.0 in<br>336 x 414 x 255 mm |  | <b>Capacity</b> | 1.1 lbs<br>0.5 kg |
| <b>Weight</b>     | 0.67 lbs<br>305 g                         |  | <b>Capacity</b> | 1.1 lbs<br>0.5 kg |
| <b>Connection</b> | 1/4"-20<br>3/8"                           |  |                 |                   |
| <b>Order No.</b>  | JB01589                                   |  |                 |                   |



JB01532-0WW  
**GORILLAPOD® ARM KIT**

Mount more accessories for better videos with these flexible arms and mounts.

|                   |                                      |  |                 |  |
|-------------------|--------------------------------------|--|-----------------|--|
| <b>Size</b>       | 1 x 1.8 x 6.9 in<br>26 x 45 x 175 mm |  | <b>Capacity</b> |  |
| <b>Weight</b>     | 0.18 lbs<br>85 g                     |  | <b>Capacity</b> |  |
| <b>Connection</b> | 1/4"-20                              |  |                 |  |
| <b>Order No.</b>  | JB01532                              |  |                 |  |



JB01523-BWW  
**GORILLAPOD® RIG UPGRADE**

Transform your GorillaPod 5K Kit or 3K Kit into a GorillaPod Rig. Mount lights, mics and additional devices to your DSLR or mirrorless set-up to bring your creativity to light.

|                   |   |  |                 |  |
|-------------------|---|--|-----------------|--|
| <b>Size</b>       | 3.1 x 5.9 x 5.9 in<br>80 x 150 x 150 mm |  | <b>Capacity</b> |  |
| <b>Weight</b>     | 0.35 lbs<br>160 g                       |  | <b>Capacity</b> |  |
| <b>Connection</b> | 1/4"-20                                 |  |                 |  |
| <b>Order No.</b>  | JB01523                                 |  |                 |  |



JB01300-BWW  
**GORILLAPOD® ACTION TRIPOD**

This GoPro/action video tripod opens up a new dimension of possibilities. The GorillaPod Action Tripod has a ball head, is versatile, flexible and lightweight allowing you to take your action videography to the limits of your imagination. Perfect for GoPro Hero 9 and Max.

|                   |   |  |                 |  |
|-------------------|---|--|-----------------|--|
| <b>Size</b>       | 2.2 x 2.2 x 10.2 in<br>55 x 55 x 257 mm |  | <b>Capacity</b> |  |
| <b>Weight</b>     | 0.42 lbs<br>191 g                       |  | <b>Capacity</b> |  |
| <b>Connection</b> | 1/4"-20                                 |  |                 |  |
| <b>Order No.</b>  | JB01300                                 |  |                 |  |



JB01329-BWW  
**SUCTION CUP & GORILLAPOD® ARM**

Full of versatility this GoPro/action video suction cup mount has the flexibility of a GorillaPod arm attached to an industrial suction cup. An easy to use twist and lock system attaches quickly to smooth clean surfaces. Strength and flexibility make this a go-to tool.

|                   |   |  |                 |  |
|-------------------|---|--|-----------------|--|
| <b>Size</b>       | 1.6 x 5.3 x 7.8 in<br>40 x 134 x 200 mm |  | <b>Capacity</b> |  |
| <b>Weight</b>     | 0.24 lbs<br>110 g                       |  | <b>Capacity</b> |  |
| <b>Connection</b> | 1/4"-20                                 |  |                 |  |
| <b>Order No.</b>  | JB01329                                 |  |                 |  |



JB01515-BWW  
**GRIP TIGHT™ ACTION KIT**

The GripTight Action Kit holds smartphones and action cameras on our GorillaPod 500 stand via an integrated pin-joint mount. Use mount and stand together or separately. Includes Bluetooth® Impulse remote!

|                   |  |  |                 |  |
|-------------------|--|--|-----------------|--|
| <b>Size</b>       | 1.9 x 2.7 x 9.4 in<br>49 x 68 x 240 mm |  | <b>Capacity</b> |  |
| <b>Weight</b>     | 0.27 lbs<br>124 g                      |  | <b>Capacity</b> |  |
| <b>Connection</b> | 1/4"-20                                |  |                 |  |
| <b>Order No.</b>  | JB01515                                |  |                 |  |



# Smartphone Solutions



**JB01533-BWW**  
**GORILLAPOD® MOBILE RIG**

The GorillaPod has arms! Create pro-grade videos, vlogs and YouTube® content with this smartphone rig designed for content creators. Flexible, portable and easy to use, the new GorillaPod Mobile Rig securely mounts your smartphone, lights and mics.

**Size** 3.1 x 4.7 x 13 in  
80 x 120 x 330 mm

**Weight** 0.79 lbs  
**Capacity** 2.2 lbs / 360 g

**Connection** 1/4"-20

**Order No.** JB01533



**JB01534-BWW**  
**GRIP TIGHT™ PRO TELEPOD™**

Meet the first telescoping tripod from the makers of GorillaPod. The latest addition to JOBY's line-up of pro content creation tools, this handheld tripod/vlogging stick works in 4 modes for maximum versatility. Includes Bluetooth® Impulse remote shutter & metal cold shoe mount for lights & mics.

**Size** 2.2 x 1.8 x 8.1 in  
55 x 46 x 208 mm

**Weight** 0.9 lbs / 359 g

**Connection** 1/4"-20

**Features** Bluetooth®  
iOS & Android

**Order No.** JB01534



**JB01501-BWW**  
**GRIP TIGHT™ PRO VIDEO GP STAND**

Expertly engineered for smartphone videography, our GripTight PRO Video GP Stand is the answer to all your mobile filming and live streaming needs! The flexibility of our iconic GorillaPod; design paired with the security of our locking PRO mount featuring fluid pan and tilt make this the ultimate GorillaPod for smooth, professional-grade mobile video.

**Size** 3.1 x 2 x 11.8 in  
80 x 50 x 300 mm

**Weight** 0.62 lbs / 282 g

**Connection** 1/4"-20

**Order No.** JB01501

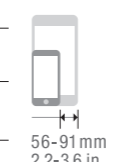

**JB01390-BWW**  
**GRIP TIGHT™ GORILLAPOD® STAND PRO (PHONE)**

The GripTight GorillaPod Stand PRO is a simple but effective GripTight PRO premium clamping mount paired with our classic GorillaPod 1K Stand. Locks down most phones with or without a case and built from durable ABS, TPE and Stainless Steel. This weapon of choice also delivers seamless Landscape to Portrait setups.

**Size** 2.2 x 3 x 12.2 in  
55 x 75 x 310 mm

**Weight** 0.53 lbs / 244 g

**Connection** 1/4"-20

**Order No.** JB01390

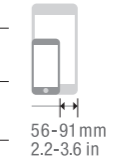

**JB01551-BWW**  
**GRIP TIGHT™ PRO 2 GORILLAPOD®**

The GripTight PRO 2 GorillaPod is our entry point into the big leagues of live streaming and active content creation. The adjustable, locking GripTight PRO 2 phone mount changes it up from portrait to landscape to match your output.

**Size** 5.3 x 6.6 x 13.5 in  
134 x 167 x 343 mm

**Weight** 0.62 lbs / 282 g

**Connection** 1/4"-20

**Order No.** JB01551





# Smartphone Solutions



JB01395-BWW  
**GRIP TIGHT™ GORILLAPOD® STAND PRO (TABLET)**

GripTight GorillaPod Stand PRO fits most tablets and offers a robust, locking and rotating solution for more optimal media viewing, photography, video capture, FaceTime, Skype, DIY projects; plus includes a flexible tripod for limitless setups.

|                   |                                       |                     |
|-------------------|---------------------------------------|---------------------|
| <b>Size</b>       | 2.1 x 3 x 11.6 in<br>54 x 76 x 297 mm |                     |
| <b>Weight</b>     | 0.63 lbs / 286 g                      |                     |
| <b>Connection</b> | 1/4"-20                               |                     |
| <b>Order No.</b>  | JB01395                               | 178-254mm<br>7-10in |



JB01394-BWW  
**GRIP TIGHT™ MOUNT PRO (TABLET)**

GripTight Mount PRO fits any smartphone or tablet and offers a robust, locking and rotating solution for more optimal setups for photos and videos.

|                   |                                      |                     |
|-------------------|--------------------------------------|---------------------|
| <b>Size</b>       | 2.1 x 3 x 5.3 in<br>53 x 76 x 136 mm |                     |
| <b>Weight</b>     | 0.33 lbs / 150 g                     |                     |
| <b>Connection</b> | 1/4"-20                              |                     |
| <b>Order No.</b>  | JB01394                              | 178-254mm<br>7-10in |



JB01389-BWW  
**GRIP TIGHT™ MOUNT PRO (BLACK)**

The GripTight™ Mount PRO is the professional solution for mounting practically any smartphone with or without case. Attach it to a GorillaPod®, TelePod™, HandyPod™, or any other support or stand with a 1/4" 20 screw, to offer a robust, locking and rotating solution for kick-ass Mobile Content Creation.

|                   |                                       |                       |
|-------------------|---------------------------------------|-----------------------|
| <b>Size</b>       | 2.1 x 3 x 26.7 in<br>53 x 76 x 680 mm |                       |
| <b>Weight</b>     | 0.23 lbs / 108 g                      |                       |
| <b>Connection</b> | 1/4"-20                               |                       |
| <b>Order No.</b>  | JB01389                               | 56-91mm<br>2.2-3.6 in |



JB01525-BWW  
**GRIP TIGHT™ PRO 2 MOUNT**

The next generation of our GripTight PRO, this pro-grade mount securely holds your smartphone in landscape or portrait mode for stable photos, videos and vlogs! Perfect for the latest Apple and Android phones.

|                   |  |                       |
|-------------------|--|-----------------------|
| <b>Size</b>       | 2.3 x 2.6 x 5.3 in<br>58 x 67 x 135 mm |                       |
| <b>Weight</b>     | 0.15 lbs / 69 g                        |                       |
| <b>Connection</b> | 1/4"-20                                |                       |
| <b>Order No.</b>  | JB01525                                | 56-91mm<br>2.2-3.6 in |



JB01517-OWW  
**GP MOBILE MINI**

Rubberized jaws securely hold phone while flexible leg joints ensure stability on any surface. Designed to hold any smartphone, regular or plus size, with or without a case.

|                   |  |                      |
|-------------------|--|----------------------|
| <b>Size</b>       | 1.4 x 1.4 x 5.1 in<br>35 x 35 x 130 mm |                      |
| <b>Weight</b>     | 12.6 oz / 359 g                        |                      |
| <b>Connection</b> | 1/4"-20                                |                      |
| <b>Order No.</b>  | JB01517                                | 60-84mm<br>2.4-3.3in |



JB01473-BWW  
**IMPULSE**

Upgrade your mobile photography with the new JOBY Impulse™. Take the ultimate selfies, include yourself in group photos and capture creative angles with this certified Bluetooth® remote camera control for iPhone & Android smartphones.

|                  |                                      |  |
|------------------|--------------------------------------|--|
| <b>Size</b>      | 1 x 1.3 x 0.39 in<br>26 x 32 x 10 mm |  |
| <b>Weight</b>    | 0.02 lbs / 10 g                      |  |
| <b>Order No.</b> | JB01473                              |  |

# Special Applications



Vitec Imaging Solutions' comprehensive brand portfolio has supported the ever-changing imaging needs of business organisations for over 50 years. Our business customers often have a very specific application in mind and therefore require specialist help and advice to select the right products. Our advisors will understand your needs

and your skill level and then advise on the correct product or combination of products to deliver the professional looking imaging content you require.

If a solution cannot be found within Vitec Imaging Solutions' existing product portfolio, we can also discuss customised or bespoke product solutions.

## Conferencing

### Corporate



**Our carefully selected solutions for corporate applications offer a range of different image capture packages for use with a smartphone, tablet or digital camera.**

Whether you are looking to capture moving images or stills for a sales presentation, an internal communication, record a conference or even create a small promotional sales video – Vitec Imaging Solutions has a solution to deliver professional results. Our solutions offer a mix of camera tripods with heads, audio capture, lighting and backgrounds that are ideal for whether you're shooting at your business location or outside on the move.

### Home & Education



**Our carefully selected solutions for education offer a range of different image capture packages for use with a smartphone, tablet or digital camera.**

Whether you are looking to capture moving image or stills for an online lesson, in the classroom or lecture theatre, a field trip or wanting to make a record of students' work – Vitec Imaging Solutions has a solution to deliver professional results. One of our solutions also includes an external mic for capturing professional audio to overcome typical sound issues when using only a camera.

### Medical



**Our carefully selected products for medical applications offer a range of support solutions plus image capture packages for use with a smartphone, laptop or digital camera.**

If you are looking to support and securely position a device in a particular location or you need to capture moving images or stills to record a medical condition, procedure or gather reference material – Vitec Imaging Solutions has a solution to deliver professional results. Our solutions offer a mix of adjustable arms, clamps, stands, brackets and camera/smartphone supports.

### Thermal Imaging



**Our carefully selected solutions for thermal imaging applications offer a range of different supports to help you securely position your device.**

Whether you are indoors or out on location we offer a range of support products that will enable you to securely position your device exactly where you need to. Our stands can all be adjusted to different heights, whilst our heads offer a range of movement for exact positioning. We also offer additional attachments to support associated devices such as laptops.

# Customised and Bespoke Products

If you cannot find a suitable product for your application in this catalogue, why not contact us to discuss a bespoke solution. We can offer various levels of service including personalization, Customisation, Co-operative product development and full bespoke design and build.

Our product specialist will contact with you and arrange a convenient time to understand your project in more detail. If you already know exactly what you need, we may immediately be able to match up one of our existing products

or a combination of products to meet your requirements. Alternatively, it might be that we need to customize an existing product or perhaps you are looking for an exclusive bespoke design. Our comprehensive portfolio of certified brands have been supporting the ever-changing needs of business organisations for over 50 years. With our team of specialist designers, a pioneering prototyping lab and extensive manufacturing facilities around the world, our experienced team are well positioned to offer a full design and manufacturing service to your business.

## Some of our business partners



### Personalisation

**SHURE**  
SOUND EXTRAORDINARY



### Customisation

**veo**



### Co-operative Product Development

SWAROVSKI  
OPTIK



### Bespoke Design and Build

**Leica**  
Geosystems



**ARRI**

**Canon**

**DPA**  
MICROPHONES

**FARO**

**FLIR**  
SYSTEMS

**GIFAS**  
ELECTRIC

**HEXAGON**

**LABINO**

**MIRION**  
TECHNOLOGIES

**MOVE 'N SEE**  
sport video tools

**PINEWOOD**  
— MBS —  
LIGHTING

**RTL**

**SENNHEISER**  
The Pursuit of Perfect Sound

**STEREOLABS**

**US**  
TACTICAL SUPPLY

**VAONIS**  
SHARE YOUR UNIVERSE





